



Vaccine Logistics Manual

FEDERAL DIRECTORATE OF IMMUNIZATION

Ministry of National Health Services, Regulations and
Coordination, Government of Pakistan



2023





Vaccine Logistics Manual

Federal Directorate of Immunization

Ministry of National Health Services, Regulations and Coordination

Government of Pakistan





Disclaimer

This publication was prepared by the U.S. Agency for International Development (USAID) funded, Global Health Supply Chain Program – Procurement and Supply Management (GHSC-PSM) project, managed by Chemonics International Inc. The authors' views expressed in this publication do not necessarily reflect the views of the USAID or the United States Government.

USAID Pakistan Supply Chain Cooperation Standards and Policies can be found at:
<https://v.lmis.gov.pk/docs/pakistan-supplychain-sops>

ISBN #: 978-627-7638-40-5



Contents

Acronyms	v
Acknowledgments	vii
Preface	ix
Introduction	1
1. Vaccines Logistics System	3
1.1 INTRODUCTION	4
1.2 PRODUCT SELECTION	6
1.3 IMMUNITY AND VACCINES	7
1.4 FORECASTING	21
1.5 PROCUREMENT	27
2. The Cold Chain System	33
2.1 INTRODUCTION	35
2.2 VACCINE STORAGE	36
2.3 COLD CHAIN EQUIPMENT AND ITS USES	43
2.4 MAINTENANCE OF COLD CHAIN EQUIPMENT	62
2.5 CONTROL AND MONITORING OF TEMPERATURES	65
2.6 THE COLD CHAIN DURING IMMUNIZATION SESSIONS	78
2.7 BREAKDOWNS AND EMERGENCIES	81
3. Non-Vaccine Items Storage and Disposal of Unusable	87
3.1 INJECTION EQUIPMENT	88
3.2 SAFETY BOX	89
3.3 STORAGE OF NON-VACCINE ITEMS	91
3.4 DISPOSAL OF UNUSABLES	94
4. Vaccines Logistics Management Information System	101
4.1 INTRODUCTION	101
4.2 TYPES OF RECORDS	102
4.3 STRUCTURE OF THE WEB-BASED LMIS, ITS PROCESS, AND USE	126
4.4 COMPUTER SYSTEMS	134
5. COVID Supply Chain Management	137
5.1 KEY COMPONENTS OF COVID SUPPLY CHAIN	137
5.1.1 PLANNING IS THE KEY TO SUCCESS	137
5.1.2 KEEP VACCINES AT THE CORRECT TEMPERATURE	138
5.1.3 TRACK AND TRACE	138
5.1.4 ENSURE PRODUCT INTEGRITY	138
5.1.5 MANAGE LAST-MILE DELIVERY, RETURNS AND POST-VACCINE TRACKING	138
5.2 COVID MANAGEMENT INFORMATION SYSTEM	139
6. Monitoring and Supervision of Logistics System	145
6.1 MONITORING AND SUPERVISION OF VACCINES LOGISTICS SYSTEM	145
6.2 CHECKLISTS FOR FIELD EVALUATION	146
References	153

APPENDIX	155
Appendix – A: Terms of Reference for the Condemnation Committee	157
Appendix – B: Logistics Management responsibilities	159
Appendix – C: Common Logistics Problems, Causes, and Examples of Possible Solutions.....	163
Appendix – D: Warehouse Staff Job Descriptions	165
DESIGNATION: PROCUREMENT OFFICER (BS-16).....	165
DESIGNATION: STORE KEEPER (BS-11)	166
DESIGNATION: REFRIGERATION ENGINEER (BS-17).....	167
DESIGNATION: ASSISTANT REFRIGERATION ENGINEER (BS-16).....	169
DESIGNATION: SUB ENGINEER (ELECTRICAL) (BS-14).....	169
DESIGNATION: HELPER (BS-02)	170
DESIGNATION: LABOR (BS-02)	171
Appendix – E: Staff Health and Safety	173
1. INTRODUCTION	173
2. COMPLIANCE STATEMENT	173
3. WORKPLACE VIOLENCE CLASSIFICATION.....	174
4. RESPONSIBILITY.....	175
5. REPORTING	176
6. COMMUNICATION.....	177
7. HAZARD ASSESSMENT	177
8. INCIDENT INVESTIGATION	178
9. HAZARD CORRECTION	178
10. TRAINING, INSTRUCTION, AND INFORMATION	178
11. INCIDENT RECORDKEEPING	179
12. WAREHOUSE STAFF HEALTH SAFETY AND SECURITY CHECKLIST.....	180
Appendix – F: Standard Operating Procedures.....	183
INTRODUCTION.....	183
ISO CERTIFICATION REQUIREMENTS AND PROCESSES	183
RECEIPT PROCEDURE	184
PROCEDURE FOR VACCINES PURCHASED FROM INTERNATIONAL RESOURCES	184
PRE-ALERT SHIPMENT INTIMATION.....	184
COLLECTION OF VACCINE FROM THE AIRPORT.....	185
SHIPMENT INSPECTION.....	185
RECEIVED SHIPMENT CHECKLIST	186
STOCK PLACEMENT	186
VACCINE INVENTORY MANAGEMENT.....	188
PROCEDURE	188
DRY STORE	189
SHIPMENT PRE-ALERT	189
COLLECT SHIPMENT FROM THE PORT OF ENTRY	190
SHIPMENT INSPECTION	190
RECEIVED SHIPMENT CHECKLIST	191
STOCK PLACEMENT	191

SYRINGES AND SAFETY BOXES.....	191
REFRIGERATORS, FREEZERS, VACCINE CARRIERS, AND COLD BOXES.....	192
STORAGE.....	192
COLD STORE	192
TEMPERATURE CHART.....	194
STORAGE OF SHIPMENT CHECKLIST	195
DRY STORE.....	196
ISSUE PROCEDURE.....	198
COLD STORE	198
PACKING VACCINES.....	199
PREPARE ICE PACKS/COOL WATER PACKS	199
PACKING VACCINES THAT ARE NOT DAMAGED BY FREEZING	199
PACKING FREEZE-SENSITIVE VACCINES USING CONDITIONED ICE PACKS	200
PACKING FREEZE-SENSITIVE VACCINES USING COOL WATER PACKS.....	200
PACKING DILUENTS	201
DRY STORE.....	203
DISPOSAL.....	205
UNUSABLE VACCINE.....	205
DAMAGED ANCILLARY ITEMS	206
Appendix – G: Warehouse Monitoring and Evaluation Checklist	207
WAREHOUSING AND INVENTORY MANAGEMENT CHECKLIST.....	207
WAREHOUSE SAFETY AND SECURITY CHECKLIST.....	211
COLD CHAIN MAINTENANCE AND MONITORING CHECKLIST	214
TRANSPORT CHECKLIST	218
Appendix – H:How to Use the ILR.....	221
Figures	
FIGURE 1. LOGISTICS CYCLE	5
FIGURE 2. HEAT SENSITIVITY OF VACCINES.....	10
FIGURE 3. INJECTION SITE AREA.....	17
FIGURE 4. TECHNIQUES FOR INTRADERMAL, SUBCUTANEOUS AND INTRAMUSCULAR INJECTIONS.....	18
FIGURE 5. INTRADERMAL INJECTION TECHNIQUE FOR BCG.....	19
FIGURE 6. TECHNIQUE FOR SUBCUTANEOUS INJECTION	19
FIGURE 7. TECHNIQUE FOR INTRAMUSCULAR INJECTION.....	19
FIGURE 8. PROCUREMENT CYCLE.....	29
FIGURE 9. COLD CHAIN SYSTEM.....	35
FIGURE 10. WHO/FDI SYMBOL FOR CFC-FREE COLD CHAIN EQUIPMENT	43
FIGURE 11. COLD BOX USED IN THE COLD CHAIN	45
FIGURE 12. HOW TO LOAD A COLD BOX	46
FIGURE 13. VACCINE CARRIERS	48
FIGURE 14. HOW TO LOAD A VACCINE CARRIER.....	48
FIGURE 15. HOW TO FILL AN ICEPACK.....	49
FIGURE 16. ARRANGING ICEPACK FOR FREEZING	50
FIGURE 17. REFRIGERATED VEHICLES	50
FIGURE 18. COLD ROOM OR FREEZER ROOM (PREFABRICATED MODULAR WALK-IN FOR STORAGE OF VACCINES)...	51
FIGURE 19. COLD ROOM 50 M ³ CAPACITY AT STORE.....	52
FIGURE 20. FREEZER ROOM 50 M ³ CAPACITY AT STORE.....	53

FIGURE 21. TOP-OPENING FREEZER.....	57
FIGURE 22. ICEPACK FREEZER.....	54
FIGURE 23. VOLTAGE REGULATOR.....	55
FIGURE 24. ICE-LINED REFRIGERATOR.....	58
FIGURE 25. SOLAR POWERED REFRIGERATOR.....	60
FIGURE 26. COMMON THERMOMETER TYPES.....	66
FIGURE 27. VACCINE COLD CHAIN MONITOR CARD.....	68
FIGURE 28. TEMPERATURE DATA LOGGER.....	71
FIGURE 29. VVM.....	72
FIGURE 30. VVM STAGES.....	72
FIGURE 31. HOW TO READ THE VVM.....	73
FIGURE 32. TETANUS TOXOID SHIPPING INDICATOR.....	75
FIGURE 33. FREEZE-WATCH INDICATORS (FREEZE-TAG).....	76
FIGURE 34. FROZEN TEST VIALS.....	77
FIGURE 35. VACCINE SHAKE TEST.....	77
FIGURE 36. FOAM PAD WITH VIALS IN TOP OF VACCINE CARRIER.....	77
FIGURE 37. DISPOSABLE SYRINGES AND NEEDLES.....	88
FIGURE 38. AUTO-DESTRUCT SYRINGE.....	89
FIGURE 39. SAFETY BOX.....	90
FIGURE 40. PALLET RACKING SYSTEM AT WAREHOUSE.....	91
FIGURE 41. PALLETS.....	92
FIGURE 42. TROLLEYS.....	93
FIGURE 43. LANDFILL DISPOSAL.....	97
FIGURE 44. INCINERATORS.....	98
FIGURE 45. SHARPS PIT.....	99
FIGURE 46. VACCINE SUPPLY CHAIN.....	103
FIGURE 47. KEY COMPONENTS OF COVID SUPPLY CHAIN.....	1037
FIGURE 48. FLOW CHART OF PROCESS FOR ISSUING VACCINES.....	203

Tables

TABLE 1. TARGET DISEASES AND VACCINES IN PAKISTAN.....	9
TABLE 2. SENSITIVITY OF VACCINES TO FREEZING.....	11
TABLE 3. TETANUS TOXOID IMMUNIZATION SCHEDULE FOR WOMEN OF CHILDBEARING AGE AND PREGNANT WOMEN.....	16
TABLE 4. DOSAGE AND ADMINISTRATION OF VACCINES (SUMMARY).....	17
TABLE 5. ACCEPTABLE WASTAGE FACTORS.....	24
TABLE 6. RECOMMENDED VACCINE STORAGE TEMPERATURE.....	36
TABLE 7. TIME-TEMPERATURE EXPOSURE OF CCM CARD.....	70
TABLE 8. TIMES RECORDED FOR A VVM ATTACHED TO A VIAL OF OPV.....	73
TABLE 9. VVM REACTION RATES BY CATEGORY OF HEAT STABILITY.....	74
TABLE 10. KEY LOGISTICS STAFF AT VARIOUS LEVELS.....	159
TABLE 11. RESPONSIBILITIES OF FEDERAL, PROVINCIAL, AND REGIONAL LOGISTICS OFFICER/STORE-IN-CHARGE AND DESIGNATED DISTRICT LOGISTICS OFFICERS.....	159
TABLE 12. RESPONSIBILITIES OF STORE KEEPER.....	161
TABLE 13. COMMON LOGISTICS PROBLEMS, CAUSES, AND EXAMPLES.....	163
TABLE 14. WAREHOUSE SAFETY AND SECURITY ACTIVITY CHECKLIST.....	180

Acronyms

AD syringe	Auto-disable syringe
AEFI	Adverse Event Following Immunization
AMC	Average monthly consumption
BCG	Bacillus Calmette-Guérin (vaccine against tuberculosis)
°C	Degree Celsius
CCEM	Cold chain equipment management
CCM	Cold Chain Monitor
CFC	Chlorofluorocarbon
EEFO	Early-expiry, first-out
EVM	Effective Vaccine Management
EPI	Expanded Program on Immunization
FEFO	First-to-expire, first-out
FIFO	First-in, first-out
FDI	Federal Directorate of Immunization
GDN	Good Delivery Note
GPS	Global positioning system
GRN	Good Receipt Note
Hep-B	Hepatitis B
ILR	Ice-lined refrigerator
IPV	Inactivated polio vaccine
LMIS	Logistics management information system
LQAS	Lot Quality Assurance Sampling
ml	Milliliter
mm	Millimeter
NID	National immunization day
NPM	National Program Manager
OPV	Oral polio vaccine
PCV10	Pneumococcal vaccine
PPRA	Public Procurement Regulatory Authority
ROL	Request order level
RV	Rotavirus
SAR	Supplies Arrival Report
SIA	Supplementary Immunization Activity
SK	Store keeper
SOP	Standard operating procedure
TT	Tetanus toxoid (vaccine)
UC	Union Council
UNICEF	United Nations Children's Fund



UPS	Uninterrupted power supply
VAR	Vaccine Arrival Report
VVM	Vaccine vial monitor
V	Volt
WHO	World Health Organization
WMS	Warehouse management system

Acknowledgments

The vaccine logistics manual is an important initiative to support the federal and provincial staff in quality assurance, monitoring, and supervision of logistics systems for optimizing inventory management. It will facilitate the staff to follow the defined standard operating procedures to receive and distribute vaccines. This manual will allow the relevant staff for efficient vaccine distribution across Pakistan and improve staff performance and productivity.

The completion of this manual has been possible through the significant support of USAID funded GHSC-PSM project. The FDI highly appreciates the valuable support extended by USAID/Pakistan towards sustainable immunization supply chain system strengthening in the country. We thank Mr. Bradley Cronk, Director Health Office, USAID/Pakistan for his leadership in successfully strengthening, rehabilitating, and upgrading the FDI Warehouse in Islamabad to improve warehouse management system as per the international standards.

We would like to thank Dr. Muhammad Tariq, Country Director USAID funded GHSC-PSM project for his leadership and the hard work of his committed team in creating the Vaccine Logistics Manual.



Dr. Muhammad Ahmad Kazi
Director General
Federal Directorate of Immunization (FDI), Islamabad



Preface

The aim of developing this manual is to assist federal and provincial government staff in optimizing vaccine inventory management in Pakistan. In addition to this, it will provide guidance on quality assurance, as well as enhance monitoring and supervision mechanisms. We strongly believe that this manual will become a standard reference document for the Federal Directorate of Immunization nationwide. The manual will play a crucial role in improving the vaccine logistics management system and properly organizing record keeping.

Furthermore, we are confident that relevant authorities in the FDI and provincial EPI programs will fully benefit from this manual, as it focuses on reducing stock outs and minimizing wastage at the EPI Centers. The implementation process of the given guidelines is anticipated as a significant enhancement in logistics management, cold chain maintenance, and field supervision and monitoring mechanism.

We would like to express our sincere gratitude to our colleagues and friends at USAID, both in Islamabad and Washington, who provided invaluable leadership support throughout this project. Special thanks to Mr. Bradley Cronk, Dr. Shabir Chandio, Mr. Khalid Mahmood, Mr. Sherif Mowafy, Mr. John Vivalo, Mr. Keith Hummel, and Mr. Ramy Guirguis for their contributions and dedication.

Together, we strive to improve vaccine logistics and contribute to a more efficient and effective healthcare service delivery system in Pakistan.



Dr. Muhammad Tariq

Country Director

USAID Global Health Supply Chain Program – Procurement and Supply Management

Introduction

The public sector in Pakistan is mainly involved in procurement, storage, and distribution of vaccines to the end-user. The following departments/programs at the federal- and provincial-levels are responsible for making the vaccines available at the last mile:

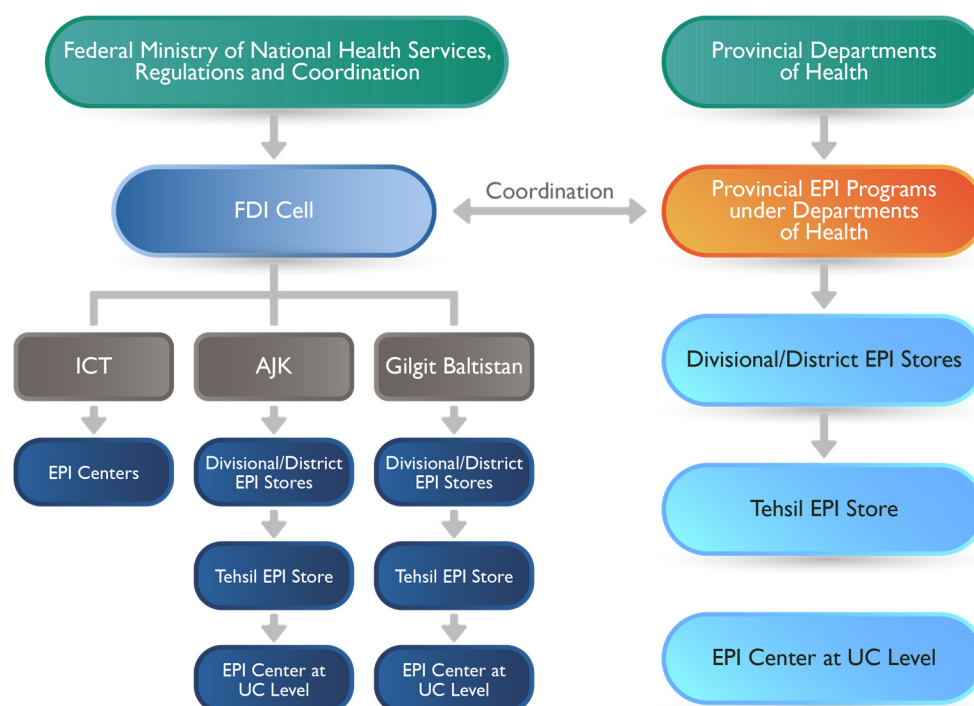

This manual includes operational guidelines developed to help the readers dealing with all parts of Vaccine logistics system—including the staff managing the information system and those managing and controlling the inventory systems. Guidelines for monitoring and assessing the functioning of the logistics system are included in the manual; these will help the staff that regularly monitor the system and the information will help senior managers in decision making to improve the system. At the beginning of each chapter, a table shows the various levels of staff involvement and its relevancy for each topic.

This manual provides basic information and techniques for managing vaccines, including diluents, syringes, and others in the cold chain system and for effectively using the vaccine logistics management information system (vLMIS). All efforts were made to keep the manual aligned with the Federal Directorate of Immunization (FDI) and provincial Expanded Program on Immunization (EPI) Policy and Strategic Guidelines, standard operating procedures, and Effective Vaccine Management guidelines from the United Nations Children’s Fund (UNICEF) and the World Health Organization (WHO).



1. Vaccines Logistics System

No	Description	National		Provincial/Regional		District	Tehsil	EPI Center
		Policy	Operations	Policy	Operations			
1.1	INTRODUCTION	✓	✓	✓	✓			
1.1.1	Logistics Management	✓	✓	✓	✓			
1.1.2	Components of a Logistics Management System	✓	✓	✓	✓			
1.1.3	Objectives of Efficient Logistics System	✓	✓	✓	✓			
1.2	PRODUCT SELECTION	✓	✓	✓	✓			
1.2.1	Purpose of Product Selection	✓	✓	✓	✓			
1.2.2	Process of Product Selection	✓	✓	✓	✓			
1.3	IMMUNITY AND VACCINES	✓	✓	✓	✓	✓	✓	✓
1.3.1	Immunity (Concept)	✓	✓	✓	✓	✓	✓	✓
1.3.2	Target diseases	✓	✓	✓	✓	✓	✓	✓
1.3.3	Types of vaccines	✓	✓	✓	✓	✓	✓	✓
1.3.4	Vaccine stability	✓	✓	✓	✓	✓	✓	✓
1.3.5	Correct administration of vaccines		✓		✓	✓	✓	✓
1.3.6	Policy on use of opened vials of vaccine	✓	✓	✓	✓	✓	✓	✓
1.4	FORECASTING		✓		✓			
1.4.1	Process of Forecasting		✓		✓			
1.4.2	Responsibilities of forecaster		✓		✓			
1.5	PROCUREMENT		✓		✓			
1.5.1	Principles of Procurement		✓		✓			
1.5.2	Objectives of Procurement		✓		✓			
1.5.3	General Procurement Process		✓		✓			

1.1 Introduction

Vaccines cannot reach the end-user without a reliable logistics management and cold chain system. Like any other system, the logistics management system has certain parameters on which it works. It refers to the specific functions that each responsible functionary must carry out. These functions include selecting products, forecasting demand, procuring, ordering, storing in optimal conditions, and delivering from one level to the next, until the vaccines reach the end-user (see Figure 1).

The logistics system includes all the activities that take place between the manufacturer and the point at which products are delivered to the end user.

1.1.1 Logistics Management

Efficient logistics management plays a pivotal role in the success of any program, project, or organization. All the activities of the logistics system are interlinked; therefore, if one activity is completed, the other activities are directly affected. If all the activities are not well managed and coordinated, the result is stockouts or overstocks and the efficacy of the vaccines is compromised.

An organization estimates its supply needs for the target population, identifies source(s) of supply; and then plans how to manage warehousing, quality assurance, transportation, and distribution to the end-users.

1.1.2 Components of a Logistics Management System

- Use (serving consumer)
- Selection of products to be used in the program
- Forecasting quantities to be procured
- Procurement
- Receiving items from suppliers, warehousing, and inventory management
- Distribution and transportation to lower levels
- Logistics management information system
- Quality assurance
- Monitoring and evaluation
- Policy adaptation

Figure 1. Logistics Cycle

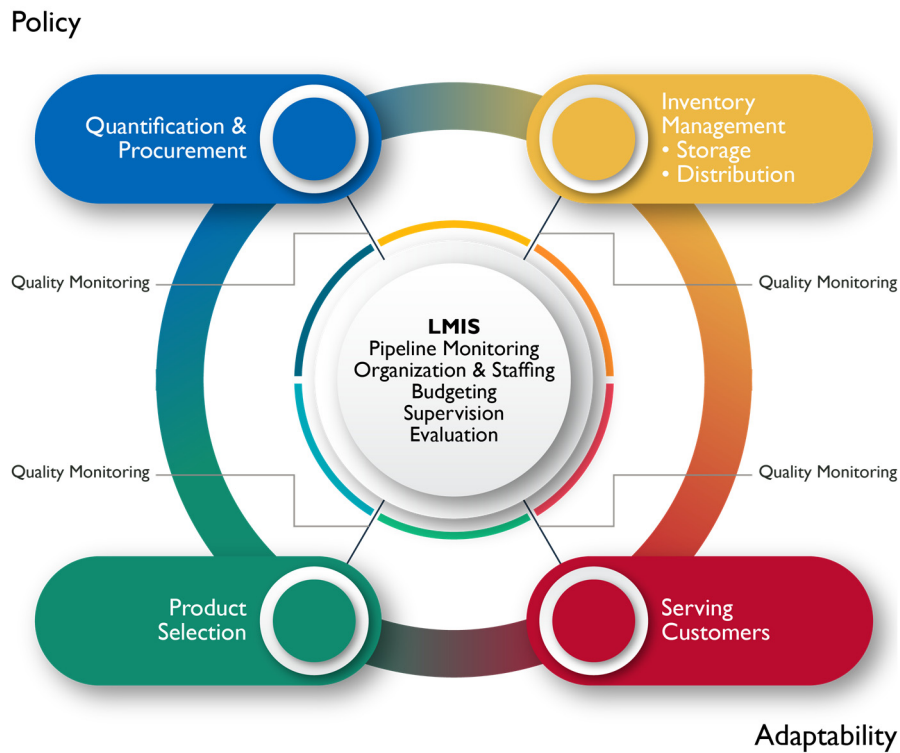

1.1.3 Objectives of an Efficient Logistics System

The primary objective of a good logistics system is to procure, store, and supply the right quantities of goods to meet consumer demand at all levels of the program. The Six Rights is a commonly used term to describe the objectives of an efficient logistics system:



These “Rights” should be seen from the perspective of the end-user.

The logistics system should ensure that they receive the care and vaccines they need. The Rights here refer to an efficient system in which the appropriate supplies are procured in the correct quantities, while minimizing the distribution cost.

Maintaining the balance between maximizing services and minimizing the costs of the system is a continuous challenge for health program managers. Investing in effective and efficient supply chains can maximize the use of resources; reduce wastage; improve the quality of services; and, ultimately, ensure product availability to meet the consumer's need. It is also the basis for advocating to mobilize more resources.

Right materials: Required vaccines, diluents, syringes, etc.

Right quantities: Requisite amounts of vaccines, diluents, syringes, etc., to meet the targets.

Right quality: Within the expiry date, useable vaccine vial monitor (VVM), no frozen freeze-sensitive vaccines, with proper and dry wrapper.

Right place: As determined in the micro plan, at an acceptable site that is accessible to all beneficiaries.

Right time: Ensure availability of vaccine for the end-user, when required.

Right cost: Quality products at a competitive price; reduced distribution and storage costs to maintain the cold chain.

To reach the end result of all the Six Rights, careful, stringent planning and execution is required—from the place and time of procuring and ordering commodities, to storing and stocking, to the final distribution and use by the end-user.

1.2 Product Selection

Product selection immediately follows serving customers in the logistics cycle, based on the customers' needs and the immunization program. Therefore, the success of any project depends on the accurate selection process for the required items and services. In most of the countries, vaccines are part of the Essential Medicines List. In a vaccines logistics system, product selection may be the responsibility of a committee or any other government-appointed group, based on recommendations from the WHO and UNICEF. In Pakistan, the National Vaccine Management Committee is responsible for product selection.

1.2.1 Purpose of Product Selection

Selection means choosing item(s) or services from the local or international market and from the available selection that have the highest possible quality and cost-effective items and/or services.

Objectives of the product selection are—

- To achieve the desired targets or goals set by the organization/program
- To stay focused to ensure that the logistics system can be managed effectively
- To utilize the resources efficiently
- To enable the management to make decisions about timely procurement
- To meet international health standards approved by WHO

1.2.2 Process of Product Selection

Before selecting the required items, the procurement technical evaluation committee of the procuring agency should review and evaluate all the available information before reaching a final decision.

The following must be considered:

- Obtain detailed specifications for the selected item/services.
- Conduct a preliminary market survey (national/international).
- Track the record or performance history of the manufacturer or supplier of the items or services to be obtained:
 - a) WHO-approved/prequalified
 - b) Quality, efficacy, and effectiveness of the product
 - c) Cost effective.

An organization's policy usually determines the quantities and types of vaccines, diluents, syringes, etc., that are to be procured. Product selection decisions frequently require the policymaker's input, which lessens the responsibility of the managers and staff for the actual product selection. However, managers and staff should share any information they have about local and regional preferences with the policymakers so that it can be considered when the final product selection is made.

1.3 Immunity and Vaccines

1.3.1 Immunity (Concept)

Whenever a person has an infection, the body starts developing antibodies to the virus or bacteria. These antibodies kill the microorganisms and, afterward, remain in the body to prevent a recurrence of the illness. For example, if someone had measles once in their lifetime, they will more than likely never contract this disease again, because the body has acquired immunity to measles.

During the first months of life, an infant is protected against many infections by antibodies acquired from the mother before their birth. The infant will retain these maternal antibodies for several months; but, usually, by the time the child reaches 1 year of age, these antibodies are no longer effective. The infant begins to develop its own antibodies, either after contact with a virus or bacteria, or after being immunized.

A vaccine (WHOa 2021) is a biological preparation that improves immunity to a particular disease. It typically has an agent that resembles a disease-causing microorganism and is often made from weakened or killed forms of the microbe, its toxins, or one of its surface proteins.

The agent stimulates the body's immune system to recognize the agent as foreign body, to destroy it, and to remember it; later, the immune system can more easily recognize and destroy any of these microorganisms that it encounters.

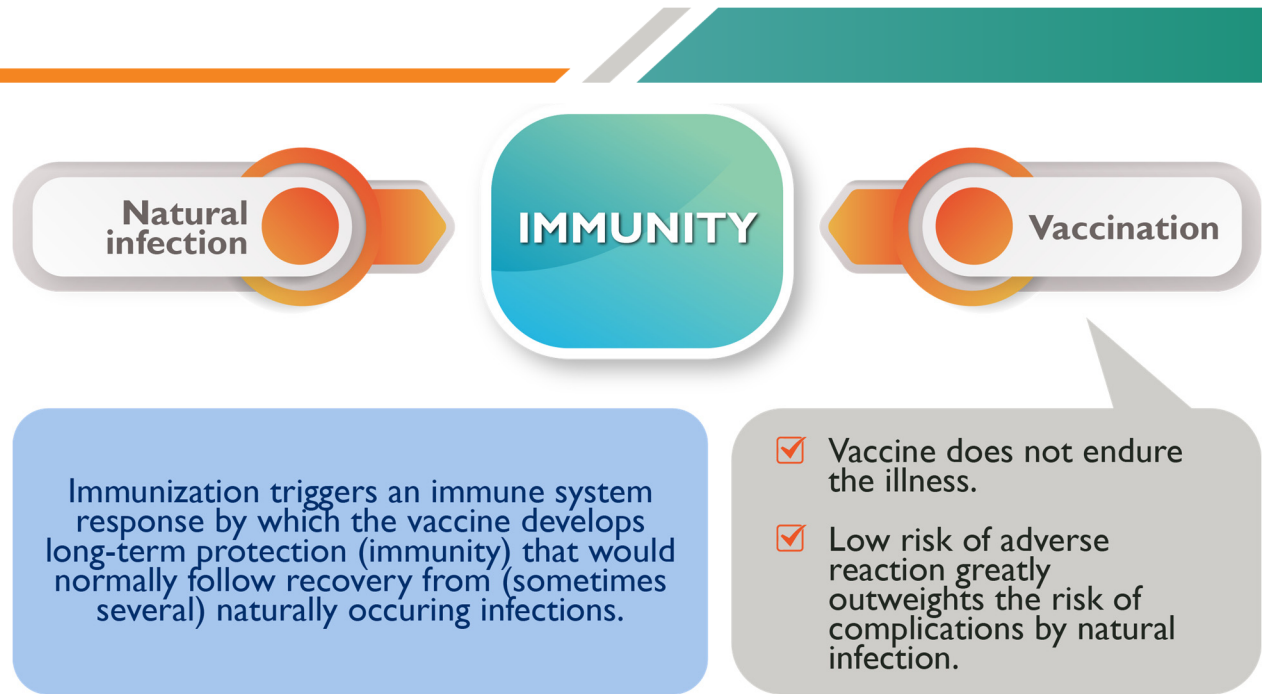

1.3.2 Target diseases

Many infectious diseases can result in the death or disability of infants and young children. These diseases have one thing in common—almost all can be prevented with immunizations which is the administration of a vaccine, produced from an attenuated, inactivated, or killed form of the virus or bacteria. A vaccine can be injected or given orally. It will provoke the development of antibodies in the infant, who acquires immunity without suffering from the disease.

The EPI is a global initiative of WHO, whose objective is to immunize all children worldwide against the most serious vaccine-preventable diseases (see table 1) (GOP 2022). WHO is joined by many other national- and international agencies in this effort; already a great deal of progress has been made to ensure that all the world's children are protected against these target childhood diseases. Most national health authorities also have their own programs of immunization for infants and young children; many include the WHO-target diseases, sometimes with other diseases, as their national program objectives.

Table 1. Target Diseases and Vaccines in Pakistan

No	Target Disease	Cause of Infection	Vaccine	Doses	Age of Administration
1	Tuberculosis	Bacteria	BCG	1	Soon after birth
2	Hepatitis B	Virus	Hep-B	1	Soon after birth*
3	Poliomyelitis	Virus	bOPV (Bivalent Oral Polio Vaccine)	4	0 – Soon after birth 1 st – 6 weeks 2 nd – 10 weeks 3 rd – 14 weeks
			IPV	2	1 st – 14 weeks 2 nd – 09 Months
4	Diphtheria	Bacteria	Pentavalent-1 (DPT + Hep-B + Hib)	3	1 st – 6 weeks 2 nd – 10 weeks 3 rd – 14 weeks
5	Tetanus	Bacteria			
6	Pertussis (whooping cough)	Bacteria			
7	Hepatitis B	Virus			
8	Haemophilus influenzae type B	Bacteria			
9	Pneumonia and meningitis due to S. pneumonia	Bacteria	Pneumococcal conjugate vaccine (PCV-13)	3	1 st – 6 weeks 2 nd – 10 weeks 3 rd – 14 weeks
10	Diarrhea caused by Rota Virus	Virus	Rota virus vaccine	2	1 st – 6 weeks 2 nd – 10 weeks
11	Measles and Rubella	Virus	Measles and Rubella (MR-10) vaccine	2	1 st – 09 months 2 nd – 15 months
12	Typhoid Conjugate Vaccine	Bacteria	Typhoid Vaccine	1	09 months
13	Tetanus Diphtheria	Bacteria	Td	2 plus	(for pregnant women)
14	Tetanus Diphtheria	Bacteria	Td	3 doses	(for lactating mothers)

* WHO recommends (WHO 2022) that all infants receive their first dose of hepatitis B vaccine as soon as possible after birth, preferably within 24 hours (GOP 2022). Delivery of hepatitis B vaccine within 24 hours of birth should be a performance indicator for all immunization programs. The birth dose should be followed by two or three doses to complete the primary series.

**.

1.3.3 Types of vaccines

Vaccines are produced from the same microorganisms or toxins that cause the disease; but, in both cases, are modified to be harmless to humans. A vaccine typically contains a biological agent that resembles a disease-causing microorganism; it is often made from weakened or killed forms of the microbe, its toxins, or one of its surface proteins.

The type and main substances used for the production of vaccines are (USAID 2003)

- Live attenuated: Come from disease-causing live viruses or bacteria that have been weakened under laboratory conditions (e.g., weakened measles and polio viruses or tuberculosis bacteria).
- Inactivated: Produced by growing viruses or bacteria and then inactivating them with heat or chemicals. Because they are not alive, they cannot grow in a vaccinated individual and, therefore, cannot cause the disease (e.g., whole-cell pertussis and IPV).
- Fractional: Comprised of only part of a cell and are either protein- or polysaccharide-based. Examples of protein-based vaccines are inactivated toxins tetanus toxoid (TT) and diphtheria toxoid. Examples of polysaccharide-based vaccines are Hib and meningococcal vaccines.
- Recombinant vaccines: Produced by inserting genetic material from a disease-causing organism into a harmless cell that replicates the proteins of the disease-causing organism. The proteins are then purified and used as vaccine (e.g., recombinant DNA hepatitis B vaccine).

1.3.4 Vaccine stability and storage conditions

All vaccines are sensitive biological substances that progressively lose their potency (i.e., ability to give protection against disease). This loss is much faster when the vaccine is exposed to temperatures outside the recommended storage range (WHOd 2023). After vaccine potency is lost, returning the vaccine to the correct storage condition cannot restore it. Any loss of potency is permanent and irreversible. Thus, to ensure that full vaccine potency is retained up to the administration, storing the vaccines at the correct recommended temperature conditions is vitally important. Although all vaccines are heat-sensitive, some are far more sensitive than others; the vaccines can be stored in order of decreasing sensitivity to heat (see Figure 2).

Figure 2. Heat Sensitivity of Vaccines

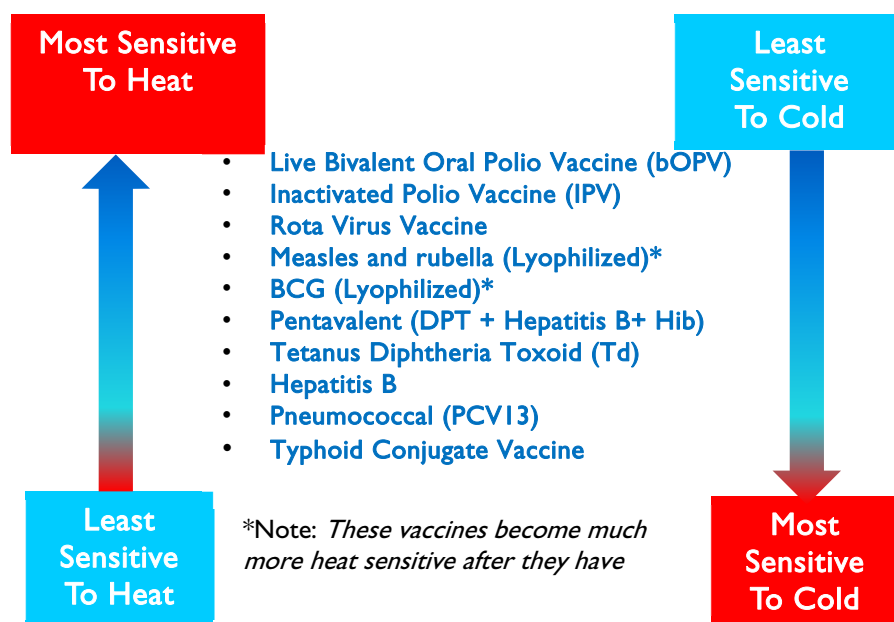

Some vaccines are also highly sensitive to extreme cold; if frozen, they will lose all their potency, although others can sustain freezing without any damage (see Table 2).

Therefore, it is vitally important to know the correct storage conditions for each vaccine, and to ensure that each is always kept at the recommended conditions.

Table 2. Sensitivity of Vaccines to Freezing

Vaccines Damaged by Freezing	Vaccines Unaffected by Freezing
Pentavalent	BCG (lyophilized or not constituted)
IPV	OPV
Td	Measles and rubella (lyophilized or not constituted)
PCV13	
TCV	
Rota Virus Vaccine	
Hepatitis-B	

Note: Vaccines freeze at temperatures just below zero.

- Bacillus Calmette-Guérin (BCG) and measles and rubella vaccines must not be frozen after reconstitution.
- Never freeze any diluent for any vaccine.

In addition to being temperature-sensitive, some vaccines are very sensitive to light and will lose their potency if exposed to ultraviolet light. BCG and measles and rubella vaccines are light-sensitive and must always be protected from sunlight and fluorescent (neon) light. Some manufacturers provide these vaccines in vials made of a darker glass. As with loss of potency due to heat, any loss of potency due to light is also permanent and irreversible.

Note that all losses of potency are cumulative; each time a vaccine is exposed to inappropriate temperature or sunlight, its potency will decrease. Because the vaccine may have been exposed previously, any new exposure—however small—will increase the damage to the vaccine. Ultimately, due to cumulative damage, the vaccine may be completely destroyed, with all its potency lost.

Note also that even when stored at the correct temperature, vaccines do not retain potency forever. Therefore, the expiry date marked on a vial or packet of vaccine must be strictly observed even when the correct storage temperature has always been maintained.

1.3.5 Correct administration of vaccines

The WHO manual—Immunization in Practice—gives detailed instructions on the correct procedures for administering each vaccine.

1.3.5.1 Bacillus Calmette-Guérin vaccine

BCG is a live bacterial vaccine. It is a freeze-dried powder that must be reconstituted before use. Only use the diluent from the manufacturer of the vaccine in use to reconstitute the vaccine. Diluent must be kept for 24 hours at 2–8° before reconstituting. Administer by intradermal injection. The dry frozen vaccine retains potency for a long time if stored under frozen conditions; however, because it is readily destroyed by sunlight, it is packaged in dark brown glass ampoules, which reduces the light penetration.

Administration:	Vaccine is given by intra-dermal injection, preferably on the deltoid region of the right arm.
Dose needed:	One dose at birth to complete the primary immunization.
Storage:	2° to 8°C (at all levels of the cold chain).
Type of VVM:	VVM14.

The vaccine is not damaged by freezing and can be frozen, thawed, and refrozen, without damage. The diluent however, must never be frozen. After reconstitution, the vaccine rapidly loses potency and must be used within six hours; the remaining vaccine must be discarded at the end of six hours. This is very important because the vaccine does not contain a preservative to prevent contamination.

IMPORTANT!

- Measles and rubella and BCG vaccines must only be reconstituted with the diluent provided by the manufacturer of the vaccine in use. Never use other diluents.
- Diluents must be cold, between 2° and 8°C, before being mixed with the vaccine.
- When reconstituted, the vaccine must be used within six hours, and any remainder discarded.

1.3.5.2 Oral polio vaccine

The vaccine most commonly used is made from a live attenuated polio virus, which is administered orally, as a liquid. The vaccine is quickly destroyed by temperatures above +8°C; of the commonly used childhood vaccines, oral polio vaccine (OPV) is the most sensitive to heat. It is not damaged by freezing, and can be safely frozen, thawed, and refrozen many times without damage.

Administration:	Give the vaccine orally (never by injection).
Doses needed:	Four doses to complete primary immunization (before 1 year) (see table 1).
Storage:	-15° to -25°C (federal- and provincial-levels); 2° to 8°C (district- and health facility-levels)
Type of VVM:	VVM2.



1.3.5.3 IPV

IPV comprises inactivated (killed) wild-type poliovirus strains of all three poliovirus types. Because IPV is an inactivated vaccine and not a live attenuated vaccine, it carries no risk of vaccine-associated polio paralysis (WHOc 2023). IPV is less sensitive to heat, compared to OPV; however, it is damaged by freezing.

Administration:	Vaccine is given by intramuscular injection in the anterolateral aspect of the left thigh.
Doses needed:	One dose in the introductory phase at week 14 (see table 1).
Storage:	2° to 8°C
Type of VVM:	None, VVM7.



1.3.5.4 Pentavalent vaccine

Pentavalent vaccine contains five antigens: (1) diphtheria toxoid, (2) inactivated pertussis vaccine, (3) TT (previously known as DPT or triple vaccine), (4) haemophilus influenzae type B (also known as Hib vaccine), and (5) hepatitis B vaccine. A liquid vaccine, it is administered by deep intramuscular injection. The vaccine is heat-sensitive, although less than OPV and measles and rubella; it is destroyed by freezing. The storage temperatures should never be less than 2°C.

Administration:	Vaccine is given by deep intramuscular injection in the anterolateral aspect of the right thigh. Never give intramuscular injections in an infant's buttocks.
Doses needed:	Three doses of 0.5 milliliter (ml) each, with one-month interval, or with routine pneumococcal vaccine to complete primary immunization (see table 1).
Storage:	2° to 8°C (at all levels of the cold chain).
Type of VVM:	VVM14.



1.3.5.5 Pneumococcal vaccine

Pneumococcal vaccine (PCV13), a liquid vaccine, is administered by deep intramuscular injection. The vial contains two doses. The vaccine is heat-sensitive, although less than OPV and measles and rubella, but it is destroyed by freezing. The storage temperatures should never be less than 2°C.

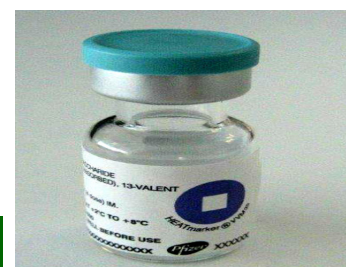

Administration:	Vaccine is given by deep intramuscular injection in the anterolateral aspect of the left thigh; never give intramuscular injections in an infant's buttocks.
Doses needed:	Three doses of 0.5 ml, each, with one-month interval; or with routine pentavalent vaccine to complete primary immunization (see table 1).
Storage:	2° to 8°C (at all levels of the cold chain).
Type of VVM:	VVM30.

1.3.5.6 Rotavirus vaccine

Currently, the available vaccines are live, oral, attenuated rotavirus (RV) strains of human and/or animal origin; it replicates in the human intestine. Two oral rotavirus vaccines are marketed internationally: the monovalent (RV1) and the pentavalent (RV5).



Administration:	Vaccine is given orally (never given by injection).
Doses needed:	Administer RV1 orally in a two-dose schedule; administer RV5 orally in a three-dose schedule, with an interval of at least four weeks between doses with routine pentavalent vaccine to complete primary immunization.
Storage:	2° to 8°C (at all levels of the cold chain).
Type of VVM:	VVM7.

13.5.7 Typhoid conjugate vaccine

A typhoid conjugate vaccine (TCV) is a preparation of *Salmonella Typhi* or *Citrobacter freundii* s.l. Vi polysaccharide covalently linked to a carrier protein. It is presented as a sterile aqueous suspension or as freeze-dried material. Once opened, store vaccine vial between 2 °C and 8 °C for 6 hours maximum otherwise typhoid vaccine loses effectiveness.



Administration:	Vaccine is given by injection at anterolateral part of the thigh in children
Doses needed:	One dose to complete primary immunization (see table 1).
Storage conditions:	2° to 8°C (at all levels).
Type of VVM:	VVM 30.

1.3.5.8 Measles and rubella vaccine

Measles and rubella vaccine is made from a live attenuated measles and rubella virus. It is a freeze-dried powder that must be reconstituted before use. Only use the diluent from the manufacturer of the vaccine to reconstitute the vaccine; administer the vaccine by subcutaneous injection. The dry frozen vaccine remains potent for a long time if stored under frozen conditions. Like OPV, it can be safely frozen, thawed, and refrozen many times without damage. However, never freeze the diluent.



After being reconstituted, the vaccine becomes very sensitive to heat, with a rapid loss of potency—it must be used within six hours; the remaining vaccine must be discarded after six hours. This is also very important because this vaccine does not contain a preservative to prevent contamination. Diluent must be kept for 24 hours at 2–8 degrees C before reconstitution; it must be from the same manufacturer.

Administration:	Vaccine is given by subcutaneous injection at anterolateral aspect of the left arm.
Doses needed:	Two doses to complete primary immunization (see table 1).
Storage conditions:	2° to 8°C (at all levels).
Type of VVM:	VVM 14.

1.3.5.9 Tetanus Diphtheria Toxoid Vaccine

All women giving birth and their newborn babies should be protected against tetanus to prevent maternal and neonatal tetanus. Women of childbearing age and pregnant women without previous Td vaccination should have a five-dose schedule (see table 3).

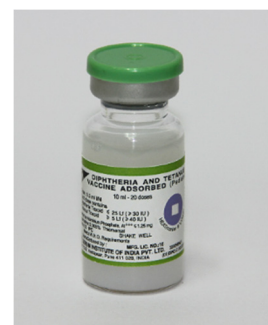

Administration:	Vaccine is given by intramuscular injection in deltoid muscle of left arm.
Doses needed:	(See tables 3 and 4).
Storage conditions:	2° to 8°C (at all levels of the cold chain).
Type of VVM:	VVM 14.

For more information about administering vaccines, see figures 3, 4, 5, 6, and 7.

Table 3. Tetanus Toxoid Immunization Schedule for Women of Childbearing Age and Pregnant Women

Tetanus Toxoid Vaccine	When to Give	Expected Duration of Protection
Td 1	At first contact, or as early as possible after 1st trimester of pregnancy	None
Td 2	At least 4 weeks after Td 1	1–3 years
Td 3	At least 6 months after Td 2 or during subsequent pregnancy	At least 5 years
Td 4	At least one year after Td 3 or during subsequent pregnancy	At least 10 years
Td C5	At least one year after Td 4 or during subsequent pregnancy	For all childbearing age and life long

Table 4. Dosage and Administration of Vaccines (summary)

Vaccine	No. of Doses for Primary Series	Administration	Site	Dose
BCG	1	Intradermal	Intradermal injection of the vaccine, preferably on the deltoid region of the left arm	0.05 ml
Hepatitis B	1	Deep intramuscular	Anterolateral aspect of the thigh or into the deltoid muscle for older children and adults	0.5 ml
OPV	4	Oral	Oral	2 drops
Pentavalent	3	Deep intramuscular	Anterolateral aspect of the right thigh	0.5 ml
Pneumococcal	3	Deep intramuscular	Anterolateral aspect of the left thigh	0.5 ml
Rota virus	2	Oral	Oral	2 drops
IPV	2	Deep intramuscular	Anterolateral aspect of the left thigh	0.5 ml
Measles and Rubella	2	Subcutaneous	Anterolateral aspect of the left arm	0.5 ml
Typhoid	1	Deep intramuscular	Anterolateral aspect of the left thigh	0.5ml
Td	2 plus	Deep intramuscular	Deltoid muscle of left arm	0.5 ml

Figure 3. Injection Site Area

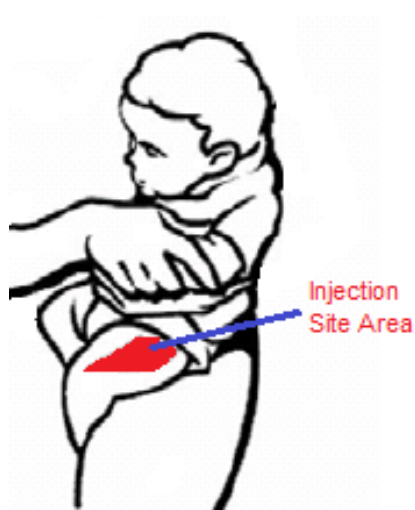

Intramuscular Injection - anterolateral aspect of thigh

Figure 4. Techniques for Intradermal, Subcutaneous and Intramuscular Injections

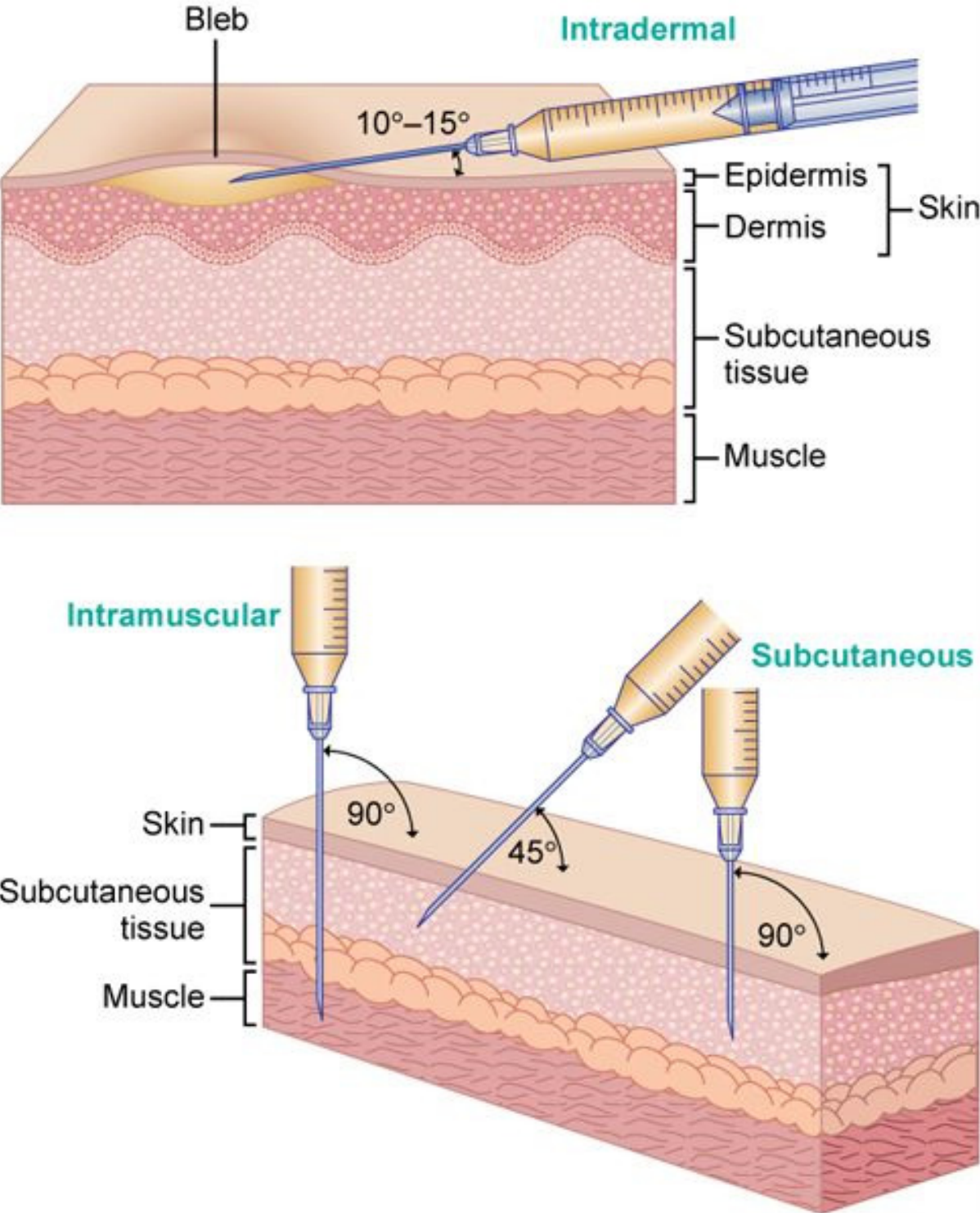

Figure 5. Intradermal Injection Technique for BCG



Figure 6. Technique for Subcutaneous Injection



Figure 7. Technique for Intramuscular Injection

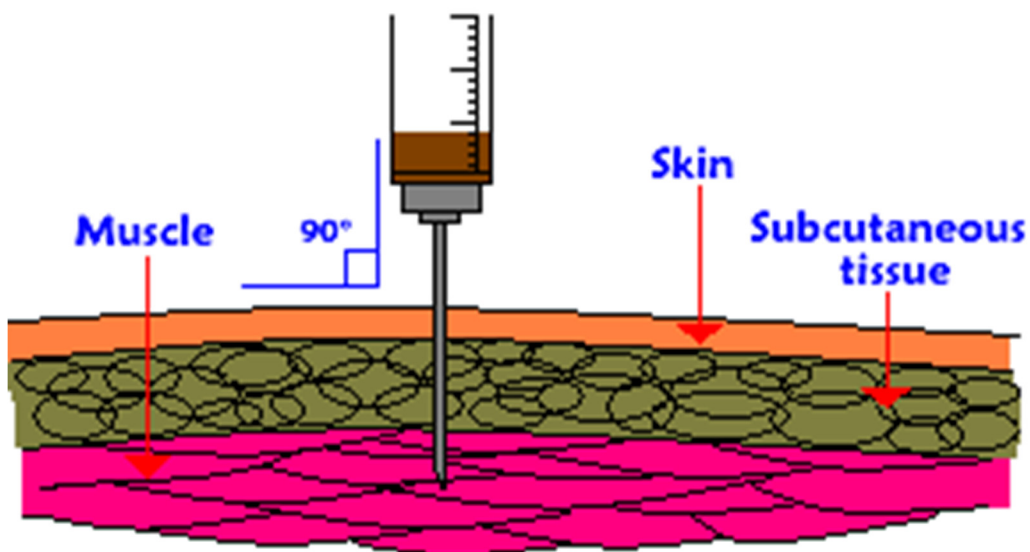

The vaccines may be obtained from a number of manufacturers and in different vial sizes (number of doses/vial).

IMPORTANT:

- All vaccines lose potency gradually, even at correct storage temperatures—observe expiry dates.
- All vaccines lose potency much faster when exposed to inappropriate temperatures (2° to 8°C).
- Any loss of vaccine potency is irreversible.
- Damage due to successive exposures to heat or light is cumulative.
- Pentavalent, PCV13, and Td are destroyed by freezing.
- BCG and measles and rubella vaccines are damaged by exposure to sunlight, as well as heat.

1.3.6 Policy on use of opened vials of vaccine

In Pakistan, vials with more than one dose are used for BCG, OPV, PCV13, measles and rubella, and Td.

The WHO recommended global policy on the use of opened vials for WHO-prequalified vaccine (WHO 2014) is as follows:

(1) Opened vials of OPV, IPV, hepatitis B, and Td vaccines at the FDI/EPI center can be used in subsequent immunization sessions, for a maximum of 28 days, if each of the following conditions are met:

- The expiry date has not passed
- The vaccines are stored under appropriate conditions (2° to 8°C)
- VVM has not reached the discard point
- The label is intact
- No sign of contamination
- Opened vials of vaccine taken out of the health facility for immunization activities, except OPV (e.g. outreach, national immunization days (NIDs)), are discarded at the end of the day.

(2) Opened vials of measles and rubella, Td and BCG vaccines must be discarded within six hours.

(3) An opened vial must be discarded immediately, if any of the following conditions apply:

- Sterile procedures have not been fully observed
- Even a suspicion that the opened vial has been contaminated
- Visible evidence of contamination, such as a change in appearance, floating particles, etc

(4) Store the partially used OPV, IPV, hepatitis B, PCV 13 and Td vials upright, in a separate box inside the ice-lined refrigerator (ILR)/refrigerator.

(5) In the next session, use the partially used vial first.

1.4 Forecasting

Forecasting performs a vital role in the efficient and effective functioning of logistics management. It is defined as the process of estimating the quantity of commodities needed to serve a given population for a specified period. Forecasting determines the quantities to be consumed, over the specified period of time, to meet the need of the intended beneficiaries.

This estimation helps avoid shortages (stockout), ensures credible service delivery, and prevents excess stock, which avoids waste—losses due to expiry or mismanagement of financial resources. Furthermore, efficient procurement, inventory management, and distribution primarily depend on realistic forecasting.

1.4.1 Process of Forecasting

More precise and realistic forecasting can be achieved by collecting, processing, and analyzing data that are relevant to future needs. Persons responsible for forecasting must have the information about future for a program—including new and revised health policies, opening new health facilities/EPI centers, introducing new vaccines, and expected increases in population/newborns.

The accuracy of the vaccine forecast is of significant to ensure uninterrupted vaccine availability. Overestimation of vaccine requirement results in expiries and increases costs, while underestimation leads to shortages that could be detrimental to the health of adults and children. In Pakistan, demographic data target population (live births for BCG, surviving infants for OPV, Pentavalent, PCV, Rotavirus, MR and Typhoid vaccine and pregnant women for TD vaccine) is most often used for forecasting. The number of children in each target group is estimated through 2023 census data. Projections based on estimated population growth are used to estimate the current size of the target group. In addition to the target population wastage multiplying factor, coverage, no of doses in vaccination schedule, closing balance and buffer stock as per National Policy are also considered as baseline parameters.

Another, more commonly used method for forecasting is to review the vaccine used during previous years, especially the last year. This method is known as logistics- or consumption-based forecast; it is usually the most accurate forecast. However, this method does not consider the vaccine wastage from poor storage, poor management, or expiries.

To prepare a reliable forecast, it is important to forecast based on more than one data type—demographic and logistics, in this case. The two forecasts can be compared and the more reliable one is chosen, based on robust assumptions. The WHO forecasting tool can also be used at <https://apps.who.int/iris/handle/10665/340747>

After the total order quantities are estimated, it is important to develop an accurate supply plan, after carefully considering the cold chain capacity. The supply planning keeps the stock at each level of the pipeline (central- to facility-level) between the maximum and minimum. The maximum and minimum for each level is based on the vaccine shelf life, vaccine storage capacity, and average monthly consumption.

Calculating How Much Vaccine to Order

To estimate the quantity of vaccine needed for primary immunization in any area (i.e., for a health facility, tehsil, district, or for the whole country), the following information will be needed:

- Number of children in the area to be immunized during the next 12 months
- Number of doses needed per child for each vaccine
- Estimated index of vaccine used (also called wastage factor) for each vaccine
- Number of vaccine deliveries planned for the next 12 months
- Amount of reserve vaccine stock (percentage) to be kept in the main store of the area
- Balance of vaccine stock remaining in the main store at the time of the estimate.

When estimating vaccine needs, to avoid some mistakes that commonly occur when estimates are prepared, remember the following points.

(1) Number of children to be immunized

For primary immunizations, this is the total number of children expected to be born in the next 12 months in the area: in the territory of the health facility, the tehsil, the district, or in the whole country. This projection can use the number of newborns from the previous year as a basis for the estimate.

All children must be included in the annual plan for primary immunization; include in this year's total any children from the previous year who did not yet receive their primary immunizations (backlog).

(2) Number of doses needed per child

This will be in accordance with the national immunization schedule (see table 1), and for the primary series (during the first two years of life) may include—

BCG	- 1 dose
OPV	- 4 doses
IPV	- 2 doses
Pentavalent	- 3 doses
Pneumococcal	- 3 doses
Rotavirus	- 2 doses
Measles and rubella	- 2 doses
Typhoid	- 1 dose

Similarly, for mass immunizations, outbreak control, or special campaigns keep calculations separate from estimates of primary immunization needs. Remember, a bigger vial size may sometimes be preferable for mass campaigns.

(3) Index of vaccine use (or wastage factor)

The actual wastage factor for each vaccine can be calculated from the records of numbers of immunizations given and amounts of vaccine used during a certain period: one month, three or six months, or a full year.

In general, more accurate figures are obtained if long, rather than short, periods of time are used in the calculation. The wastage factor is calculated separately for each vaccine, and for any period for which you have reliable records, using the formula:

$$\text{Index of vaccine use} = \frac{\text{Doses of vaccine used in a certain period}}{\text{(or wastage factor) Immunizations given during the same period}}$$

The index will probably be different for each vaccine; and, for each vaccine, it may vary over different periods of time (i.e., from one year to the next). It will also vary for the same vaccine based on the type of activity for example, routine sessions versus mass campaigns. It is useful to calculate an average figure for each vaccine, which can be calculated from the records over the last five years, for example. This figure can be updated each year by adding the new data on numbers of immunizations given and amounts of vaccine used during the last 12-month period.

Always use the data to calculate actual wastage rates for a particular situation, rather than using assumed values. If there is insufficient data to make the calculation, the information system is inadequate. Take steps as soon as possible to improve recording and reporting so that the necessary data can be collected and used for future calculations.

How to Calculate Vaccine Wastage

Each vial of OPV has 20 doses. To calculate wastage—

- Number of children vaccinated (X)
- Number of doses used (Y) to vaccinate (X) no. of children
- Number of doses wasted (Z) = Y - X

$$\text{Wastage} = \frac{Z \times 100}{Y}$$

Example:

- Number of children vaccinated: 60
- Number of vials used: 04
- Number of doses used is: $4 \times 20 = 80$
- Number of doses wasted $80 - 60 = 20$

$$\text{Wastage} = \frac{20 \times 100}{80} = 25\%$$

How to calculate the wastage multiplication factor (WMF)

- The vaccine wastage factor indicates how much additional vaccine should be ordered to allow for the given wastage rate (see table 5) (WHOc 2023).
- The vaccine wastage rate can vary greatly, according to several characteristics of the program: for example, session sizes, session plans, vial presentation, and supply management.

- The following formula shows the relationship between the vaccine wastage rate and the WMF (GOP 2022).

$$\text{WMF} = \frac{100}{100 - \text{wastage rate}}$$

Wastage rate	5%	10%	13%	15%	20%	25%	30%	35%	40%	45%	50%
WMF	1.05	1.11	1.15	1.18	1.25	1.33	1.43	1.54	1.67	1.82	2

Table 5. Acceptable Wastage Factors

Name of Vaccine	Acceptable Wastage Rate ¹	Wastage Factor
BCG	50%	2
Hepatitis B (birth dose)	10%	1.11
OPV	20%	1.25
IPV	20%	1.25
Pentavalent	5%	1.05
PCV 13	10%	1.11
Measles and rubella	20%	1.25
Typhoid	10%	1.11
Td	20%	1.25

(4) Number of Vaccine Deliveries Planned for the Next 12 Months

The immunization program should have a fixed schedule for deliveries of vaccines between each level of the cold chain and the next level. Usually, the central levels have longer delivery intervals, and the periphery has shorter intervals; but they should not exceed the maximum storage periods for each level described in Vaccine Storage, section 2.1. The choice of delivery interval is usually compromised, fewer deliveries mean lower shipping charges, but more vaccine must be sent in each delivery, and a larger and more expensive cold chain will be needed.

Many programs find that four deliveries per year at the national level, four deliveries per year at the provincial level, and 12 deliveries per year at the district- and health facility levels are the best balance. Using figures appropriate for the program, calculate the amount of vaccine to be sent in each delivery by dividing the annual needs by the number of vaccine deliveries planned during the year.

(5) Reserve vaccine stock to be kept in hand (in doses)

Vaccine storage points, at all levels of the cold chain, should always keep a reserve stock balance. This will allow for unexpected increases in vaccine use if, for example, there is an outbreak of disease, or the arrival of a planned vaccine delivery is late.

¹ National EPI Policy & Strategic Guidelines 2022

The amount of reserve needed at any level depends on its remoteness from the central store, the reliability of vaccine deliveries, or the capacity of equipment available.

Typically, the amount of reserve stock kept is 20–25 percent of the amount used during one delivery period. However, any amount is appropriate if, based on local experience, it ensures that you never completely run out of stock.

When the reserve stock level is determined for each storage point, this amount is called the minimum stock for the store. Stocks should never fall below this absolute minimum.

The maximum stock to be kept at any storage point should be the total vaccine needed, as calculated above, plus the amount determined as the reserve stock.

Provided the immunization program is running normally, the amount of stock at each storage point should always remain between these two levels, never more than the maximum and never less than the minimum. This would indicate a well-run store, with good stock control.

(6) Balance of vaccine stock remaining in the store (in doses)

All the calculations above are for determining vaccine needs; but usually, this is not the amount to be ordered or purchased. Now, the balance of vaccine stock remaining in the store must be checked, and this figure subtracted from the total calculated needs. If this last, but very important step, is not done, the result is often large overstocks accumulating, serious overcrowding of cold chain equipment, and expired vaccines.

(7) What vial sizes to order

The most useful size of vial to order (1-, 2-, 5-, 10-, or 20-dose, etc.) depends on the type of immunization being conducted—routine or mass campaign—the number of people to be served, and the number of health facilities to which vaccine must be sent. For example, 1,000 doses in 20-dose vials yields 50 vials for distribution, but 10-dose vials hold 100 vials for distribution. However, remember, smaller vial sizes are normally more expensive; therefore, a compromise may be needed. Moreover, with the limited number of vaccine manufacturers/suppliers, the choice of vial size may be limited.

IMPORTANT!

- Always subtract the stock balance remaining in the store from calculated total needs before placing the vaccine order.
- Always specify vial size required when ordering.
- And remember!
- All calculations and estimates must be in doses of vaccine. Do not confuse doses with numbers of vials and ampoules.

Forecasting the requirements for Td is more difficult than forecasting for childhood vaccines because the target population for Td is girls and women, who have approximately 30 years of eligibility—usually between ages 15 to 49 years.

Also, the intervals between each of the five doses vary. The previous year's Td usage will usually provide the best estimate of the current year's need, but always adjust that figure to the situation. For example, a Td campaign in high-risk areas may increase the demand for Td, while the demand will begin to decrease when several years of good Td coverage results in a build-up of protected women.

As discussed above, to calculate the amount of vaccine to order, managers need to know the size of the target population, number of doses in the primary series, expected coverage given the strategies to be used, supply interval, and wastage rate. The basic formula for calculating the order size for any vaccine is—

Target population × expected coverage × number of doses of the particular vaccine required × wastage factor

The calculation is then adjusted based on the amount of stock on hand and the reserve stock needed, as shown in the example below.

Example of Calculating Order Size for Pentavalent

Number of doses required

Target population = 1,000

Expected coverage = 70%

Number of doses per child required = 3

$1,000 \times 0.70 \times 3 = 2,100$ doses

Wastage rate

Wastage rate in this district is 25%.

Wastage factor or multiplier: $100 / (100 - 25) = 1.33$

Number of doses required per supply period

Supply period in district is every month (0.12 of a year).

$2,800 \times 0.12 = 336$ doses

Vaccine in stock

The amount of pentavalent that is needed in the district for this three-month supply period is 336 doses. If the district already has 200 doses in stock, the amount of vaccine to be ordered is 136 doses, not 336 doses. It is a common and costly mistake to order vaccine without adjusting for the amount in stock.

Reserve stock required

A percentage should be added for reserve stock. If 25% reserve stock is used, then an additional 84 doses are needed (25% of 336).

Amount to order: $136 + 84 = 220$ doses

The following are other factors that need to be considered when forecasting the requirements.

1.4.1.1 Delivery lead time

It is important to establish how long it takes for a supply to be received in the warehouse/store against a particular order or request. The time between order and receipt of supply is called lead time.

1.4.1.2 Request order level (reorder level)

The request order level (ROL) is the level of stock when new orders should be made. It is the quantity that is calculated to be used between the time of placing the order and the delivery of the new consignment. It should be updated at least twice a year, because consumption can vary, depending on seasonal changes.

1.4.1.3 Size of store

The warehouse capacity must be considered while forecasting. Serious problems might result if the volume of supplies ordered is too large compared to the volume that can be accommodated; it can lead to wastage of materials or cost for additional warehouse space. Shipments could be staggered and/or frequency of shipments could be scheduled if larger quantities are on order.

1.4.2 Responsibilities of forecaster

1.4.2.1 Forecast

The forecaster has to predict the amount of vaccine to be dispensed while considering the expected losses or damages in the logistics process.

1.4.2.2 Validate

Because many data sources and different forecasting methodologies are available, it is necessary to compare the results to analyze inconsistencies. If there are substantial differences, several reasons could cause the variations in the results. To ensure an accurate forecast, these reasons must be analyzed and validated, including input from many stakeholders.

1.4.2.3 Estimation of scarce commodities

Some products may not be available in the market in sufficient quantity; the forecaster must also look for multiple sources of supply, if possible, to meet the anticipated needs.

1.4.2.4 Monitor

The forecaster must check on the validity assumptions used for forecasting by comparing the forecast with the actual consumption for adjustment and correction. This would provide a basis for future forecasts.

1.5 Procurement

Procurement is a process that includes activities such as purchasing from a third party, as well as transporting and delivering to the given destination to meet the requirements of an organization. The general area of procurement provides opportunities to make practical improvements that will ensure cost effectiveness and promote product availability.

A proper vaccine procurement system requires collaboration across several parties to ensure that programmatic, funding, and quality control issues are adequately addressed.

1.5.1 Principles of Procurement

- The procurement shall be conducted in a fair and transparent manner
- The objective of procurement brings value for money
- The procurement process shall be efficient and economical

1.5.2 Objectives of Procurement

- **Quality:** The quality of vaccines procured cannot be compromised; the DRA must regulate their quality. Vaccine products of poor quality can destroy public confidence in an immunization program, placing even more lives at risk.
- **Reliability:** The vaccines should be sourced from a reputable supplier—preferably WHO-pre-qualified—that can demonstrate the reliable quality of its product and consistent adherence to good manufacturing practices.
- **Availability:** The vaccines should be sourced from supplier(s) that can ensure a consistent supply of high-quality product without risking supply interruption. Ruptures to stock are detrimental to national immunization programs and they diminish a program’s credibility.
- **Quantity:** This must be based on forecasting and the needs assessment of the organization.
- **Time:** Must be procured and delivered according to the established schedule.
- **Place:** Must be delivered to a specified location.
- **Price:** Best returns for each rupee spent in terms of quality, timeliness, reliability, after sales service, upgradeability, price, and source; including the combination of whole-life cost and quality to meet the procuring agency’s requirement.

1.5.3 General Procurement Process

A pre-requisite of procurement is to have a clear idea of what to procure. The selection and quantification of the commodities to be procured should be based on the needs and demands of the population. All procurements should be under Public Procurement Regulatory Authority (PPRA) rules. Figure 8 shows some essential activities of the procurement process.

Figure 8. Procurement Cycle

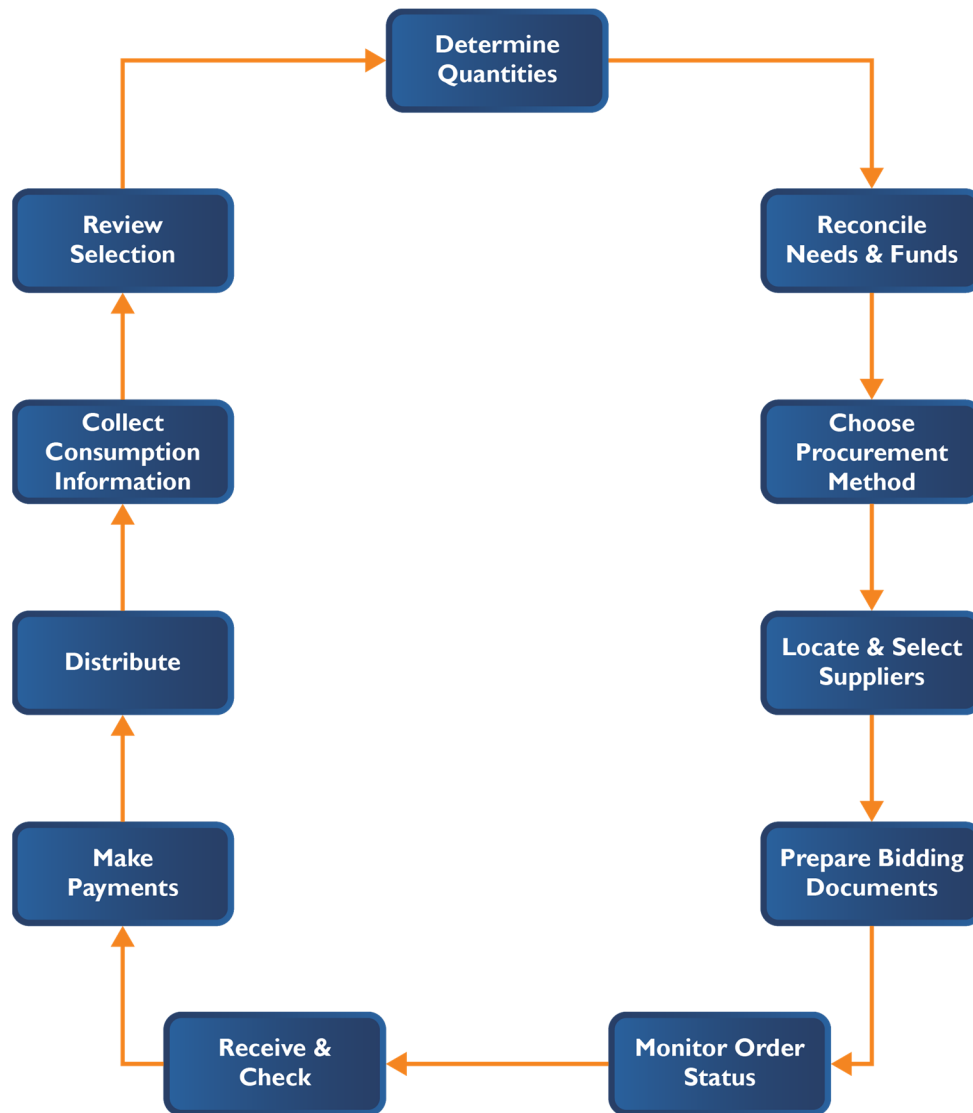

1.5.3.1 Forecasting

This is estimating the quantity of vaccines needed to serve a given population for a specified period of time. See section 1.4 on forecasting for more information on this process.

1.5.3.2 Preparation of specifications

This is complete description of the characteristics—technical and physical—of the vaccine to be procured is required. Specifications must be generic and must not include references to a brand name, catalog numbers, or similar classifications. Specifications can also include logistics parameters: delivery terms, payment terms, and others.

1.5.3.3 Preparation of bidding documents

Bidding documents must be prepared for the bidders and made available to them immediately after the publication of the invitation to bid. The essential components of the bidding documents or invitation to bid are—

- Instructions to bidders
- Form of bid
- Form of contract
- General and special conditions
- Performance criteria
- List of vaccines or cold chain equipment and quantities, including specifications related to packaging or labeling, etc.
- Delivery time or completion schedule
- Qualification criteria
- Bid evaluation criteria
- Format of all securities required
- Details of standards
- Mode of payment
- Tendering
- Any other details consistent with the rules

Steps for Procuring Vaccines at the National Level

- Pre-qualify the suppliers.
- Prepare bid documents.
- Advertise invitation for bids.
- Solicit and receive bids.
- Evaluate and compare bids.
- Select a supplier.
- Make an award.
- Write a contract.
- Make financial arrangements.
- Set up a contract monitoring system.
- Arrange for and monitor shipment.
- Accept delivery and clear customs

1.5.3.4 Public Announcement

A public announcement through the print and electronic media is required to invite bids for the purchase of vaccines and associated services.

1.5.3.5 Bidding and Quotation

Bidding and quotations have separate financial limits, as stated in the procurement rules.

1.5.3.6 Opening Bids

A designated committee will publically open the bids, in the presence of bidders or their authorized representatives, at a time and place announced prior to bidding.

1.5.3.7 Technical and financial evaluation

The bids will be evaluated, technically and financially, in accordance with the criteria set down in the bidding document.

1.5.3.8 Purchase/supply orders

Purchase/supply orders must clearly define the item name, quantity, approved rates, schedule of delivery, place of delivery, related terms and conditions, and mode of payment. Moreover, if necessary, the purchaser shall enter into a procurement contract with the supplier.

1.5.3.9 Quality and quantity assurance

On receipt of the consignment, each item must be physically counted and ensured that its quality meets the specified criteria.

1.5.3.10 Payments

Payments will only be made to the suppliers after meeting the contract/purchase order terms mutually agreed-to and all formalities are fulfilled.

Short List of Threats to Vaccine Quality

- **During shipment:** Inadequate notice of arrival, scheduling arrival during long holidays, route deviations, en route delays, cold chain breaks
- **Upon receipt:** Vaccine quality not checked
- **Central storage:** Cold chain breaks, inadequate recording, inadequate stock control system, power failure
- **Release for use :** Release certificates from the NRA in the producing country not checked, no formal release system
- **Distribution :** Freeze-dried vaccines not distributed with diluents in matching quantities, cold chain breaks, freezing of TT, hepatitis B, pentavalent, and PCV10 vaccines
- **Point of use :** Inadequate storage, reconstitution, administration, and disposal.



2. The Cold Chain System

No	Topic/Description	National		Provincial/Regional		District	Tehsil	EPI Center
		Policy	Operations	Policy	Operations			
	INTRODUCTION	✓	✓	✓	✓	✓	✓	✓
2.1	VACCINE STORAGE							
2.1.1	Vaccine potency	✓	✓	✓	✓	✓	✓	✓
2.1.2	Vaccine stock quantities	✓	✓	✓	✓	✓	✓	✓
	How much vaccine is needed at each level of the cold chain?	✓	✓	✓	✓	✓	✓	✓
2.1.3	Vaccine stock records	✓	✓	✓	✓	✓	✓	✓
s2.1.4	Vaccine arrival report		✓		✓			
2.2	COLD CHAIN EQUIPMENT AND ITS USES							
2.2.1	Equipment for vaccine transportation	✓	✓	✓	✓	✓	✓	✓
2.2.2	Equipment for vaccine storage		✓	✓	✓	✓	✓	✓
2.3	MAINTENANCE OF COLD CHAIN EQUIPMENT							
2.3.1	Installation		✓		✓	✓		
2.3.2	Defrosting		✓	✓	✓	✓	✓	✓
2.3.3	Cleaning					✓	✓	✓
2.3.4	Safety requirements		✓	✓	✓	✓	✓	✓
2.4	CONTROL AND MONITORING OF TEMPERATURES							
2.4.1	Thermometers		✓	✓	✓	✓	✓	✓
2.4.2	Temperature record sheets		✓	✓	✓	✓	✓	✓
2.4.3	Refrigerator or freezer thermostats		✓	✓	✓	✓	✓	✓
2.4.4	Cold chain monitor card		✓	✓	✓	✓	✓	✓
2.4.5	Temperature Data Logger		✓	✓	✓	✓		
2.4.6	Vaccine Vial Monitor (VVM)	✓	✓	✓	✓	✓	✓	✓

2.4.7	TT vaccine shipping indicators	✓	✓	✓	✓			
2.4.8	Freeze-Watch indicator	✓	✓	✓	✓			
2.4.9	Stop-Watch indicator	✓	✓	✓	✓			
2.4.10	Vaccine shake test	✓	✓	✓	✓	✓	✓	✓
2.5	COLD CHAIN DURING IMMUNIZATION SESSIONS							
2.5.1	At the beginning of the working day							✓
2.5.2	During immunization sessions at fixed health facilities							✓
2.5.3	At the end of the working day							✓
2.5.4	During outreach immunization sessions							✓
2.6	BREAKDOWNS & EMERGENCIES							
2.6.1	Technical faults in the refrigerator					✓	✓	✓
	How to use the checklists					✓	✓	✓
2.6.2	Plan for cold chain emergencies					✓	✓	✓

2.1 Introduction

The cold chain system is used to store and transport vaccines, in a potent state, from the manufacturer to the person being immunized. This is a very important component of an immunization program, because all vaccines lose potency over time, especially if exposed to heat; in addition, some vaccines lose their potency if they are frozen. It is obviously pointless to immunize with impotent vaccine, and efforts to reach extremely high levels of immunization coverage will be useless if the vaccine being administered has insufficient potency to give the necessary protection. Therefore, maintaining the correct temperatures during storage and transport of vaccine is a major task for health workers.

The cold chain system comprises three major elements:

1. Personnel who use and maintain the equipment and provide the health service.
2. Equipment for safe storage and transportation of vaccines.
3. Procedures to manage the program and control distribution and use of the vaccines.

Competent personnel and efficient procedures are a vitally important part of the cold chain system:

Figure 9, a typical cold chain system, shows the various steps that may be involved in delivering vaccine from the manufacturer to the person being immunized. Not all countries have an identical system, but in all countries, the vaccine must always be maintained at a safe temperature throughout its entire journey—during transport; while waiting at the airport; when being kept in cold store, freezer, or refrigerator; and, finally, during the immunization session at the health facility.

Figure 9. Cold Chain System

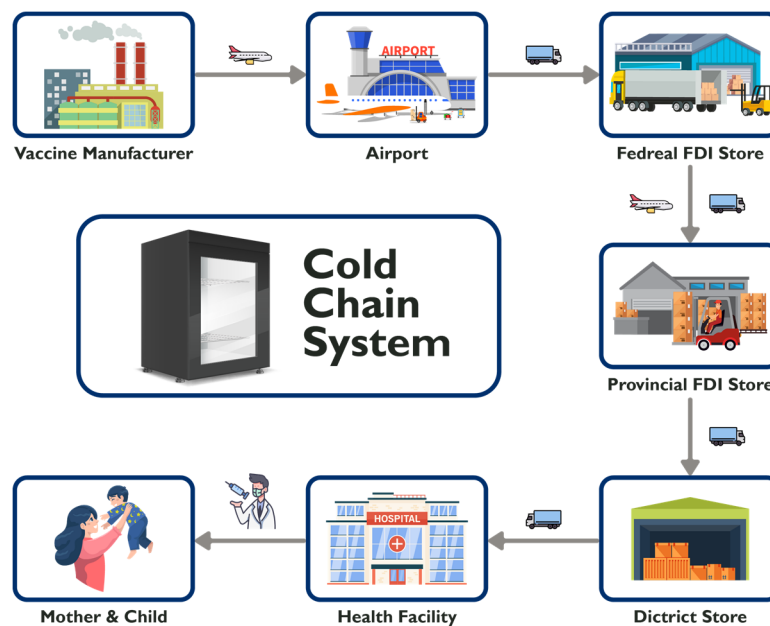

REMEMBER:

Even the most expensive and sophisticated equipment will not ensure an effective cold chain if not correctly used and managed by health personnel.

2.2 Vaccine Storage

Table 6 shows the maximum times and temperatures for storing vaccines at different levels of the cold chain, as recommended by WHO. During transport between one level and the next, all vaccines must be maintained at a temperature between +2° and +8°C. If unopened OPV become unfrozen during transit, it can be safely refrozen at the next level without any harm or loss of potency to the vaccine.

Table 6. Recommended Vaccine Storage Temperature/Times for Different Levels of the Cold Chain

Vaccine	Primary	Intermediate		Health Center	Outreach site
	Federal	Provincial	District Store	DHQ, THQ, RHC, BHU	
Maximum storage time	Up to 6 months	Up to 3 months	Up to 1 month	Up to 1 month	Daily use
OPV	-15° to -25°		+2° to +8°C		
Measles and rubella	WHO no longer recommends that freeze-dried vaccines be stored at -20°C. Storing them at -20°C is not harmful, but it is unnecessary. Instead, these vaccines should be refrigerated and transported at +2° to +8°C.				
BCG					
IPV					
Hepatitis B					
Pentavalent					
PCV13					
Rotavirus					
Td					

Notes:

- (1) Measles and rubella and BCG vaccines must be stored at +2° to +8°C.
- (2) Table 6 shows the maximum storage times at each level. Maximum times are based on the relative security of storage expected at each level; together, they ensure that any vaccine will take, at most, one year to be sent through the cold chain and be used. Normally, it is expected that most vaccine stocks will be used before the maximum time is reached.
- (3) Remember to check the expiry dates of all vaccines and ensure that they will not expire during storage or before they can be distributed and used.
- (4) Rotate vaccine stock: Vaccine received first should be distributed or used first unless a VVM shows that another batch should be distributed or used first—early-expiry, first-out (EEFO); first-in, first-out (FIFO); and first-to-expire, first-out (FEFO).

IMPORTANT!

- Vaccine must always be transported in refrigerated vehicles, insulated/cold boxes with sufficient icepacks/cool-packs to ensure it remains between +2° and +8°C.
- Vaccines must not be kept in—
 - Door compartments
 - Salad trays
 - Contact with the evaporator plate.
- This prevents damage to the potency of the vaccine.
- Diluents can be stored at room temperature, but should be refrigerated with the vaccine in between +2° to +8°C for at least 12–24 hours before use.

To summarize:

- At the national level, keep the vaccines for a maximum of six months:
 - Store OPV at -15° to -25°C
 - Store all other vaccines at +2° to +8°C
 - Send vaccines to provinces/regions in insulated containers or refrigerated vehicles at +2° to +8°C.
- At the provincial level, keep the vaccines for a maximum of three months:
 - Store OPV at -15° to -25° C
 - Store all other vaccines at +2° to +8°C
 - Send vaccines to divisions/districts in insulated containers or refrigerated vehicles at +2° to +8°C.
- At the district level, keep the vaccines for a maximum of one month:
 - Store all vaccines at +2° to +8°C
 - Send vaccines to health facilities in cold boxes or refrigerated vehicles at +2° to +8°C.
- At the health facility level:
 - Keep all the vaccines for a maximum of 15 days
 - Store all vaccines at +2° to +8°C.
- Use the vaccines first if they have been stored for more than the recommended period, have not expired, and they meet other criteria for viability

REMEMBER!

- Storage times shown are maximum periods at each level.
- If the cold chain equipment is not reliable, storage times should be less than these, keep small amounts stored, and make deliveries more often to minimize the risks of damage and loss.
- Even if storage temperatures are always correct, check the expiry dates.

2.2.1 Vaccine potency

If a vaccine loses some or all of its potency due to exposure to heat, its outward appearance may be unchanged. Previously, a laboratory test was needed to determine whether it could still be used. The Cold Chain Monitor (CCM) card was the first device to visually indicate the possible loss of potency in a carton of vaccine because of exposure to temperature. The vaccine vial monitor (VVM) (see section 2.6), a small indicator attached to each vial, keeps a constant record of its exposure to heat. If the vaccine is exposed to temperatures above +8°C, the indicator progressively changes color; health staff know immediately if the vaccine has been damaged.

2.2.2 Vaccine stock quantities

It is important for the correct quantity of vaccine stock to be kept at each level of the cold chain. If you keep too little vaccine, health facilities may run out of stock and the immunization program may be interrupted. On the other hand, if you keep too much vaccine, the cold chain may have insufficient storage space, some vaccines may be stored longer than recommended and may expire before they can be used; also, there may not be enough vaccine to supply to other parts of the country.

How much vaccine is needed at each level of the cold chain?

To estimate the quantity of vaccine needed for primary immunization in any area (i.e., for a health facility, tehsil, district, or for the whole country), the following information will be needed:

- Number of children in the area to be immunized during the next 12 months
- Number of doses needed per child for each vaccine
- Estimated index of vaccine used (also called wastage factor) for each vaccine
- Number of vaccine deliveries planned for the next 12 months
- Amount of reserve vaccine stock (percentage) to be kept in the main store of the area
- Balance of vaccine stock remaining in the main store at the date of the estimate

The following points should be kept in mind when estimating vaccine needs. They will help you avoid some mistakes which commonly occur during the preparation of estimates.

(1) Number of children to be immunized

For primary immunization, this is the total number of children expected to be born in the next 12 months in the area you are estimating. (i.e., in the territory of the health facility, the tehsil, the district, or in the whole country). This will be a projection; you can use the number of newborns from the previous year for the estimate.

Remember, do not subtract the number of children who might have temporary or permanent contraindications to immunization. All children must be included in the annual plan for primary immunization; add to this year's total any children from the previous year who have not received their primary immunization (backlog).

(2) Number of doses needed per child

This is based on the national immunization schedule; the primary series (during the first two years of life) may include—

BCG	1 dose
OPV	4 doses
IPV	2 dose
Pentavalent.....	3 doses
Pneumococcal	3 doses
Rota virus.....	2 doses
Measles and rubella	2 doses
Typhoid.....	1 dose

For revaccinations, using the national immunization program schedule, calculate dose requirements separately.

Similarly, for mass immunizations, outbreak control, or special campaigns keep calculations separate from estimates of primary immunization needs. Remember, the larger vial size may be preferable for mass campaigns.

(3) Index of vaccine use (or wastage factor)

The actual wastage factor for each vaccine can be calculated from the records of numbers of immunizations given and amounts of vaccine used during a certain period (i.e., one month, three or six months, or for a full year).

In general, the most accurate figures are obtained if long, rather than short, periods of time are used for the calculation. The wastage factor is calculated separately for each vaccine and for any period for which you have reliable records.

Use this formula:

$$\text{Index of vaccine use} = \frac{\text{Doses of vaccine used in a certain period}}{\text{(or wastage factor) Immunizations given during the same period.}}$$

The index will probably be different for each vaccine; and, for each vaccine, it may vary over different periods of time (i.e., from one year to the next). It will also vary for the same vaccine

based on the type of activity—for example, routine sessions versus mass campaigns. It is useful to calculate an average figure for each vaccine, which can be found from the records for the last five years, for example. This figure can be updated each year by adding the new data on numbers of immunizations given and amounts of vaccine used during the last 12-month period.

Always use the data to calculate actual wastage rates for a particular situation, rather than using assumed values. If there is insufficient data to make the calculation, the information system is inadequate. Take steps as soon as possible to improve recording and reporting to ensure that the necessary data can be collected and used for future calculations.

(4) Number of vaccine deliveries planned in the next 12 months

Immunization programs should have a fixed schedule for deliveries of vaccine between each level of the cold chain and the next level. Usually, the central levels will have longer delivery intervals and shorter intervals at the periphery, but they should not exceed the maximum storage periods for each level described in Vaccine Storage, section 2.1. The choice of delivery interval is always a compromise, fewer deliveries mean lower shipping charges, but more vaccine will have to be sent in each delivery; a larger and more expensive cold chain will be needed.

Many programs find that four deliveries per year at the national level, four deliveries per year at the provincial level, and 12 deliveries per year at the district- and health facility–levels give the best balance. Using figures appropriate for the program, calculate the amount of vaccine to be sent in each delivery by dividing the annual needs by the number of vaccine deliveries planned during the year.

If the cold chain equipment is not reliable, to minimize the risks of damage and loss of stock if the cold chain fails, maximum storage times should be shorter, amounts stored should remain small, and vaccine deliveries should be more frequent. Obviously, in all areas where the cold chain is unreliable, take steps to improve the situation as quickly as available resources permit.

(5) Reserve vaccine (buffer) stock to be kept in hand (in doses)

Always keep a reserve stock balance at vaccine storage points at all levels of the cold chain. This will allow for unexpected increases in vaccine use; for example, in the event of an outbreak of disease or delayed arrival of a planned vaccine delivery. The amount of reserve needed at any level depends on its remoteness from the central store, the reliability of vaccine deliveries, or the capacity of the available equipment.

Typically, the amount of reserve stock is 20–25 percent of the amount used during one delivery period. However, any amount that ensures stock never completely runs out may be appropriate, based on local experience. WHO and FDI program recommends that the buffer stock should be equal to the required consumption of the facility level.

Buffer Stocks for - national level must be equal to six months requirement

- provincial- and regional-level must be equal to three months requirement
- district- and sub-district level must be equal to one month's requirement

Maximum-Minimum Stock Levels

After the buffer stock level is determined for each storage point, this amount is called the minimum stock for the store. Never allow stocks to fall below this absolute minimum.

Lead time: This is the time from requisition till the arrival of vaccine at the facility. This varies for each level. For example, it may be two weeks for health facility and three–six months for the national level.

Reorder level: This is equal to the buffer stock level plus the lead time for the next supply.

District- and sub-district stores: If it takes two weeks for the requisition and supply of vaccine, the reorder level will be equal to a one-month buffer stock plus two weeks lead time. Thus, the reorder level for districts and sub-districts will be when the stock level reaches the six-week requirement

Provincial store: If the time for requisition and supply of vaccine is one month, then the reorder level will be equal to three months buffer stock plus one-month lead time. Thus, the reorder level for the provincial store will be when the stocks level reaches the four-month requirement.

National store: If the time for requisition and supply of vaccine is four months, then the reorder level will be equal to six months buffer stock plus four months lead time. Thus, the reorder level for the national store will be when the stocks level reaches 10 months requirement.

The maximum stock to be kept at any storage point should equal the reorder level plus the buffer stock for that level.

Example of maximum stock level for a district store will be—

Reorder level 1½ month + Buffer stock 1 month = Maximum stock of 2½ months

If the immunization program is running normally, the amount of stock at each storage point should always remain between these two levels, never more than the maximum and never less than the minimum. This would indicate a well-run store, with good stock control.

(6) Balance of vaccine stock remaining in the store (in doses)

All the calculations above will determine vaccine needs; but normally, this is not the amount to be ordered or purchased. Now, the balance of vaccine stock remaining in the store must be checked; subtract this from total calculated needs. If this last, but very important step, is not done, the result is often large overstocks accumulating, serious overcrowding of cold chain equipment, and expired vaccines.

(7) Vial sizes to order

The most useful size of vial to order (1-, 2-, 5-, 10-, or 20-dose, etc.) depends on the type of immunization being conducted (routine or mass campaign), the number of people to be served, and the number of health facilities where the vaccine will be sent. For example, 1,000 doses in 20-dose vials yields 50 vials for distribution; but 10-dose vials yield 100 vials for distribution.

However, remember that smaller vial sizes are usually more expensive, so you may need to compromise.

2.2.3 Vaccine stock records

All vaccine storage points must keep a complete and updated stock record register. Minimum information to be recorded for each vaccine should include—

IMPORTANT!

- Always subtract the stock balance remaining in the store from calculated total needs before placing the vaccine order.
- Always specify the vial size required when ordering.

And remember!

- All calculations and estimates must be in doses of vaccine. Do not confuse doses with numbers of vials and ampoules.
- name of vaccine, batch number, expiry date, and vial size
- quantity received (in doses) and sources of supply
- quantity issued (in doses) and to whom it is sent
- for BCG and measles and rubella, quantities of diluent received and issued
- balance in stock after each transaction (in doses)
- date of each transaction
- physical stock check (in doses) at the end of each page.

The store keeper or person responsible for the vaccines must keep the record; it must be updated every time vaccine is received or issued from the store or the ILR, in case of the EPI center. A record that is not kept up to date provides false information and is useless for the manager. It can also cause over- or understocking of the store and can affect the service delivery.

The stock record must also be checked regularly for accuracy. This can be done by physically counting the actual quantities of vaccine in stock and compare this to the amount shown in the stock record register. Any difference must be immediately corrected by updating the record to show the correct figures. The check for accuracy should be done at the end of each page in the record register, or at the end of each month, if this is reached before the end of one page.

All transactions of vaccines must be entered in the vaccine logistics management information system (vLMIS).

ESSENTIAL ACTIONS!

- Update the stock record every time vaccine is put in or taken out of the store/ILR.
- Record the quantity of diluent provided with freeze-dried vaccines. Never issue freeze-dried vaccines without the correct diluent.
- Always complete the stock balance figure, so a constant record of stock is always available.
- Conduct a physical check for accuracy at the end of each page in the record book, or at the end of each month (if this is reached before the end of one page).
- Enter all transactions of vaccines in the vLMIS.

2.2.4 Vaccine Arrival Report

At the national- and provincial-level, the store-in-charge must keep a record of the details and arrival conditions of all vaccine deliveries received at the store using a special document—a Vaccine Arrival Report (VAR). This is required, in addition to the normal receipt issued whenever supplies are delivered. A VAR is required for every vaccine shipment received from a manufacturer. The document provides vital information, including cold chain status during transportation for the health department/ immunization program; it will also be essential if this vaccine was provided through a program of technical assistance or other donor support to the program.

2.3 Cold Chain Equipment and its uses

As shown in section 2.2, different vaccine storage conditions are appropriate for each level of the cold chain. Thus, each level requires different storage equipment, depending on the quantity of vaccine to be stored, the duration of storage, and the required temperature. All equipment must be able to keep vaccines safe, irrespective of the outside temperature, or the climate variations at different times of the year.

Also, different types of equipment are designed to transport vaccines between the various levels of the cold chain and for use during immunization sessions.

All types of cold chain equipment contain one or more of a series of organic gas compounds, used either as their working fluid, in the manufacture of their insulation, or both. These gas compounds, known as chlorofluorocarbon (CFC) gases, were once considered ideal for the cold chain, but now it's known they are harmful if they escape into the environment. A new range of cold chain equipment was introduced in 1996 to replace those using CFC gases. The new equipment is described as being CFC-free equipment. The symbol, shown in

Figure 10, is placed on refrigerators, cold boxes, and vaccine carriers to indicate that the equipment has been made using CFC-free material for the insulation and CFC-free gas for the refrigerator's cooling system. These materials are less harmful to the environment than those previously used.

Figure 10. WHO/FDI Symbol for CFC-Free Cold Chain Equipment

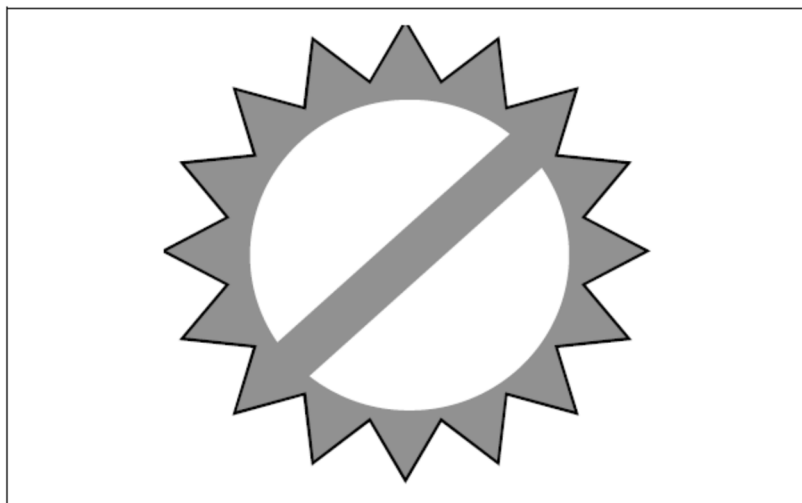

All cold chain equipment must pass WHO tests before it can be used in national immunization programs.

To maintain a continuous cold chain from the vaccine manufacturer to the person being immunized, it is most important that the equipment used for storage, packaging, and transport of vaccine is used properly. The following points will help you use the equipment correctly.

2.3.1 Equipment for vaccine transportation

For transportation of vaccines from one place to the other following equipment/items are used to maintain the cold chain:

- Cold boxes
- International vaccine packaging containers
- Vaccine carriers
- Icepacks
- Refrigerated vehicles (trucks)

All transportation links in the cold chain must protect vaccines from heat and sunlight. However, in some winter conditions, when atmospheric temperatures are below 0°C, you must take measures to prevent vaccines from freezing. Cold boxes and vaccine carriers are designed to provide the required protection.

The cold life of a cold box or vaccine carrier is the number of hours it will keep the vaccines at a safe temperature. According to WHO test procedures, it is the number of hours the cold box or vaccine carrier will maintain a temperature below +10°C, after it has been loaded with the recommended number of frozen icepacks. The cold life of each cold box or vaccine carrier differs and depends on the following factors:

- Type of cold box or vaccine carrier, insulation material, thickness, method of construction, and foaming agent used.
- Mass and initial temperature of icepacks put into the cold box or vaccine carrier.
- Number and duration of openings.
- Surrounding air temperature; this factor greatly affects the cold life—the lower the air temperature, the longer the cold life

In the winter, certain areas have extremely low air temperature. The transport of pentavalent, TT, and hepatitis B must be done with utmost care to avoid freezing the vaccines. The cold box must protect vaccines from becoming too cold; the warm life is the number of hours it will keep the vaccines above their freezing point. To protect these vaccines from freezing under winter conditions, the following measures will help:

- Fill the icepacks with water from the tap, but do not freeze them.
- Keep pentavalent, TT, and hepatitis B in the center of the cold box or vaccine carrier, and as far away as possible from the icepacks.
- Use a Freeze-Watch indicator, in addition to the normal CCM and thermometer (refer to section 2.5).
- Do not leave the cold box or vaccine carrier outdoors or in very cold rooms for longer than necessary.
- Do not leave cold box or vaccine carrier in unheated transport longer than necessary.

2.3.1.1 Cold boxes

A cold box is an insulated container with a tight-fitting insulated lid. Icepacks maintain the temperature inside the box. The cold box is designed for—

- Collecting and transporting large quantities of vaccine at temperatures between 2° to +8°C
- Storing vaccine during maintenance periods (e.g., when cleaning or defrosting a refrigerator or freezer)
- Storing vaccine in an emergency (e.g., during breakdown of cold chain equipment, power failures, or similar situations)

Different levels of the cold chain require different types and sizes of cold boxes, depending on the population served (see Figure 11).

Figure 11. Cold Box Used in the Cold Chain

(Small, long range, vaccine storage capacity 7 liters; cold life 114 hours)



2.3.1.2 International vaccine packaging containers

Internationally procured vaccines are transported in vaccine packaging containers, sometimes called one-way containers. They are made of polystyrene foam and are quite sturdy, give good protection from heat and cold, and conform to WHO/UNICEF guidelines for international vaccine shipping.

Containers can be used as a cold box at the regional- and district-level if they are in good condition, (i.e., not broken, partly torn, or damaged). The containers used in international shipments of polio or measles and rubella vaccine are best for this, although not as good as a real cold box.

When used, these containers should be loaded with vaccine and icepacks in the same way as a regular cold box (see below).

NOTE:

The cold life of one-way shipping containers is not as good as those of real cold boxes. Limit their use to the less heat sensitive vaccines—TT, hepatitis B, as far as possible.

How to load a cold box (see Figure 12)

Remember, pentavalent, PCV13, Td, and hepatitis B vaccines must not be frozen (refer to Table 2).

Figure 12. How to Load a Cold Box

1. Place ice packs in the bottom

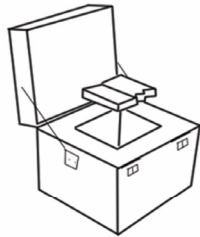

2. Place ice packs on all sides

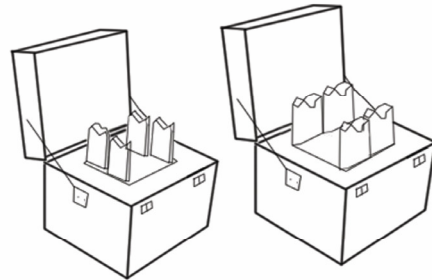

3. Place Vaccines into cold box

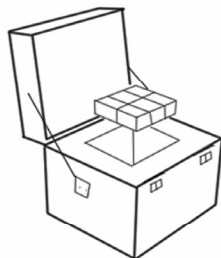

5. Place ice packs on top

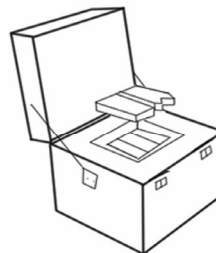

If vials of vaccines make direct contact with frozen icepacks in a cold box, they can easily freeze, and the vaccine will be destroyed. To avoid such damage:

- Condition icepacks: Do not take icepacks from the freezer and place them directly in a cold box with these vaccines; leave the icepacks out for a few minutes until water droplets appear on their surface before putting them in the cold box.
- Place a layer of plastic foam, cardboard, or similar packaging material between the vaccine packets or vials and the icepacks. This will insulate and protect vaccines from freezing.

For other vaccines (i.e., OPV, measles and rubella, and BCG) these precautions are not necessary; icepacks can be placed in a cold box directly from the freezer. Prepare a cold box as follows:

- Take the required number of icepacks from a freezer.
- If required, wait a few minutes until water droplets appear on the surface.
- Wipe the icepacks dry and place them so they cover the bottom and internal walls of the cold box.
- If needed, place plastic foam, cardboard, or similar material to protect pentavalent, PCV13, IPV, Td, and hepatitis B vaccines.
- Place vaccines, thermometer, and/or CCM card carefully in the box; (if several types of vaccines are being sent together, put OPV, measles and rubella, and BCG at the bottom and closest to the icepacks; place pentavalent, etc., in the center and far away from the icepacks.
- Place cardboard or similar material and additional icepacks on top of the vaccines.
- Close the lid tightly.
- Do not include diluent for freeze-dried vaccines in the cold box; it does not need to be kept cold during transport and it will take up space in the cold box.

Don't use excessive ice, especially for short journeys with pentavalent or other adsorbed vaccines.

2.3.1.3 Vaccine carriers

A vaccine carrier is an insulated box with a tight-fitting insulated lid. Icepacks will maintain the temperature in the vaccine carrier.

The vaccine carrier is designed for—

- Transporting small quantities of vaccine between 2° to 8°C within one working day.
- Storing small quantities of vaccine needed for immunization during the working day to avoid frequent opening of the refrigerator.
- Storing small quantities of vaccine in emergency situations (e.g., during cold chain equipment failures, power failures, and similar situations).

Some vaccine carriers now have a foam pad fitted under the lid (see figure 13); the pad has slits that safely hold opened vials in use; it also protects the other, unopened vials inside the carrier. This prevents having to open and close the lid each time an opened vial is needed.

Figure 13. Vaccine Carriers



How to load a vaccine carrier

Follow the same instructions (see Figure 14) for loading a cold box, but note that diluents for freeze-dried vaccine should be packed with the vaccines. Instructions are otherwise identical.

Figure 14. How to Load a Vaccine Carrier

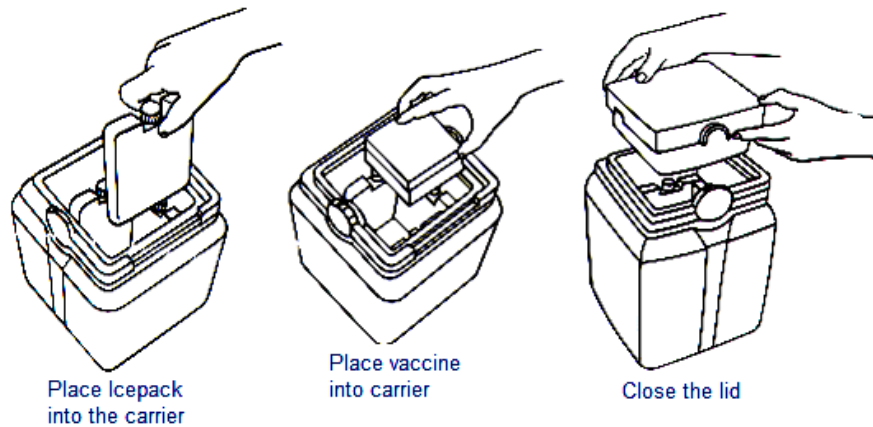

2.3.1.4 Icepacks

Icepacks are rectangular plastic containers that are filled with plain water. They come in many different sizes, although WHO recommends only two sizes:

- 0.4 liter to be used with vaccine carriers
- 0.6 liter to be used with cold boxes

The icepacks, once frozen, will maintain the temperature between +2 and +8°C in cold boxes and vaccine carriers.

Always have two sets of icepacks for each cold box or vaccine carrier—one set to be frozen while the other is being used.

Figure 15. How to Fill an Icepack



How to prepare icepacks

- Fill the icepack with water to level A (see Figure 15); this will allow room for the water to expand as it freezes. Most icepacks indicate the maximum admissible water level
- Fit the sealing plug (if applicable) and screw the lid on tightly; make sure there are no leaks
- Place the icepacks in a freezer or a freezing compartment of a vaccine refrigerator/ILR. For faster freezing, arrange the icepacks on one edge so as many as possible have contact with the evaporator. See Figure 16.
- It normally requires 12 hours in a freezer and 24 hours in a freezing compartment of a refrigerator/ILR for an icepack to completely freeze

Figure 16. Arranging Icepack for Freezing

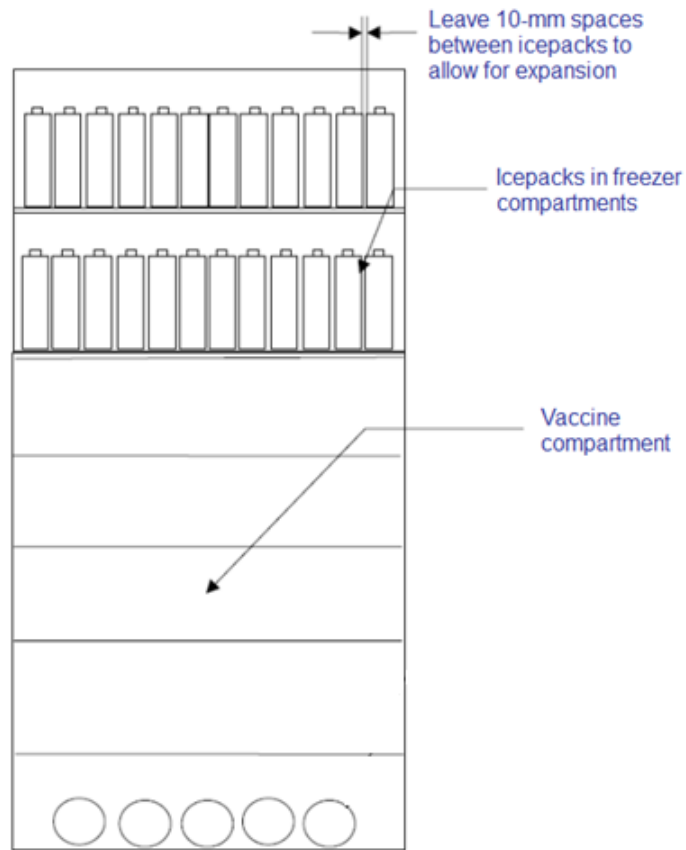

2.3.1.5 Refrigerated vehicles/insulated vehicles

A refrigerator vehicle is a van or truck designed to carry vaccines at specific temperatures. Refrigerated trucks differ from simple insulated and ventilated vans—commonly used to transport fruit—neither of which are fitted with a cooling apparatus (see figure 17). Refrigerator trucks can be ice-cooled, equipped with a variety of mechanical refrigeration systems, powered by small displacement diesel engines, or use carbon dioxide (either dry ice or liquid) as a cooling agent.

Figure 17. Refrigerated Vehicles



2.3.2 Equipment for vaccine storage

Cold chain equipment designed for vaccine storage has to meet two major requirements:

- It must ensure optimum temperature conditions for vaccine storage all year.
- It must be large enough to hold the maximum vaccine stock to be stored at the level of the cold chain where it will be used.

The different quantities of vaccine to be stored at each level in the cold chain require different equipment. Regular temperature monitoring is essential for all types.

National Level

At the national level, the following equipment is normally used:

- Cold rooms or large top-opening refrigerators
- Freezer rooms
- Icepack freezers.

2.3.2.1 Cold room

A cold room is a store where a refrigerating unit generates and maintains the required temperature conditions, between 2° to +8°C (see Figure 18 and 19).

Figure 18. Cold Room or Freezer Room (prefabricated modular walk-in for storage of vaccines)

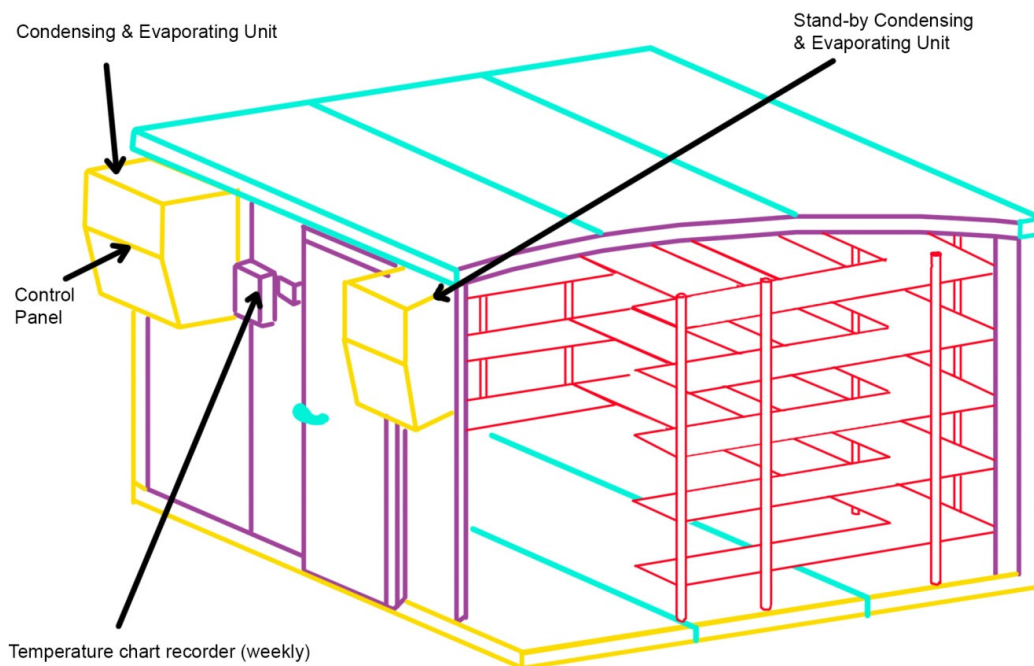

Figure 19. Cold Room 50 m³ Capacity at Store



Cold rooms are used to—

- Store very large quantities of vaccine between +2° to +8°C
- Provide a secure facility for national- or provincial-, and regional–reserve stocks
- Provide a national- or sub-national–distribution point

A cold room is a complex engineering structure. Trained workers, both for the vaccine storage and for the technical maintenance, must operate it. Remember the following points for loading, unloading, and maintaining a cold room:

- Mark specific areas for each vaccine type.
- Leave spaces between each row of vaccine boxes to allow free circulation of the cool air.
- Do not place pentavalent, TT, IPV, or hepatitis B vaccines in the direct airflow from the cooling machinery because they may freeze.
- Unpack, sort, and package the vaccine into cold boxes inside the cold room or in a cool place nearby.
- Change paper charts for recording thermometers regularly (usually each week); write on each chart the date of the recording period.
- If there is a standby generator, ensure that it always has an adequate fuel supply, and regularly check for appropriate operation. Run it for approximately one hour, at least once every week.

2.3.2.2 Freezer room

A freezer room generates and maintains temperatures between -15° and -25° C. They are designed to keep very large quantities of OPV in a frozen state (see figure 20). The main operational points are the same as those for a cold room (refer to section 2.2.2.1). However, always use gloves and warm clothes when working inside the freezer room.

Figure 20. Freezer Room 50 m³ Capacity at Store



IMPORTANT!

- Do not allow anybody to enter the cold room for more than five minutes without wearing suitable clothing. A person who is not wearing warm clothing must be accompanied at all times.
- Do not allow anybody to enter the freezer room unless they are wearing suitable clothing.
- Suitable clothing for a cold/freezer room includes thermal trousers, a thermal jacket, gloves and a hat.

2.3.2.3 Top-opening freezer

A freezer generates and maintains a temperature between -15° and -25° C. Freezers are used to—

- Store OPV between -15° and -25° C
- Store frozen icepacks and, if necessary, freeze icepacks

Top-opening freezers are frequently used at national-, regional-, or district–vaccine stores where large quantities of frozen vaccine are kept. Remember the following points when using top-opening freezers:

- Always keep the thermostat adjusted between -15° and -25° C.
- If vaccines and icepacks must be kept in the same freezer, put in only small quantities of water-filled packs at a time. Adding a large quantity of unfrozen icepacks at one time can raise the temperature to a level that endangers the vaccine.

Figure 21. Top-Opening Freezer



Figure 22. Icepack Freezer



2.3.2.4 Icepack freezer

A special, front-opening freezer (see figure 22) is used at the national level and, sometimes, at the regional level to freeze large quantities of icepacks. It can hold up to 136 large icepacks (0.6 liter) and freezes them faster than an ordinary chest freezer. Performance depends on air temperature, but at least 60 large icepacks can be frozen in 24 hours.

Remember the following points when using an icepack freezer:

- Freeze as many icepacks as possible at one time; after freezing, store them in a chest freezer, if available.
- Place the icepacks on the edge so the maximum number can be in direct contact with the shelves. Leave a 1cm space between each, because they expand when frozen.

SUMMARY POINTS!

- At the national store, keep all vaccines for a maximum of six months.
- Store OPV in freezer rooms or freezers at -15° to -25°C .
- Store pentavalent, PCV13, Td, BCG, and hepatitis B vaccines in cold rooms or refrigerators at 2° to $+8^{\circ}\text{C}$.
- Do not freeze any diluents. Store the diluent in the refrigerator at 2° to $+8^{\circ}\text{C}$; ensure that the quantity and type of diluent match the freeze dried vaccines in stock.
- Do not put too large quantities of unfrozen icepacks into a chest freezer that contains OPV; use the icepack freezer to freeze them first, and then transfer them to the chest freezer for storage.

Provincial/Regional Level

At the provincial- and regional-level, the following equipment is normally used:

- Freezer rooms, cold rooms
- Large top-opening freezers/ILRs
- Icepack freezers

2.3.2.5 Voltage stabilizers; selection and use

Some cold chain equipment—ILRs, refrigerators etc.—that uses electric power is designed to be used with a specific electrical supply voltage; or, in some cases, with a choice of several different supply voltages. If the supply voltage is incorrect or fluctuates from the correct value, the cold chain equipment can easily be damaged. This could result in costly replacement of motors, compressors, heater elements, or other electrical components.

Figure 23. Voltage Regulator



Problems with power supplies:

The power supply may be incorrect in several ways, the—

- Supply voltage may be constantly higher or lower than the design voltage
- Supply may be intermittent, with frequent outages and reconnections
- Voltage may fluctuate frequently from the correct value, with sudden surges of excessive voltage

Each situation can cause immediate damage to cold chain equipment; the damage, however, can be prevented or reduced by installing a voltage regulator between the cold chain equipment and the electrical supply point (see figure 23). This corrects the supply voltage, removes the fluctuations, and protects the equipment. A voltage regulator will add to the capital cost of the cold chain, but should prolong the life of equipment and, in areas with poor power supply, is usually cost effective.

Types of voltage regulator

(1) Pure transformer regulators are the most reliable type because they have no moving parts or electronic components, but they are usually the most expensive. This type uses a combination of magnetic flux and transformer principles to monitor the supply voltage; if it is incorrect, the transformer regulates it to the correct value, as required by the equipment.

(2) Solid state regulators are, also, generally reliable and have no moving parts; but, they use electronic components to monitor the supply voltage and, if necessary, apply a correction. This type is less expensive than the pure transformer type; it is the most commonly used for small- and medium-size cold chain equipment. These regulators are available for both inductive-load equipment (compression refrigerators or freezers) and for resistive-load equipment (absorption refrigerators or steam sterilizers).

(3) Electronic servo regulators contain electric motors and actuators with variable voltage transformers and electronics to monitor the supply voltage; and, if necessary, regulate the output to the equipment. Because the output voltage is motor-regulated, this type is very accurate and can control over a wide range of voltages. Costs are generally less than the types described above, but the moving parts mean that it is more complex and more sensitive; unless it receives proper care, it may cause problems.

How do you know if a voltage regulator is needed?

A voltage regulator should be considered an essential item of capital equipment in any of the following situations:-

- Areas where room lights often change suddenly from bright to dim, or become very bright for short periods.
- Any area where the room lights are often dimmer than expected.
- All areas where power supplies are irregular, or where cuts and interruptions are common.
- All areas where other equipment that use the electricity supply—light bulbs, TV sets, radios, domestic appliances—need to be repaired or replaced frequently.
- All national-, regional-, or provincial—cold stores, freezer stores, or other cold chain equipment where large amounts of vaccine will be stored.

In addition to observing the effects of unreliable power supplies, an electrical technician should measure the actual supply voltage at the point where cold chain equipment is used, or where an installation is planned. To confirm whether or not the supply is unreliable, the voltage must be measured at frequent intervals during as long a period as practicable—several days, at least—particularly when cuts are known to occur; or during mealtimes, etc., when many others may be using the same supply. If measurements show a fluctuation of more than 10 percent above or below the expected standard voltage in the area, a voltage regulator is strongly recommended.

How to select the correct voltage regulator

The technical specification for a voltage regulator will cover a number of features, but selection must be based initially on four important characteristics:

- Nominal voltage
- Supply voltage range

- Output voltage range
- Power rating

The nominal voltage is the electrical supply voltage measured in volts (V) specified for the equipment it is to protect. This may be, for example, 220 volts; the regulator selected must have a nominal voltage rated at this same value.

The supply voltage range defines the maximum and minimum supply voltage (e.g., 145–275 V) that the regulator can provide protection for the equipment. This range should be greater than the highest and lowest supply voltages measured at the point where cold chain equipment is used.

The output voltage range specifies the maximum and minimum voltages (e.g., 200–225 V) that the regulator will pass on to the equipment it protects. This range should be less than the maximum and minimum permitted voltages stated by the equipment manufacturer.

The power rating is the load carrying capacity of the regulator; it is measured in volt-amps (VA) or in watts (W). The power rating, usually specified as the continuous rating (e.g., 500 W continuous); it must be greater than the power rating of the equipment to be protected. Power ratings for both cold chain equipment and regulators are shown on data plates attached to an outer surface, usually on the back of a refrigerator or freezer, and on the top or underside for a voltage regulator.

After making an initial selection of a regulator based on key technical specifications and other factors—such as time-delay protection against short-term high or low voltages—you can consider indicator lights to show operational status, cost, etc.

2.3.2.6 Ice-lined refrigerator

This type of refrigerator is specially designed for vaccine storage (see figure 24); it is different from a normal top-opening refrigerator (see figure 20). It comes in various sizes for use at different levels in the cold chain. The design is top-opening because this type holds the cold air inside better than a refrigerator with a front-opening door. It can keep vaccine safe with as little as eight hours of electricity supply in a 24-hour period. Inside the refrigerator, a lining of water containers—icepacks or tubes—are fitted around the walls and a frame holds it in place. While the refrigerator is operating, the water in the containers freeze; if the electricity supply fails, the lining of ice keeps the inside temperature of the refrigerator at a safe level for vaccines for much longer—usually for at least two days, if the door is not opened frequently.

This type of refrigerator has a heavy-duty compressor, which will start at a low voltage and continue to operate even when there are large variations in supply voltage.

For instructions to use in Urdu, see appendix H.

Figure 24. Ice-Lined Refrigerator

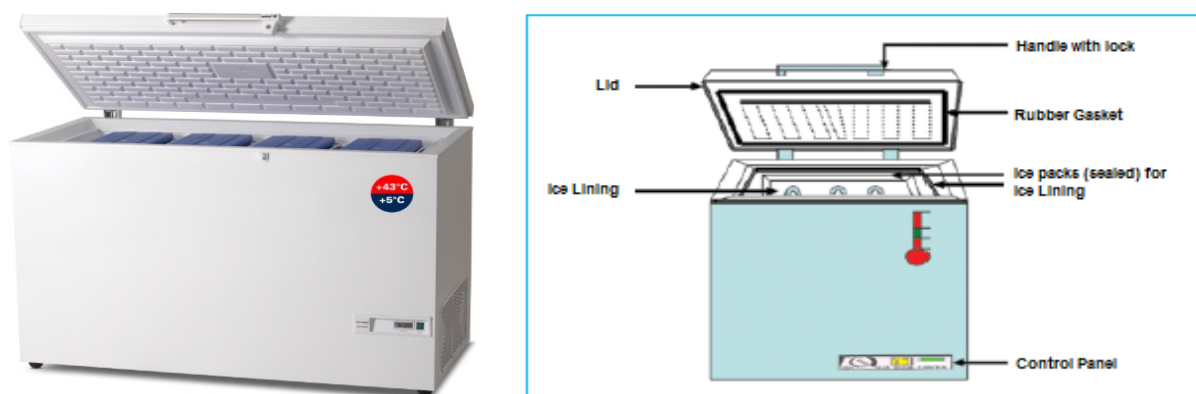

Points for installing and using an ILR

- Using the manufacturer's instructions, install the lining of water containers completely.
- After adjusting the thermostat, allow at least 24 hours for the temperature inside to change.
- The change in temperature takes longer than a household refrigerator because of the ice-lining.
- Put BCG—and polio and measles and rubella vaccines, if not kept in a separate freezer—in the bottom, where it is coldest.
- Put TT, PVC10, IPV, and hepatitis B or pentavalent vaccines in the baskets, near to the top. To avoid accidental freezing, do not put these vaccines within 15cm of the bottom of the compartment.
- In winter, or whenever the room temperature drops below +10°C, carefully check the temperature, thermostat adjustment, and condition of the adsorbed vaccines. During these conditions, the refrigerator may easily get too cold inside, even if the thermostat is at its highest setting.

SUMMARY POINTS!

- At the provincial/regional level keep vaccines for a maximum of three months.
- Store OPV in freezers at -15° to -25°C.
- Store measles and rubella, Td, BCG, hepatitis B, PCV13, IPV, and pentavalent vaccines in refrigerators, preferably ILRs, at 2° to +8°C.
- In very cold weather, pay special attention and frequently check the temperature.

District Level

The following equipment is normally used at the district level:

- Cold rooms
- Top-opening or ILR
- Top-opening freezers

SUMMARY POINTS!

- At the district level, keep vaccines for a maximum of one month.
- Store all vaccines in refrigerators at 2° to +8°C.

Health facility level

One or more of the following types of equipment is normally used at the health facility level:

- ILRs
- top-opening freezer.

SUMMARY POINTS!

- In health facilities, keep vaccines for a maximum of one month.
- Store all vaccines in the ILR at +2° to +8°C.
- Place OPV and measles and rubella vaccine closest to the evaporator.
- Place Td, BCG, pentavalent, PCV13, IPV, and hepatitis B away from the evaporator.

2.3.2.8 Solar Refrigerator

A solar refrigerator (see **Error! Not a valid bookmark self-reference.**) operates on the same principle as a normal compression refrigerator, but it uses low voltage (12 or 24V) DC compressors and motors, instead of normal voltage AC types. To maximize energy efficiency, a photovoltaic refrigerator has higher levels of insulation around the storage compartments; a battery, or number of batteries depending on the size of the panel, for electricity storage; a battery charge regulator; and a controller that converts the power from the battery to the DC form required by the compressor motor.

Figure 25. Solar Powered Refrigerator

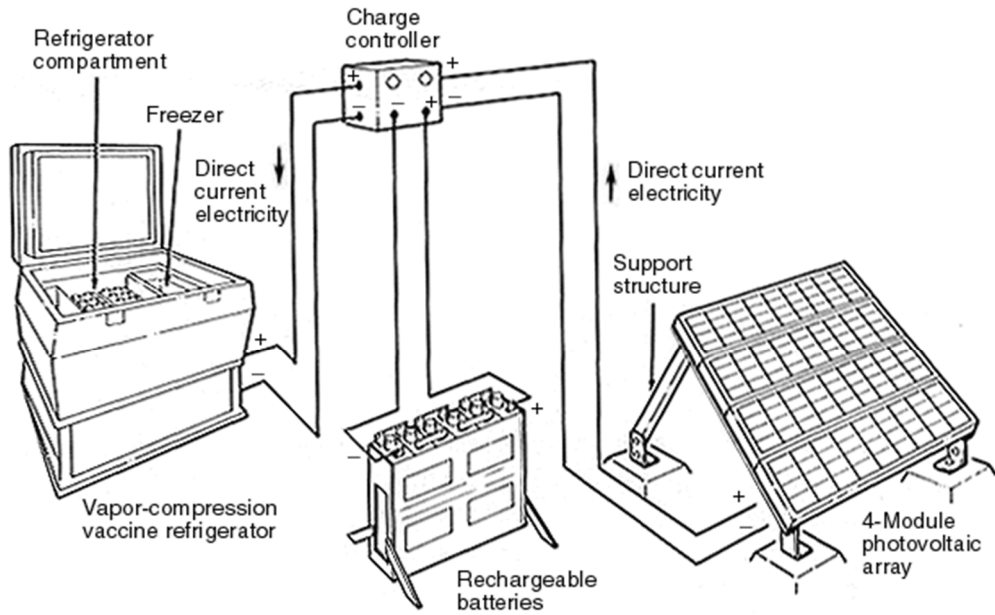

Vaccine Refrigerator Powered by a Photovoltaic System



Components of solar refrigerator

- **Vaccine refrigerator/freezer:** This refrigerator with a freezer has a basket for storing vaccine and freezing ice packs. With two separate compartments for vaccine storage, it maintains a temperature between 2°–8°C and freezes icepacks at a temperature range of -15° to -25°C. Its two compressors (AC or DC) have refrigerant CFC free R-134a (DC compressors are usually provided). The system allows for continuous operation of the refrigerator and freezer.
- **Photovoltaic array (solar panel):** It is fabricated with mono- or multi-crystalline silicon and has a support structure of MS galvanized or aluminum. Array structures are designed to withstand wind loads of +200 kg per square meter and have fixings for either ground or roof mounting.
- **Array-to-refrigerator cable:** To deliver the voltage, this cable connects the array (panel) to the control box of the refrigerator.
- **Charge regulator:** The charge regulator controls the charge of the battery. It has a cut-off point at low- and high-voltage and indicators for charging, under-charging, and over-charging. It also has an alarm system if the battery/module is disconnected.
- **Batteries:** Batteries store the energy transferred from the solar power. A DC compressor provides power directly to the compressor, or they provide power through the inverter for the AC compressors. A normal battery can store solar energy for five days.



How to maintain solar panel

Roof-top solar energy systems are not maintenance free!

Dirt, soot, smog, and bird droppings on the module can reduce the efficiency (output) of the solar system and make the panel output like a very cloudy day.

Steps

- Periodically inspect the solar panels—how often depends on the location—and remove any debris and dirt.
- Clean all module glass sun-surfaces with dishwashing soap to prevent any glass-shock or hard-water spots.
- Brush with a soft fiber brush to remove any bird droppings.
- Inspect modules for signs of degradation: color changes, fogged glazing, delamination, warping, or water leaks (apply sealant, if required), cracked glazing, and/or bent frames.
- Check all connections and make sure they are tight.
- Inspect exposed wiring for rodent and other damage.
- Check for rust, galvanic corrosion, and electrolysis.

Every six months, ensure that the technician checks and adjusts the tilt angle, depending on the position of the sun (lower or higher in the sky).

A solar panel module with 10 percent covered by dirt or bird dropping can reduce power output by 50 percent. A solar system produces more power on hot sunny days, compared to cloudy days.

Panels installed in dirty areas requires frequent inspection and cleaning.

Cleaning a solar panel is not for its appearance. A panel needs to be clean for it to operate at its rated capacity.

How to maintain solar batteries

Batteries are the most important component in the solar battery system.

Two types of batteries are in use:

- lead acid, long-life, deep-cycle battery
- maintenance-free sealed batteries.

Maintenance-free sealed batteries are preferred because they require minimal maintenance and are environmental friendly, compared to lead acid batteries. The average shelf life of a battery is 2–3 years and they must be replaced periodically.

Warning

Wear gloves and goggles or safety glasses when working with the batteries.

The battery acid is dangerous. Keep a box or bag of baking soda nearby to spread on battery acid spills.

Adding water to sealed batteries can destroy the battery.

Steps

- 1 Check the battery terminals and lugs periodically—at least once a week.
- 2 Apply a sealant or petroleum jelly to prevent corrosion. Apply the sealant or jelly to the terminals before assembling the battery bank. Otherwise, the sealant will not reach all the nooks and crannies, and the terminals and lugs will corrode.
- 3 Keep batteries at an even cool temperature. The idle ambient temperature for the highest efficiency is 21° to 24°C.
- 4 Check the water levels of the batteries in every cell, every six months. All the cells in the flooded batteries must be covered by water. Use distilled or de-ionized water. Do not overfill the flooded batteries.

2.4 Maintenance of Cold Chain Equipment

The maintenance rules are similar for all types of refrigeration equipment. The equipment will perform well only if it is regularly cleaned and defrosted, and safety engineering rules are observed.

2.4.1 Installation

Remember the following points when installing new or relocated equipment:

- Unpack carefully and inspect for any damage. If there is damage, notify the supplying office immediately.
- Check the data plate or the booklet enclosed to make sure that the voltage is correct (220–240V). Check also that the voltage stabilizer, if used, will provide the correct voltage.
- The correct location of equipment is important; normally, put the equipment in as cool a room as possible—with good ventilation and air circulation, and away from direct heat or sunlight. In hot climates or hot seasons, make sure the room has a fan. If two or more large refrigerators or freezers are in the room, the room should have an air-conditioner.
- In very cold climates/seasons, in certain conditions, the room may need to be heated.
- At a low space around all equipment, ensure it is at least 20cm from the wall and at least 30cm away from any other refrigerator or freezer next to it (many refrigerators and freezers give out heat at the sides and front as well as at the back).
- Ensure that nothing blocks the cover of the compressor compartment, usually located at the back or the side of the equipment.
- Stand all equipment on level wooden blocks, or on a base at least 10cm high; make sure each item is secure and cannot move or shake when in use.

IMPORTANT!

The better the conditions in which the refrigerator or freezer is working (cool, dry, and good air circulation), the longer will be the life of the equipment, especially the motor.

2.4.2 Defrosting

Frost and ice slowly build up on the surface of the freezing compartment (evaporator) when it is working. If it becomes too thick, the refrigerator compartment cannot cool efficiently. Regular defrosting is essential.

- A household refrigerator usually needs to be defrosted more often than a chest type refrigerator, but all refrigerators and all freezers and icepack freezers also need to be regularly defrosted.
- For all equipment, defrost when the frost layer reaches 5mm thick.
- If you need to defrost more than once a month, the door seal may be faulty or the door may be opened too frequently.

Procedure for defrosting:

- Remove the vaccine and store it in another working refrigerator or cold box with icepacks.
- Turn off the refrigerator and pull out the plug.
- Open the refrigerator and freezer doors.
- Remove all icepacks from the freezer.

- If a chest type, open the drain plug at the bottom.
- Put a bowl or tray in front or underneath to collect the ice and water.
- Remove loose ice by hand only; do not use tools or sharp instruments; you can reduce the melting time by putting a container with warm water (not higher than 50°C) into the freezer.
- Wipe the refrigerator dry and clean thoroughly.
- Reconnect the power and turn the refrigerator on.
- After the refrigerator is running again at the correct temperature, replace the vaccines.
- Do not remove frost or ice with a knife or any other sharp instrument; they can easily damage the refrigerator.

2.4.3 Cleaning

Refrigerators and freezers

Clean refrigerators and freezers after defrosting or every month, whichever comes first:

- Remove the vaccine and store it in another working refrigerator or cold box, including icepacks.
- Switch off the power and remove the plug.
- Wash the inside and the shelves with warm, slightly soapy water; dry carefully.
- Once a month, use a soft brush or a cloth to remove the dirt and dust from the condenser on the back of the refrigerator cabinet and the motor. (The condenser on chest-type refrigerators and freezers is often inside the wall of the unit and is not accessible).
- If you hear rattling or other noise while the refrigerator is working, check the screws holding the condenser to determine if any tubes are vibrating or touching. If it continues, call a technician.

Vaccine carriers and cold boxes

- After each working session, clean the inner surfaces of all the cold boxes
- Leave the vaccine carriers open after cleaning until they are thoroughly dry
- Inspect the inner and outer surface for cracks; mend any cracks immediately
- If the cold box is fitted with adjustable locks, adjust them so the lid fits tightly
- Protect all carriers from direct sunlight; the plastic body can warp or crack
- Handle all vaccine carriers and cold boxes with care; do not drop them

2.4.4 Safety requirements

Before you turn on any item of electrical cold chain equipment, ask a qualified electrician to check all connections, plugs, and switches. Do not make any connections, until the electrician has assured you that all the equipment is safe and operating correctly.

If you ever feel electrical shocks when touching any metal part of the cold chain equipment, or see signs of smoke or sparks coming from any electrical item, turn it off immediately, and call an electrician.

Remember to switch off and disconnect the cold chain equipment when—

- It is being cleaned, inside or outside
- Any electrical item is being replaced
- The refrigerator or freezer is being moved to another place
- Floors under or near it are being scrubbed.

If the equipment will be disconnected for more than a few minutes, consider whether any stored vaccines should be transferred to a cold box or another working refrigerator to maintain proper cold chain conditions.

IMPORTANT!

- A thick layer of ice on the evaporator surface hampers the work of the refrigerator.
- Defrost when the ice reaches 5mm thick.
- When defrosting or cleaning, put all vaccines into another refrigerator or cold box.

2.5 Control and Monitoring of Temperatures

Maintaining the required temperatures during storage and transport of vaccines is a critical task for the health worker. Temperatures must be regularly measured and recorded to ensure—

- Storage of all vaccines at the required temperature conditions
- Proper operation of the cold chain equipment

Monitoring temperatures should be a routine activity; it should be done at the start and end of the day. A number of different types of monitoring devices measure, control, and record storage temperatures.

2.5.1 Thermometers

Every piece of cold chain equipment must be fitted with a thermometer to constantly measure the internal temperature. If the refrigerator, freezer, or cold box does not have a thermometer, you will not know if the vaccine is being stored at the right temperature and is maintaining its potency. Different types of thermometers (see figure 26) are commonly used in the cold chain system to measure temperatures.

Figure 26. Common Thermometer Types

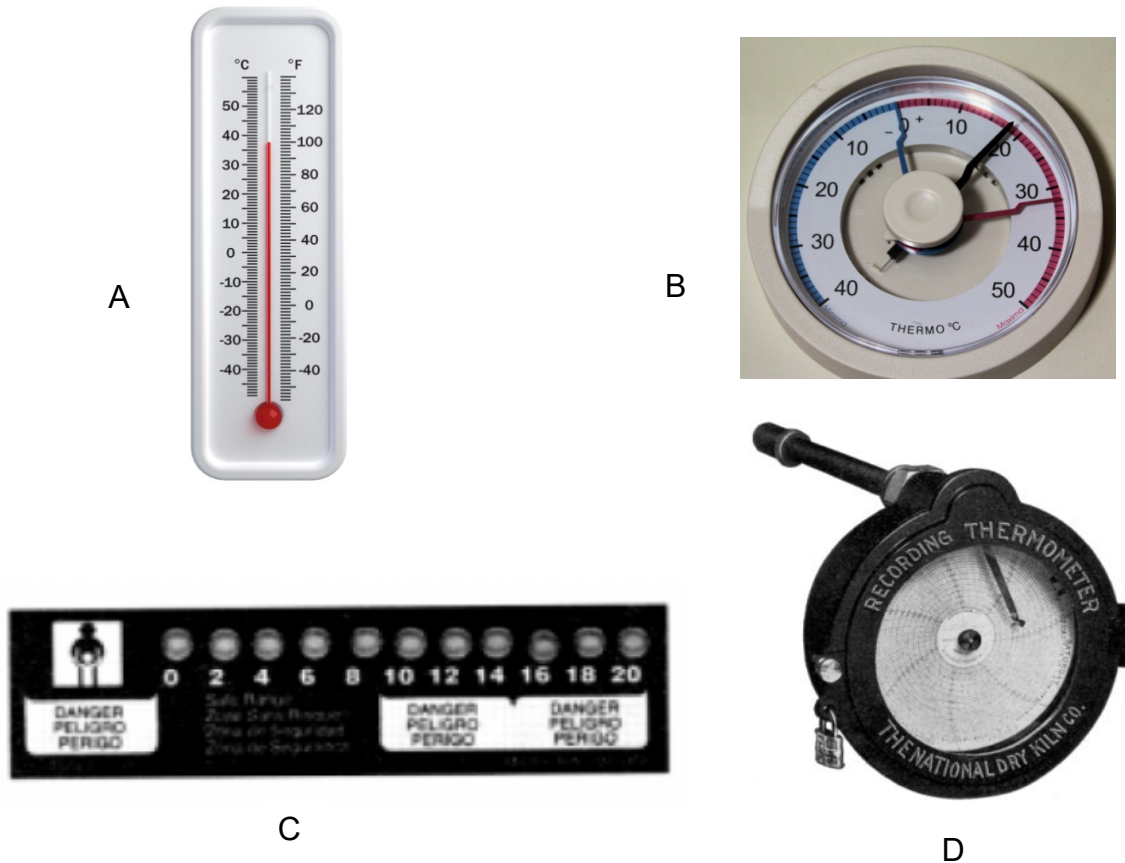

- A. Alcohol or mercury thermometer: Shows precise temperatures in the immediate area of the sensing bulb; it is recommended for use with refrigerators or freezers.
- B. Dial thermometer: Shows the current temperature; a maximum-minimum version also shows the maximum and minimum temperatures since the hands were reset; it can be used for cold rooms, ILRs, etc.
- C. Liquid-crystal thermometer: Comprises a row of temperature-sensitive indicator spots; the spot corresponding to the current temperature changes to a bright green color; it is only suitable for indicating the temperatures in cold boxes, but not refrigerators.
- D. Recording thermometer: This type records the temperature continuously on a paper chart; typically recording for seven days. These thermometers are used mainly for cold rooms and freezing rooms. Write down the date on each chart when it is fitted, and when you remove/change the chart; keep the old charts as a permanent record of store performance.

2.5.2 Temperature record sheets

- The person in charge of the cold chain equipment should read and note the temperature on the temperature record sheet twice daily: in the morning and in the afternoon. If it malfunctions, inform the supervisor. Each refrigerator/freezer must have its own temperature record sheet.

- Refrigerators/freezers must use a recommended type of thermometer placed in the middle part of the main compartment of the refrigerator or freezer.
- For ILRs, it is preferable to have two thermometers—one placed near the bottom and one near the lid (record both temperatures).
- In cold rooms and freezer rooms, use both a recording thermometer and an alcohol or mercury thermometer. Do not place the thermometer and the sensors of the recording thermometer in the airflow from the evaporator.

REMEMBER!

Keep all completed temperature record sheets in a file or safe place for future reference.

2.5.3 Refrigerator or freezer thermostats

Most refrigerators and freezers are fitted with a thermostat that controls the storage temperature. The thermostat is adjustable, so it records the correct temperature. Some thermostats have a scale or numbers on the control knob. These do not show temperature, however, but show the levels of coldness—the higher the number, the more cold, the lower the number, the less cold.

If the temperature is too low, decrease the amount of cooling—set the thermostat to a warmer setting (i.e., turn the knob counter-clockwise). Some freezers have a fast freeze switch that overrides the thermostat. Ensure that it is turned off (i.e., not lighted) if the freezer is too cold.

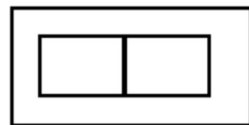
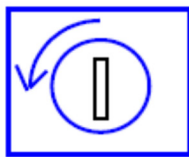

Fast freeze switch

Note, in very cold conditions—if the room temperature is below zero—adjusting the thermostat may not produce the correct storage temperature. In this case, move the vaccines or refrigerator to a warmer place.

If the temperature in the refrigerator or freezer is too high, increase the amount of cooling—set the thermostat to a colder setting (i.e., turning the knob clockwise). Vaccine freezers sometimes have a red warning control light that indicates if the temperature is above -15°C.

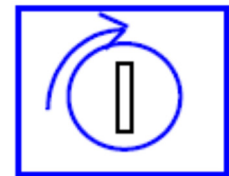

In very warm conditions—if the ambient temperature is above 40°C—you may not be able to adjust the thermostat to a maximum cooling position for a low enough temperature. In this case, move the vaccines or refrigerator to a cooler place.

If adjusting the thermostat does not produce the correct storage temperature, something may be wrong with the refrigerator/freezer, or the thermostat. You must contact the supervisor. However, before calling the supervisor, consult the faultfinding checklists in section 12.

2.5.4 Cold chain monitor card

A CCM follows the vaccines from the point of manufacturer to the end-user. Throughout, the CCM monitors the temperature and keeps a record of vaccine exposures.

Vaccines delivered through UNICEF are shipped with one CCM per 3,000 doses of vaccines. The CCM has a temperature-sensitive indicator with four windows, labeled A, B, C, and D. There are spaces to record the vaccine type, manufacturer, shipment date, dates of receipt, and dispatch, the name of health center, and the indicator readings. It also includes a table for interpreting its readings and user instructions (see Figure 27).

To activate the monitor, remove the small protective strip; the indicator will show an irreversible color change in one of the four windows if the storage temperature rises above a certain level. (For imported vaccines, the vaccine manufacturer activates the CCM.) The first three windows of the indicator—A, B, and C—will change gradually and irreversibly from white to blue when the temperature is higher than 10°C. First, A will change, then B will change, and finally C.

The A, B, and C indicators change relatively slowly; for example, at a temperature of 21°C, window A changes its color completely in two days; window B changes in six days, and window C, in 11 days.

If the temperature exceeds 34°C, window D also changes color, from white to blue.

REMEMBER!

The CCM follows the vaccine and keeps a record of its exposure to heat.

Therefore, the CCM must stay with the vaccine it arrived with.

Figure 27. Vaccine Cold Chain Monitor Card

1 **Vaccine Cold Chain Monitor**

Date in	Index	Location	Date out	Index

5 Keep the Cold Chain Monitor with your vaccine

When the Monitor arrives

- complete the top part of the card
- fill in the date
- fill in the index (–, A, B, C and/or D)
- fill in the location

When the Monitor leaves

- complete the top part of the card
- fill in the date
- fill in the index (–, A, B, C and/or D)

If windows A, B, C & D are all white use vaccines normally.

If the windows A to C are completely blue, but window D is still white it means that the vaccine has been exposed to a temperature above 10°C but below 34°C for the following number of days:

2

INDEX/INDICE 10°C 34°C

A	B	C	D
---	---	---	---

3

Polio	Use within 3 months	Use within 3 months	TEST VACCINE BEFORE USE
Measles & Yellow Fever	Use within 3 months	Use within 3 months	These vaccines may be used
DPT & BCG	Use within 3 months	Use within 3 months	
TT & DT & Hepatitis B	Use within 3 months	Use within 3 months	

6

	INDEX		
	A	AB	ABC
At a temperature of 12°C	3 days	8 days	14 days
At a temperature of 21°C	2 days	6 days	11 days

If window D is blue it means that there has been a break in the cold chain of a temperature higher than 34°C for a period of at least two hours. Check the cold chain.

The instruction "use within three months" should not be followed if either the expiry date or any local cold chain policy require a shorter period before use or disposal of the vaccine.

Assembled & distributed by Borlinger Gentschwil Switzerland

4 **SUPPLIER FOURNISSEUR**

Name: _____

Non: _____

Date of dispatch: _____

Date d'expédition: _____

Vaccine: _____

Vaccin: _____

The front of the cold chain monitor has the following:

- A record form that health workers fill in to show when they received and dispatched the vaccine shipments.
- An indicator is a heat-sensitive strip (Monitor Mark™) with four windows, marked A, B, C, and D.
- An interpretation guide explains what to do with vaccines that have been exposed to high temperatures.
- A blank space used to fill in the following information: name of supplier/manufacturer, date of dispatch, and type of vaccine. For the cold chain monitors packed with vaccines supplied by UNICEF, the manufacturer has completed this space.
- The back of the cold chain monitor has the following:
 - Instructions on how to use the monitor.
 - A table provides information on the time and temperature characteristics of the indicator (Monitor Mark™).

How to use the CCM card:

After receiving the vaccines with a CCM, on the top part of the card, enter the following:

- Date of receipt of vaccine
- Index (i.e., amount of blue) shown in the windows (A, B, C, and/or D)
- Name of the health facility

When dispatching the vaccines with a CCM, on the top part of the card, enter the following:

- Date vaccine was dispatched
- The index (i.e., amount of blue) shown in the windows (A, B, C, and/or D)

How to interpret the CCM:

- If windows A, B, C, and D are all white, use the vaccines normally.
- If windows A only, A and B, or A, B, and C are completely blue, but window D is still white, the vaccine has been exposed to a temperature above +10°C, but below 34°C for the number of days shown in table 7.
- Follow instructions on the card before using the vaccines.
- If window D is blue, there has been a break in the cold chain of a temperature higher than 34°C for at least two hours. This would indicate a serious cold chain failure has occurred; investigate immediately.

Table 7. Time-Temperature Exposure of CCM Card

	Index		
Windows completely blue	A	AB	ABC
At a temperature of 12°C	3 days	8 days	14 days
At a temperature of 21°C	2 days	6 days	11 days

REMEMBER!

Always keep the CCM together with the vaccine it came with.

Follow the manager’s instruction on what to do with the CCM after the vaccines that came with it have been used.

2.5.5 Temperature Data Logger

A temperature data logger, also called a temperature monitor, is a portable measurement instrument that can automatically record temperature over a defined time period (see figure 28).

The digital data can be retrieved, viewed, and evaluated after it is recorded. A data logger is commonly used to monitor vaccines in a cold chain during shipments, as well as during storage.

A variety of data loggers are available. Most have an internal thermo-couple, or they can be connected to external sources. Sampling and measurements are taken periodically and digitally stored. Some have a built-in display of data or out-of-tolerance warnings alarms. Data retrieval can be by cable or wireless systems, and others. They are generally small, battery-powered, portable, and have a microprocessor, internal memory for data storage, and sensors. Some data loggers interface with personal computers or smart phones for set up, control, and analysis.

Some include other sensors, such as relative humidity, wind, light, etc. Others may record input from global positioning system (GPS) devices.

Data loggers are often small enough to be placed inside an insulated shipping container or directly attached to a product inside a refrigerator truck or a cold room. They monitor the temperature of the product being shipped or stored in a warehouse. Modern digital data loggers are very portable and record the actual time and temperature. This information can be used to assess product degradation and to pinpoint the location and cause of excessive exposure.

The measured data reveals whether the vaccines in transit or during storage have been subjected to potentially damaging temperature extremes or an excessive mean kinetic temperature.

Figure 28. Temperature Data Logger



WiFi Temperature Data Logger with Alarm

2.5.6 Vaccine Vial Monitor

The VVM is a type of monitor device that the manufacturer can apply directly to each vaccine vial. It enables the health worker to verify at the time of use if the vaccine is in useable condition and has not lost its potency and efficacy from temperature exposure. The VVM progressively changes color with heat exposure; it has a visual indication when exposure has occurred. The vaccine itself, of course, does not show visible changes after heat exposure.

Note that VVMs are not a substitute for CCMs; they are an additional device to use with other monitors.

The benefits of using VVMs include—

- The health worker knows for certain that they are administering potent vaccine.
- The worker is confident that they can reuse the opened vials of vaccine; (see Policy on Vaccine Use, section 1.3.6)
- Potentially, a large decrease in vaccine wastage.

How does the VVM work?

The VVM has a heat sensitive square in a circular disk that registers a gradual and progressive color change with exposure to heat. The inner square is initially white but becomes darker with exposure to heat. If the inner square is lighter than the surrounding disk, the vaccine is safe to use. If the inner square is an equal color or darker than the surrounding disk, do not use the vaccine (see figure 29).

Figure 29. VVM

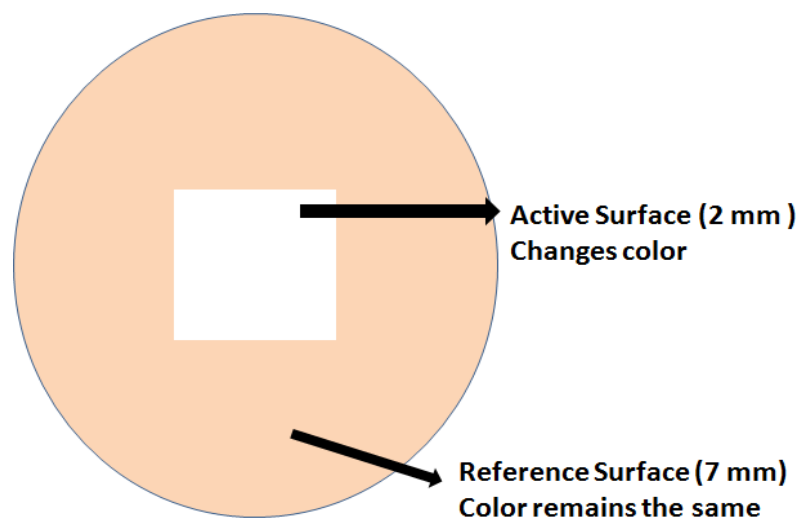
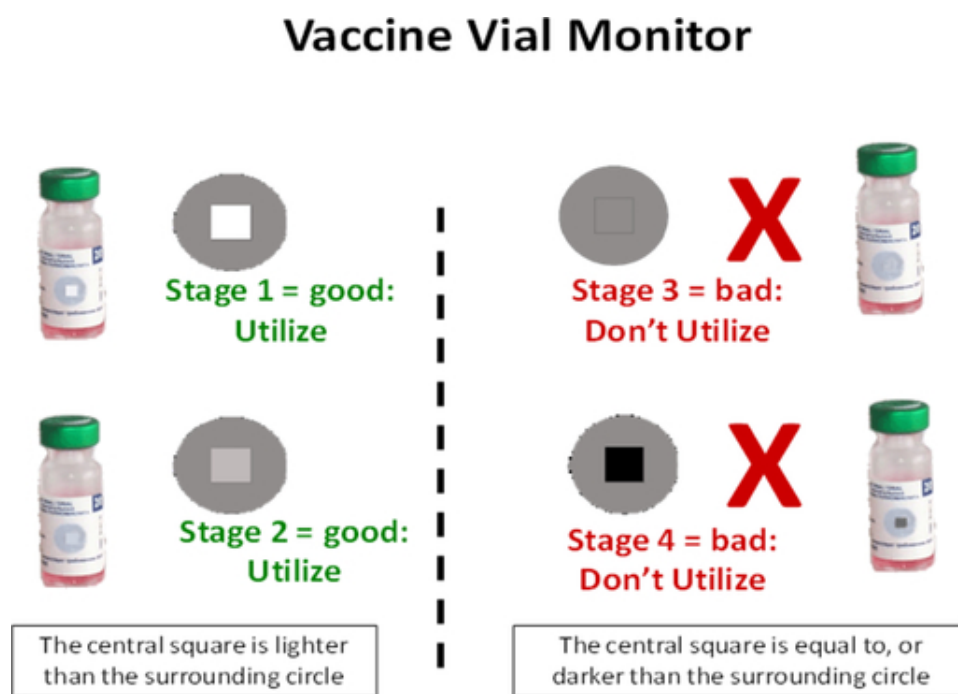

Figure 30. VVM Stages



Figure 31. How to Read the VVM



How to read the VVM:

The only important point is the color of the inner square relative to the outer circle:

- If the inner square is lighter than the outer circle, you can use the vaccine
- If the inner square is the same color or darker than the outer circle, do not use the vaccine

A glance at the monitor will show whether or not the vaccine can be used. See figures 30 and 31.

Table 8. Times Recorded for a VVM Attached to a Vial of OPV

Constant Temperature, Day and Night	Time for VVM to Reach Discard Point
At room temperature: +25°C	8 days
At room temperature: +20°C	20 days
In a refrigerator: +4°C	180 days
In a freezer: -20°C	more than 2 years

Types of VVM

Because some vaccines are more sensitive to heat than others, four different types of VVMs are available—each one matches the vaccines with different heat stability (see table 8). For example, VVM 2 is used with OPV because this is the most heat-sensitive vaccine; this VVM reaches its discard point after only 2 days at 37°C. In contrast, hepatitis B vaccine is very heat-stable and the VVM 30 is used; it takes 30 days to reach its discard point at 37°C. Table 9 describes the four VVM reaction rates by category of heat stability.

Table 9. VVM Reaction Rates by Category of Heat Stability

Category		Time to End Point at +37°C	Time to End Point at +25°C	Time to End Point at +5°C
VVM High stability	30	30 days	193 days	>4 years
VVM Medium stability	14	14 days	90 days	>3 years
VVM Moderate stability	7	7 days	45 days	>2 years
VVM Least stable	2	2 days	Not applicable	225 days

Note that vaccines made by different manufacturers may have different heat stability characteristics; WHO will assign them different VVM categories. For example, one manufacturer's BCG might use a VVM 30 while another type of BCG may need a VVM 14.

Questions and Answers on VVMs

Q: If the VVM has not reached the discard point, can the vaccine still be used if it has passed its expiry date?

A: NO.

Q: If vials have a VVM, do they still need to be kept in the cold chain?

A: YES.

Q: Should other monitors, such as the Freeze-Watch or CCM still be used?

A: YES.

Q: If the information provided by a CCM differs from the information from the VVM, which reading is the more accurate?

A: The VVM for the individual vial (see Figure 31).

Q: Is there a limit to the number of times a vial can be taken for outreach (or used in NIDs)?

A: No, if the VVM is still a safe color and the expiry date has not passed.

Q: Should vaccine with partially darkened VVM be handled differently?

A: Yes, vaccine with darker VVMs must be distributed first. The VVM enables the health worker/store keeper to select vaccines based on the most exposed vials, rather than FEFO.

How does information from a VVM correspond to that given by a CCM?

- The CCM indicates when temperature limits of the cold chain have passed.
- The VVM takes the monitoring procedure one step further and shows the impact of any such temperature changes on each individual vial of vaccine.
- The CCM monitors the vaccine's journey, while the VVM shows how each vaccine passenger has fared.

NOTE:

The VVM is not affected by freezing temperatures so it cannot give any information about freezing. If the wrapper/label is not intact, do not use the vaccine, irrespective of the VVM stage.

2.5.7 Tetanus Toxoid vaccine shipping indicators

This is another type of indicator; it travels with the vaccines from the manufacturer to the Central Store; it is included with each 3,000 doses of TT procured through UNICEF (see figure 32).

This indicator has a temperature sensitive dot that irreversibly change from silver-gray to black at temperatures above 48°C—which may be reached if vaccines are left in the sun or in poorly ventilated areas.

Figure 32. Tetanus Toxoid Shipping Indicator

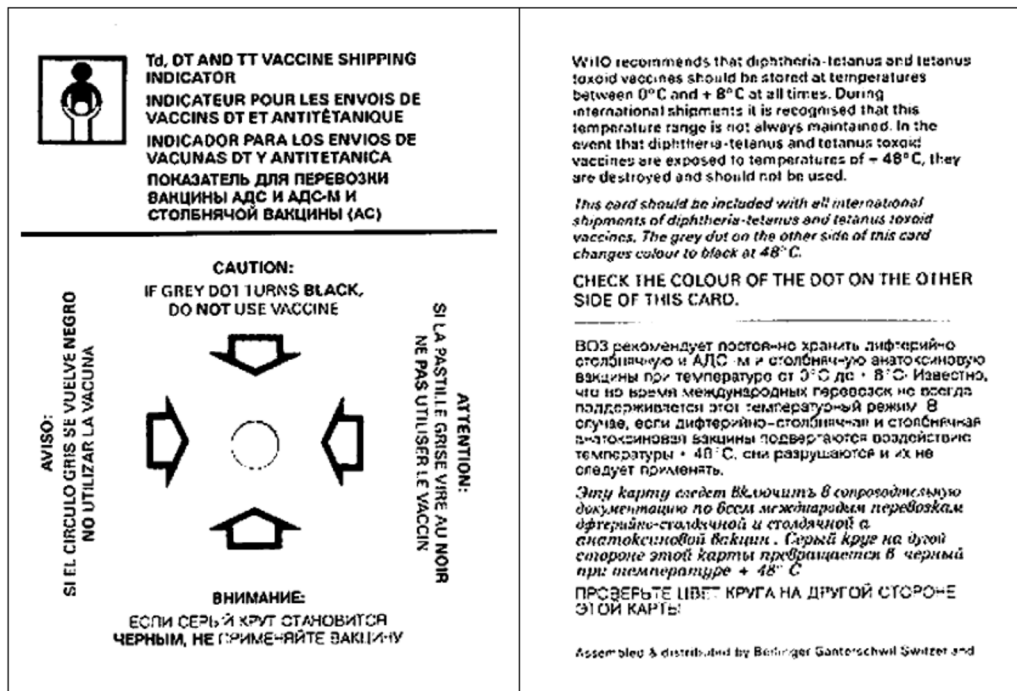

REMEMBER!

If the dot is black, do not use the vaccines.

2.5.8 Freeze-Watch indicator/Freeze-tag

The Freeze-Watch indicator, an irreversible temperature indicator, shows if vaccines have been exposed to temperatures below 0°C. A modern version, called Freeze-tag (WHO approved), is now used during transport and storage (single-use). See figure 33. It consists of a white backing card with a small vial of red liquid, all contained in a plastic casing. The indicator monitors the storage conditions of PCV13, Td, hepatitis B, and pentavalent vaccines, which lose their potency if frozen.

Figure 33. Freeze-Watch Indicators (Freeze-tag)



2.5.10 Vaccine shake test

This test is used to determine if adsorbed vaccines—Td, PCV13, pentavalent, or hepatitis B—have been frozen. After freezing, the vaccine is no longer a uniform cloudy liquid, but tends to form flakes. Sedimentation occurs faster in a vaccine vial that has been frozen than in a vaccine vial from the same manufacturer that was never frozen.

The shake test is most effective if you use a vaccine vial that you froze on purpose and do not intend to use for immunization. This vial can be the frozen control sample (see figure 34) that you compare with the suspect vaccines. If the control vial shows much faster sedimentation than the vial being tested, the vaccine in question is probably potent and can be used. If, however, the sedimentation rate is similar and contains flakes, the vial being tested should not be used. For the shake test, it is important that both the tested and control vaccine vials are produced by the same manufacturer.

Test procedure:

- Shake both vials vigorously for 10–15 seconds.
- Let vials rest for 5–10 minutes.
- Look at the vials against the light.
- Compare the vials with Figure 35. Vaccine Shake Test

Figure 34. Frozen Test Vials

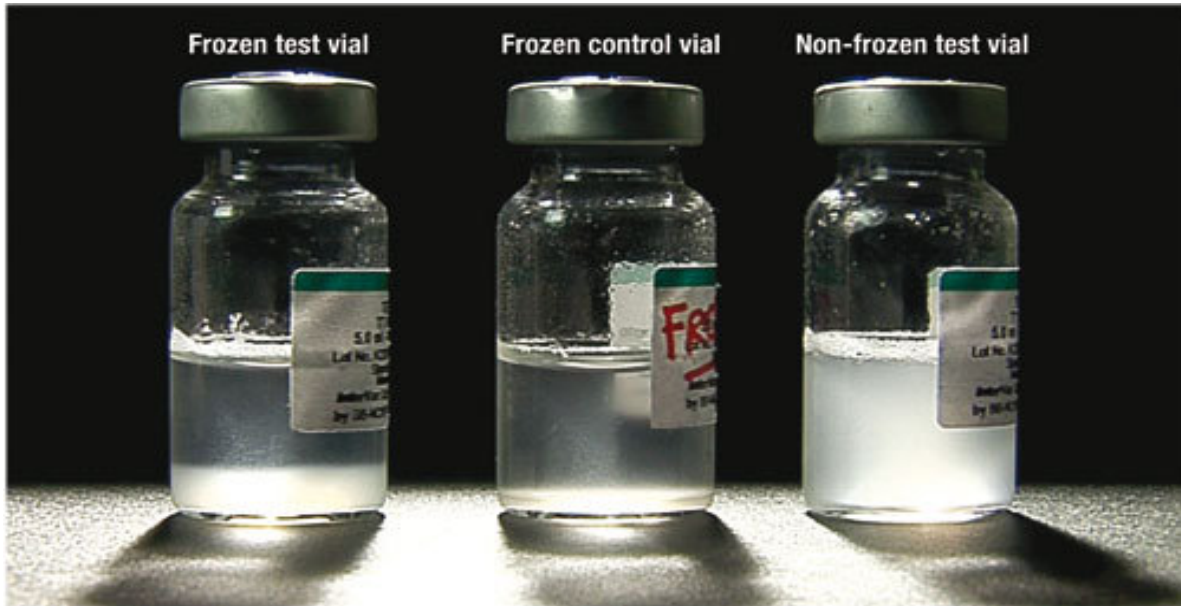
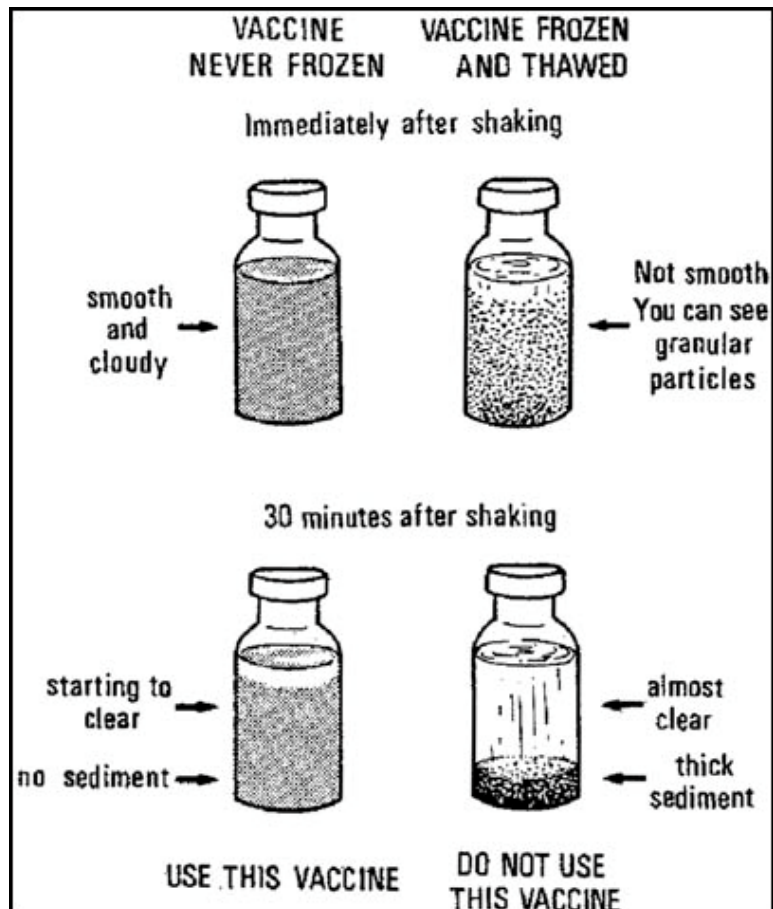
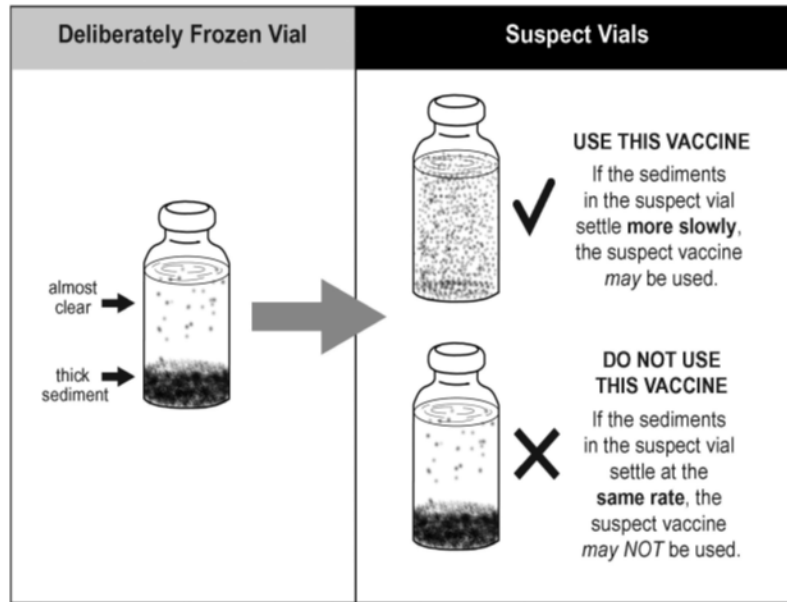

Figure 35. Vaccine Shake Test





Note:

(A) Vaccine was not frozen—use this vaccine. (B) Control vaccine was frozen and thawed—do not use this vaccine. If the vial being tested looks the same as B, do not use it!

2.6 The Cold Chain During Immunization Sessions

Maintaining the cold chain during immunization sessions is vital to ensure that potent vaccine reaches its destination—the end-user. Vaccines are most vulnerable at this level because all vials have to be opened; freeze-dried vaccines have to be reconstituted, and health staff must handle each vial carefully. Thus, the health worker conducting immunization sessions has a special responsibility to take care of the vaccines and to maintain the last and most important link of the cold chain.

The following rules will help you ensure safe vaccines and effective immunization:

2.6.1 At the beginning of the working day

- Check the ILR/refrigerator temperature; enter the details on the record sheet. If the temperature needs adjustment, take necessary steps described in section 2.5.3.
- Check the stock register and estimate how many vials of each vaccine will be needed for the planned immunization session at fixed facilities/outreach.
- Prepare a vaccine carrier for this number of vials; add enough ice-packs to last for the entire planned session. Do not work directly from the refrigerator; the door will be opened and closes too often.
- Place new, unfrozen icepacks, on their edge in the freezer for the next working day; make sure that each icepack is in contact with the evaporator.
- Take the required quantity of vaccine and diluent from the ILR/refrigerator and place them in the vaccine carrier, making sure that the diluent exactly matches the vaccine it came with (same manufacturer and delivery). If you cannot read the details of the diluent, do not use it.

2.6.2 During immunization sessions at fixed health facilities

- Take vials from the vaccine carrier and open or reconstitute them only after calling the first child for immunization.
- Remove a fresh vial from the vaccine carrier only after the previous one is empty.
- Administer the vaccine; put the vials with the remaining vaccine back into the vaccine carrier as quickly as possible; use the foam pad in the top of the vaccine carrier to keep vials you are using both cool and safely upright.
- Shake vials containing absorbed vaccines (Td) well before use.
- For measles and rubella and BCG vaccines, using the entire volume of the cooled diluent supplied when reconstituting; use only the diluent supplied by the vaccine manufacturer for use with that vaccine; ensure that it is as cool as the vaccine.
- Always keep the dropper for OPV attached to the vial. Only use the dropper supplied and the correct number of drops for that particular vaccine. Administer the vaccine orally only. Never inject OPV.
- While vaccines are outside the vaccine carrier, keep them all away from direct sunlight and other sources of heat. Avoid handling them more than is absolutely necessary.

Figure 36. Foam Pad with Vials in Top of Vaccine Carrier

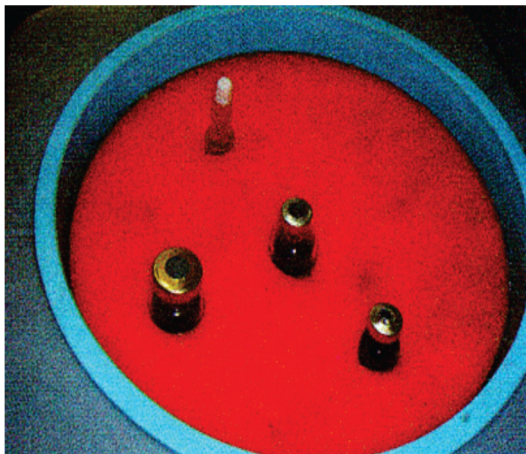

2.6.3 At the end of the working day

- Return opened vials of OPV, TT, IPV, and hepatitis B to the refrigerator for use during the next session. Discard opened vials of measles and rubella, PCV13, and BCG.
- Discard all used syringes and needles safely, in accordance with the standard operating procedure (SOPs).
- Clearly identify all unopened vials and put them back into the refrigerator; use them first during the next session. You could place them in a box or tray labeled as First Priority; it will help you remember which vials have already been outside the refrigerator.
- Record the quantity of vaccine used during the session; take stock of the quantity of each vaccine you left—remember to record this in doses.
- Check the refrigerator temperature and enter the details on the record sheet.

IMPORTANT:

Most adverse events following immunization (AEFI) are found to be related to errors in practice (i.e., errors in storage, handling, or administration of vaccines).

2.6.4 During outreach immunization sessions

Most of the points outlined above for immunization at fixed health facilities also apply during outreach immunization sessions. However, you should remember some additional points:

- Plan the session carefully; especially check that you take a sufficient stock of vaccine and diluent. You cannot easily return for more if you run out of stock.
- Take sufficient icepacks.
- For long outreach sessions where you need to travel for several days in areas where there is no electric power supply or refrigerator, take an extra cold box that contains extra icepacks. You can replace the ones in the vaccine carrier if they begin to melt, ensuring the safety of the vaccine.
- If outreach immunization sessions are outdoors, choose a cool site, shaded from the sun throughout the day, wherever possible.

SUMMARY:

- Use a vaccine carrier to hold the vials needed for each session. Do not work directly out of the refrigerator.
- Remember that vaccines are especially vulnerable at this level. Keep them between +2° and +8°C, at all times.
- During the subsequent immunization sessions, first use opened vials, or vials that have been kept outside the refrigerator.

- Do not use pentavalent vaccines if you suspect they have been frozen. Check with the shake test before using them (see section 2.4.10).
- For reconstituted vaccines, use only the diluent supplied by the vaccine manufacturer.
- Discard any reconstituted vaccine after six hours.
- Use the vials of Td and PCV13; discard IPV and hepatitis B after completing the outreach session.
- Safely dispose of all used syringes and needles.

2.7 Breakdowns and Emergencies

Any interruption to the normal functioning of cold chain equipment must be considered an emergency. The vaccine is in danger, and unless action is taken quickly, there is a risk of damage or complete loss of the vaccine stock. Emergencies in the cold chain occur mainly because of technical faults in the refrigerator, or to power failures; but, whatever the cause, they can seriously disrupt planned immunization activities. You can minimize the risks if you plan for emergencies and prepare backup plans in advance.

2.7.1 Technical faults in the refrigerator

A number of possible faults may occur in the refrigerator; some are simple and you can easily correct them; but others are more complex and require the attention of a technician. The following checklists will help you identify the main problem when a cold chain problem occurs, and they offer guidance on how the problem can be resolved. This should help minimize the risks to the vaccine stocks.

How do you know what kind of technical fault exists in the refrigerator?

There are four main symptoms of a fault:

- Refrigerator will not start; there is absolutely no cooling
- Vaccine storage temperature is too high (above +8°C)
- Vaccine storage temperature is too low (below 0°C)
- Refrigerator is working, but is making excessive noise

For each of these four main symptoms, the following checklists will help you determine what is wrong and what to do. Each checklist covers one main symptom.

How to use the checklists:

Step 1. Decide which of the four main symptoms best describes the fault.

Step 2. Turn to the appropriate checklist; read the first check question in the left column.

Answer the question with Yes or No. The arrows on the checklist show what to do next:

- If you answered Yes, this was not the fault; move down the check column to the next question
- If you answered No, you have identified a fault. Follow the arrow across to the do column, which tells you how to correct the fault

Step 3. Continue, beginning with the first question and continuing to the last.

However, before moving to the next question, make sure that the function you are checking does not have a fault. It is easy to overlook simple details when you are trying to quickly solve a cold chain failure.

Step 4. For each question, strictly follow the sequence of actions recommended. Do not jump from one check to another, this will lead to a wrong fault diagnosis.

Step 5. If you reach the last question with all Yes answers and the refrigerator is still not working properly, you may have missed some important detail. Go back to the first question and repeat the process again; this time, make sure that none of the functions you are checking has a fault.

Step 6. If, after repeating all the questions on the checklist without identifying a fault, protect the vaccine as quickly as possible:

- Transfer the vaccines to a refrigerator at 2° to +8°C, or to a cold box
- Call a cold chain technician to examine the faulty refrigerator

CHECKLIST 1:

The refrigerator will not start, and it is not cool.

CHECK	DO
1) Is the refrigerator plugged in? YES	If NO: Plug in the refrigerator.
2) Is thermostat set in operative position? YES	If NO: Set thermostat in operative position.
3) Do other electrical appliances work if connected to the refrigerator's socket? YES	If NO: Correct plug fault.
4) Has plug been fitted correctly? YES	If NO: Check wiring and socket; if possible, plug refrigerator into another socket.
5) Do you hear a click when the thermostat is set in operative position? YES	If NO: Check the thermostat.
6) Call in mechanic; refrigerator is in serious trouble.	

CHECKLIST 2:

The vaccine storage temperature is too high (above +8°C)

CHECK	DO
1) Is control set at correct temperature? YES	If NO: Set thermostat control at cooler temperature.
2) Are evaporator walls free from snow layer? YES	If NO: Turn off refrigerator and defrost.
3) Is refrigerator door tightly closed? YES	If NO: Check seal; adjust hinges and lock.
4) Is air circulating freely inside and outside refrigerator? YES	If NO: Install and load refrigerator properly.
5) Is condenser clean? YES	If NO: Clean condenser using brush or vacuum.
6. Is thermostat working properly? YES	If NO: Close circuit without using thermostat.
7. Call in mechanic/technician.	

CHECKLIST 3:

The vaccine storage temperature is too low (below 0°C).

CHECK	DO
1) Is thermostat control set at the correct temperature? YES	If NO: Set thermostat control at warmer temperature.
2) Call in mechanic/technician.	

CHECKLIST 4:

The refrigerator is working but is making excessive noise.

CHECK	DO
1) Do you hear foreign noises?	If YES: Shake refrigerator carefully. If it is insecure, stand it evenly, using wooden blocks. If noise continues, check metal parts on back of the cabinet.
2) If trouble continues, call a mechanic/technician.	

2.7.2 Plan for cold chain emergencies

Emergencies will happen from time to time. Be prepared for an emergency before it happens. To ensure the cold chain is maintained for each vaccine storage point and for vaccines during transportation, prepare an emergency plan. The person responsible for the storage or transportation arrangements should prepare the plan, and have their supervisor approve the plan.

The plan should include—

- How can the vaccines be protected?
- How can the faults be corrected as quickly as possible?

Important points to remember during any cold chain emergency:

- Keep all refrigerators, freezers, and cold boxes closed, as much as possible. Open them only when absolutely essential, and work as quickly as possible.
- Vaccines in freezers are usually safe for up to 24 hours or until any icepacks or ice has melted.
- Vaccines in ILR or freezers will be safe for much longer, depending on which model is used; they can be protected for up to 48 hours.

2.7.2.1 Sample plan of emergency measures

A. General

Objectives of an immunization program emergency plan

- Keep the vaccines safe.
- Continue the immunization activities.

Principles

- Be prepared for emergencies.
- If an emergency happens, know what to do and who should do it.
- Always have at least two people who know what to do and when.
- Improve future preparedness by learning from experience.

Possible Emergencies	Questions/Issues
* Electrical power cut - for short length of time - for a long length of time	* What type of refrigerator/freezer? * How many hours protection can each type give? * When and where to move vaccines? * Need and availability of icepacks/cold boxes?
* Refrigerator breakdown - minor repairs needed - serious repairs needed	* Location of other vaccine storage equipment? * Checklist for initial diagnosis? (See section 2.6.1)
* Delay in vaccine arrival	* Reserve stocks? - at the facility - at higher level - elsewhere in the area * Planned rescheduling of immunization?
* Transport breakdown	* How long is cold life of boxes? * Alternative refrigerator storage or ice supply along the route?
* Loss of vaccine potency (cold chain failure)	* Reserve stocks at higher level? * Temperature records/monitor cards to help investigation?
* Epidemic—sudden need for control immunization	* Reserve stocks at the facility or higher level of vaccine syringes and needles? * Sufficient refrigerator capacity, cold boxes, and icepacks? * Transport and fuel available?
* AEFI	* Investigation forms? * Procedures for handling suspect case and vaccine?

B. Specific aspects of emergency plan for polio NIDs

Each location that stores vaccines; but, particularly the provincial and district, should have its own written emergency plan.

Each local plan should include the following information:

- How many hours can each type of refrigerator or freezer keep a safe temperature if electricity fails, assuming it is not opened? This will vary according to the season of the year, of course, but guideline figures for the hottest season are as follows:

Regional: Large horizontal refrigerator (MK 302) * 48 hours

(*assuming a full set of water packs is installed inside)

Large horizontal freezer (HF 5506) 20 hours

Medium horizontal freezer (SB 300) 20 hours

District/health facility: Vertical household refrigerator 2–3 hours

A cool, well-ventilated room for the equipment is best.

- Who keeps a spare key for the vaccine storeroom, and who is responsible if the designated cold chain person is absent?
- Where are the nearest, suitable refrigerators/freezers if vaccines must be moved; what is the name and telephone number of the contact person if the refrigerators/freezers are in another building or institution?
- How many and what type of cold boxes are to be kept available in case vaccines have to be moved; what is the minimum number of frozen icepacks that must always be available to put in the cold box.

Note: CCM cards stored with the vaccine must be moved with the vaccine if the vaccine is moved to another refrigerator or freezer, or to a cold box, even temporarily; the top part of the card must be filled in.

- How long must a cold box keep vaccines at a safe temperature (below +10°C) without changing ice or icepacks and without opening it (the cold life of the box)? This also depends on outside temperature and, of course, on the number of frozen icepacks and the thickness of the insulated wall of the box. Guideline figures for the hottest time of year are as follows:
 - Large cold box (20 liters vaccine capacity):
 - with maximum number of frozen icepacks (30): 84 hours
 - Small cold box (4.5 liters vaccine capacity):
 - with maximum number of frozen icepacks (9): 50 hours.

2. Where is the reserve drum/container of gasoline in case it is urgently needed?



3. Non-Vaccine Items Storage and Disposal of Unusable

No	Description	National		Provincial/Regional		District	Tehsil	EPI Center
		Policy	Operations	Policy	Operations			
3.1	INJECTION EQUIPMENT	✓	✓	✓	✓	✓	✓	✓
3.1.1	Disposable syringes and needles				✓	✓	✓	✓
3.1.2	Single-use syringes (auto-destruct system)		✓		✓	✓	✓	✓
3.1.3	Jet injector gun							
3.2	SAFETY BOX		✓		✓	✓	✓	✓
3.3	STORAGE OF NON-VACCINE ITEMS							
3.3.1	Storing diluents, syringes, and safety boxes	✓	✓	✓	✓	✓	✓	✓
3.3.2	Storing expired or damaged vaccines, diluents, and syringes	✓	✓	✓	✓	✓	✓	✓
3.3.3	Storing spare parts, stationary, and other items	✓	✓	✓	✓	✓	✓	✓
3.3.4	Equipment used for stacking and placing	✓	✓	✓	✓	✓	✓	✓
3.4	DISPOSAL OF UNUSABLES	✓	✓	✓	✓	✓	✓	✓
3.4.1	Safe disposal of expired or damaged vaccines and diluents	✓	✓	✓	✓	✓	✓	✓
3.4.2	Final disposal procedures	✓	✓	✓	✓	✓	✓	✓
3.4.3	Methods of safe disposal	✓	✓	✓	✓	✓	✓	✓

Ensuring safe immunizations extends all the way to the place and time that the vaccine is administered during an immunization session. Correct use and care of injection equipment is, therefore, just as important as safe vaccine handling and maintaining the cold chain.

3.1 Injection equipment

Injection equipment can be divided into three categories:

4. disposable syringes and needles
5. single-use syringes (the auto-destruct system)

3.1.1 Disposable syringes and needles

Disposable syringes are sterilized during manufacture, then packed; they are sterile until the expiry date on the packet (see figure 37). Because disposable syringes are for single-use only; they must be disposed of safely after use. The most effective way to dispose of used injection equipment is to burn it at a high temperature; this will prevent reuse and avoid injuries to staff and harm to the environment.

Figure 37. Disposable Syringes and Needles



3.1.2 Single-use syringes (auto-destruct system)

Single-use auto-destruct syringes have a special mechanism that locks the piston after one movement and, automatically, prevents reuse (see figure 38). They are available in 0.5 ml and 0.05 ml sizes to accommodate all EPI.

During production, the needle is joined to the syringe; they are sterilized together and packed individually.

This type of syringe presents the lowest risk of person to person transmission of blood borne pathogens because it cannot be reused. The auto destruct syringe is the preferred type of disposable equipment for administering vaccines, and it is preferred for conducting mass immunization campaigns.

Figure 38. Auto-Destruct Syringe



3.2 Safety Box

Sharps containers (or safety boxes) safely hold items that could injure a service provider or waste handler before final disposal (e.g., used needles, syringe/needle combinations, and scalpel blades, or broken vials/ampoules). Sharps boxes, made of plastic or cardboard, are coated with a plastic film strong enough to protect waste handlers from injury—they are puncture and leak resistant (see figure 39). They typically have an opening large enough to insert sharps but small enough to prevent those already in the container from accidentally falling out. Most sharps boxes have sealable tops that cannot be opened after they are sealed. The boxes come in a variety of sizes—small one-liter boxes to boxes that can hold many liters of sharps waste. The size is usually determined by the amount of sharps waste at the point of generation and the frequency with which it is replaced.

Safety boxes should be filled only once. When the box is three-fourths full, it should be sealed, then immediately destroyed. Never place vials, ampoules, or needle caps in the safety box.

When they are used consistently and correctly, safety boxes can help prevent disease-spreading needle-stick injuries.

Different safety boxes are assembled in different ways, but appropriate instructions are usually printed on each box. Health workers should practice assembling and using safety boxes.

Figure 39. Safety Box

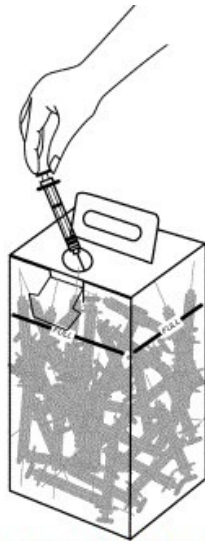

UNSAFE: Box is too full to use safely (the health worker could be pricked by one of the needles already in the box).



3.3 Storage of Non-Vaccine Items

Diluents, syringes, safety boxes, and spare parts for cold chain equipment maintenance and other immunization supplies must be stored correctly in the dry stores. See figure 40.

Diluents, syringes, and safety boxes are supplied in cardboard cartons. Stack them on pallets and place them on racks in the dry storage area.

Figure 40. Pallet Racking System at Warehouse



3.3.1 Storing diluents, syringes, and safety boxes

- Stack all diluents, syringes, and safety boxes on pallets in the pre-assigned pallet bays.
- Stack diluents by batch number and expiry date. Clearly label the cartons to show the name of the vaccine with which the diluent was supplied and the manufacturer, presentation, batch number, and expiry date.
- Stack syringes by type and expiry date. Clearly label the cartons to show syringe type, syringe capacity, syringe manufacturer, and expiry date.
- Stack safety boxes by arrival date and by size to ensure they are distributed on a first expiry, first-out (FEFO) basis. Clearly label the safety boxes by size (e.g., 5 liters).

3.3.2 Storing expired or damaged vaccines, diluents, and syringes

- a. Assign a separate, well-ventilated room for these products. Clearly mark the assigned storage bay(s): PRODUCTS FOR DISPOSAL so that items placed here are not confused with usable stock.
- b. Store products until they can be removed from the store for final disposal.

3.3.3 Storing spare parts, stationary, and other items

- a. Store these products on shelves in a locked room.
- b. Label the products by type.
- c. Distribute products, as needed.
- d. To avoid stock outs, immediately replace the stock.
- e. If spare parts for cold chain equipment maintenance are needed, the sub-engineer must request the replacement items.

3.3.4 Equipment used for stacking and placing

3.3.4.1 Pallets

A pallet is the structural foundation of a unit load that allows handling and storage efficiencies. Goods or shipping containers are often placed on a pallet and secured with strapping, stretch-wrap or shrink-wrap, and shipped. Wooden, plastic, and steel pallets are used for different purposes (see figure 41).

Figure 41. Pallets

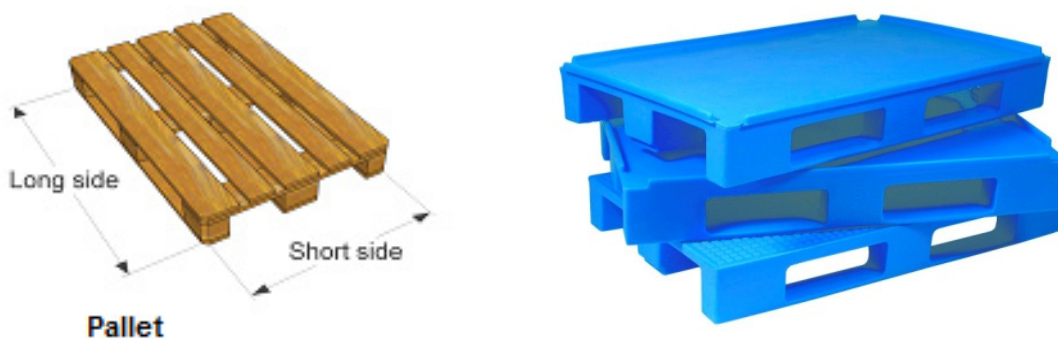

3.3.4.2 Trolleys

Pallet hand trolleys, suitable for horizontal pallet transport, are used for lifting and moving pallets in the aisles and lower racks.

Flatbed trolleys, a common form of transport in warehousing and distribution environments, are used to move bulk loads. It's very simple design has a basic flat platform with four wheels and a fixed handle that can either push or pull the platform, with the load on the platform (see figure 42).

3.3.4.3 Fork lifters

A forklift truck—also called a lift truck, a fork truck, or a forklift—is a powered industrial truck used to lift and move materials short distances. Forklifts are a critical part of warehouses and distribution centers. For drive-in/drive-through racking, a forklift needs to travel inside a storage bay, which is multiple-pallet positions deep, to place or retrieve a pallet. Often, forklift drivers are guided into the bay through guide rails on the floor and the pallet is placed on cantilevered arms or rails. High-reach forklifts are used for stacking and lifting pallets on higher racks.

Figure 42. Trolleys



3.4 Disposal of Unusables

A fundamental objective of supply chain management is to eliminate the vaccine wastage during storage. However, sometimes vaccine has been damaged or has exceeded its expiry date. When this occurs, the affected vaccine and any associated diluents must be clearly identified and isolated from other vaccines and diluents. Correct procedures must then be followed to account for the loss of the vaccines and to ensure they are disposed of safely.

The main reasons for vaccines becoming unusable are—

- expired vaccines and diluents
- damaged vaccines and diluents
 - a. physical damage
 - b. heat exposure (VVM color change)
 - c. exposure to freezing.

In addition to the reasons listed above, some other reasons may cause wastage/expiry of vaccines.

Relevancy

Vaccines supplies are not relevant to the needs of the clients.

Quality

The quality of vaccines sometimes does not comply with the standards.

Quantity

Sometimes, the quantity procured is in excess of the needs because of the unrealistic forecasting and other factors, and it could not be consumed before expiration.

Improper handling

In storage environment or conditions, careless handling at various levels of storage, distribution, and transportation may cause damage.

3.4.1 Safe disposal of expired or damaged vaccines and diluents

3.4.1.1 In-Date and Useful Vaccines

For near-expiry vaccines, with 25 percent of shelf life left, identify them on a list and circulated the list to all the entities that could use them before the expiry date.

3.4.1.2 Managing expired vaccines and diluents

- a. Use the expired items report or stock control system to identify the items.
- b. Locate the items. Place them in a container clearly marked: EXPIRED VACCINE FOR DISPOSAL—DO NOT USE. Store the container in a cold room or vaccine refrigerator until you have permission to remove them from the cold chain.

- c. If diluents also need to be removed from stock, place them in a container clearly marked EXPIRED DILUENT FOR DISPOSAL—DO NOT USE. Store the container in a safe place in the dry store.
- d. Record the expired vaccine and/or diluents in the stock control system. Prepare a Loss and Adjustment Report.
- e. As soon as you have permission to dispose of the vaccine, move the container to a safe place outside the cold chain.

3.4.1.3 Managing physically damaged vaccines and diluents

It is unlikely that vaccine vials will suffer from physical damage because glass vials are very robust. However, if you drop an ampoule of vaccine and diluents, it can easily break. If an ampoule breaks, put on protective gloves and proceed as follows:

- a. Write down the number and type of broken vials or ampoules and the batch number(s) and put them to one side.
- b. If vials or ampoules are contaminated with spilled vaccine, write down the number and the type affected. Place the broken and contaminated vials or ampoules in a closed leak-proof plastic container; clean up the contents with disinfectant.
- c. If vaccine spills, carefully collect all broken glass and clean the spillage area with disinfectant.
- d. Clearly mark the container: DAMAGED VACCINE FOR DISPOSAL—DO NOT USE; store it in a safe place outside the cold chain.
- e. Record the breakages in the stock control system.

3.4.1.4 Managing damaged vaccines due to heat exposure (VVM color change)

If the VVM shows that vaccine has reached the discard point, proceed as follows:

- a. Write down the number and type of damaged vials and their batch numbers; place them in a closed plastic container or carton.
- b. Clearly mark the container: DAMAGED VACCINE FOR DISPOSAL—DO NOT USE; store it in a cold room or vaccine refrigerator until you have permission to take it out of the cold chain.
- c. Record the damaged vaccine in the stock control system and prepare a Loss and adjustment report.
- d. As soon as you have permission to dispose of the vaccine, move the container to a safe place outside the cold chain.

3.4.1.5 Managing damaged vaccines due to exposure to freezing

If you suspect that vaccine has been frozen, you must carry out the Shake Test, as described in EVM-SOP-E8-01²—When and how to conduct the Shake Test. If you discover freeze-damaged vaccine, proceed as follows:

² A WHO document that explains effective vaccine management standard operating procedures.

- a. Write down the number and type of damaged vials and their batch numbers; place them in a closed plastic container or carton.
- b. Clearly mark the container: **DAMAGED VACCINE FOR DISPOSAL—DO NOT USE.** Store the container in a cold room or vaccine refrigerator until you have permission to take it out of the cold chain.
- c. Record the damaged vaccine in the stock control system; prepare a Loss and adjustment report.
- d. As soon as you have permission to dispose of the vaccine, move the container to a safe place outside the cold chain.

3.4.2 Final disposal procedures

- a. Obtain approval for disposal.
- b. Complete the final disposal.

Healthcare waste must, ultimately, be treated and disposed of in a way that is regulated by the law. When laws include the following provisions—

- Dispose of non-hazardous waste either by incineration or disposal in a landfill. Usually, special arrangements are not required to treat this type of waste.
- Hazardous/infectious waste must be disinfected and buried, incinerated, or disposed of by specific procedures, such as with chemicals. To dispose of carcinogenic materials, follow the established procedures or WHO recommendations.
- Immediately contain sharps waste, then incinerate—if the incineration temperature is 900°C or high enough to disfigure and melt the sharps—bury (preferably in a sharps pit), or isolate in a sharps barrel.

3.4.2.1 National FDI policy recommendation on injection/sharp waste disposal

For collection and disposal of used syringes, needles, and other injection materials, use safety boxes for all immunization activities (GOP 2022).

Disposal of injection waste at immunization site:

Dispose of sharp wastes—such as used syringes and its parts and needles—in the safety box immediately after use. Collect other wastes—such as empty vial/ampoule, blister pack, cotton, etc.—in a separate bag/container in the immunization sites. Return safety boxes and other waste bags to the nearest health facility for storage at a secured place for future reuse (if partially filled) or for final disposal.

Final disposal of injection waste:

Auto combustion type of incinerators—with temperatures in excess of 800°C—are preferred to destroy all contaminated sharp wastes, including syringes and needles used for immunizations. This equipment ensures the most complete destruction of sharp wastes and also reduces environmental pollution. However, for limited resources and low levels of immunization activities waste disposal, you can use the following:

- Facilities that are remote and cannot transport immunization waste to a facility with an incinerator should store filled safety boxes and other waste bags in a secured place in the health facility. Burn all filled safety boxes in a pit prepared for the purpose. The pit must be in a secluded area, out of the reach of children and domestic animals, but within the health facility premises. After burning, cover any leftover residue with a thin layer of earth.
- If the facility without an incinerator is located near a facility with an incinerator, transport the waste to the facility with the incinerator.
- Incineration of the injection waste is recommended if a standard incinerator is available.
- For either pit burning or incineration, always ensure it is directly supervised by a responsible officer.
- The District Health Officer (DHO)/ Executive District Officer (EDO) (H)/ Chief Executive Officer (CEO) is responsible for providing instructions for disposal of injection waste according to local arrangements, in accordance with the National Injection Safety Policy.

3.4.3 Methods of safe disposal

3.4.3.1 Landfill/Burial

Landfill is the oldest and the most widely practiced method of disposing of solid waste (see figure 43). An appropriate landfill has an excavated pit away from water courses and above the water table. Do not use uncontrolled dumping, which is harmful for the environment and, potentially, dangerous for people and animals. Immediately use the fresh municipal waste at the base of working face to cover the materials disposed of at a landfill.

Figure 43. Landfill Disposal



3.4.3.5 Medium temperature incineration

Properly designed, small-scale incinerators are a reasonable option for treatment and disposal of healthcare waste at health centers and health posts. Sufficiently high temperatures can be reached when the correct design specifications for a double-chamber combustion burner are followed (see figure 44). Furthermore, the double-chamber design helps ensure that toxic emissions are minimized, and that incinerator operators and nearby communities have minimal impact from incinerator emissions. A two-chambered incinerator operates at a minimum temperature of 850°C, with a combustion retention time of at least 2 seconds in the second chamber. The De Montfort incinerator, a classic example of a double-chamber small-scale incinerator, has been constructed in many rural areas around the world.

Do not use open burning at low temperatures, particularly for medicines and similar materials because it will release aerosol forms into the open air. Low-temperature burning will not completely destroy the sharps waste, plus it exposes personnel and the surrounding community to toxic gasses from the burning plastic. Low-temperature burning of expired medicines may release toxic or carcinogenic compounds into the air.

Figure 44. Incinerators



3.4.3.6 High-temperature incineration

Some industries have furnaces that operate at above 850°C, with long combustion retention time; they also disburse exhaust gases via tall chimneys to a high altitude. When selecting this method, remember that it may not be cost effective. A rule of thumb could be that no more than 5 percent of the value of the commodities should be used as fuel in these furnaces.

3.4.3.8 Sharps pit

Improper disposal of sharps waste poses a high risk of disease transmission for healthcare workers, waste workers, and the general public.

Sharps are often collected in cardboard safety boxes and burned in small incinerators. Several non-burn methods have been developed in response to concerns about air pollution and the short lifespan of brick incinerators (WHO 2005a; PATH 2007). The methods usually include the following steps:

- Use onsite mechanical needle cutters or electric needle destroyers.
- Shred the treated plastic parts.
- Bury the metal pieces in sharps pits.
- Re-melt the plastics for recycling.

Alternatively, the sharps waste can be autoclaved, shredded, and then encapsulated in cement blocks; the result can be useful items, such as hospital benches.

In facilities where burning devices cannot reach high temperatures, or where transport of the safety boxes to a treatment facility is not an option, used needles can be safely disposed of with needle removers and sharps pits. Protected sharps pits (see figure 45) are constructed on-site, set in the ground, and designated for disposal of sharps only—no injection devices, such as used syringes. Locate them away from ground water sources; the bottom of the pit should be above the water table, and usually lined with concrete or brick. Extend an approximately 1 meter-long chute from the top of the pit; include a lid that will prevent water from entering. Fence in the entire structure to prevent unauthorized entry.

Figure 45. Sharps Pit

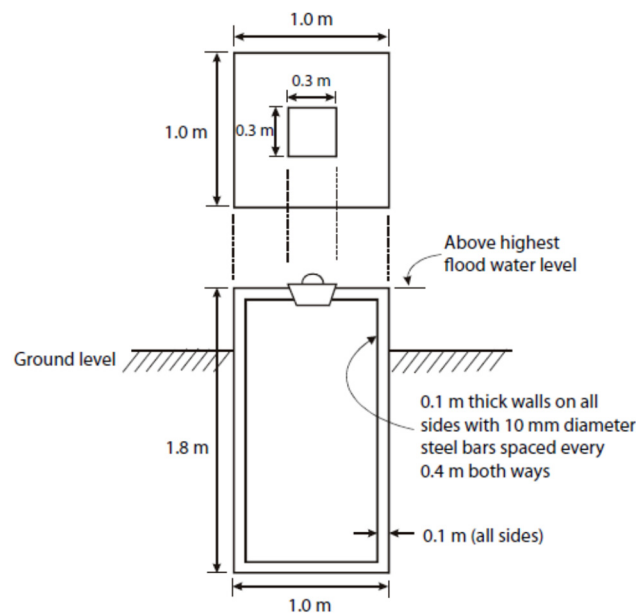



4. Vaccines Logistics Management Information System

No	Description	National		Provincial/Regional		District	Tehsil	EPI Center
		Policy	Operations	Policy	Operations			
4.1	INTRODUCTION	✓	✓	✓	✓	✓	✓	✓
4.2	TYPES OF RECORDS					✓		✓
	Forms					✓		✓
4.3	STRUCTURE OF THE WEB-BASED LMIS, ITS PROCESS AND USE					✓		✓
4.3.1	Features					✓		✓
	Users					✓		✓
4.3.2	Homepage					✓		✓
4.3.3	User login					✓		✓
4.4	COMPUTER SYSTEMS					✓		✓
4.4.1	Associated materials and equipment					✓		✓
4.4.2	Instructions for data entry operators					✓		✓

4.1 Introduction

An uninterrupted supply of vaccines is a pre-requisite and a challenge for national immunization programs. Designing an effective and sustainable supply chain system for vaccines and other drugs is important and can be complex. A correctly run supply chain system should keep vaccines in good condition, rationalize vaccines storage points, use transport as efficiently as possible, reduce wastage, and provide information for forecasting needs. This requires a good management of the system, with a simple, but well-designed, information system in place.

The web-based vLMIS replaces the current manual vaccine logistics record keeping system; The new system helps plan and manage the immunization resources and ensures that adequate quantities of vaccines are always available to meet demand at the right time, to the right place, in the right condition, in the right amount—no matter where the end-user lives.

The vLMIS is easy to use; it brings in district- and union–council-level reporting by aggregating EPI facility-level data through paper-based reports. With a unified system for reporting and requisitioning, the vLMIS system integrates information from all levels. To access the web-based vLMIS, go to <http://vlmis.gov.pk>.

4.2 Types of Records

From a logistics point of view, only four activities are usually carried out—commodities are purchased, stored, moved (in transit), or consumed (used). The following types of records are needed to track the supplies (see figure 46).

Stock keeping records: Keep information about products in storage.

Transaction records: Keep information about products being moved.

Consumption records: Keep information about products being consumed.

Each record type has a specific recording form and use.

Stock keeping Records

- Stock keeping records are used to record information about items in the store. It must contain the record on quantity of stock on hand and the quantity of losses and adjustments.
- The warehouse manager and other warehouse staff—service delivery point staff who receive or issue stock from storage and the staff who do the physical inventory of the stock—complete the form.
- Entries are recorded on the stock keeping record whenever vaccines are received or issued. Entries are also recorded when stock is counted during a physical inventory. When the stock keeping record does not have space for further entries, start a new record using the ending balance from the previous record.
- Stock keeping records are organized by date. They record receipts, issues, losses, and adjustments; and the balance on hand. They also record the results of physical inventories—when items are counted to verify the quantity in storage.
- The most common format for stock keeping records are individual stock registers and/or ledgers.
- A stock card is a generic name for either an inventory control card or bin card. A bin card is an individual stock keeping card that keeps information about a single lot of a product, by type.

Figure 46. Vaccine Supply Chain

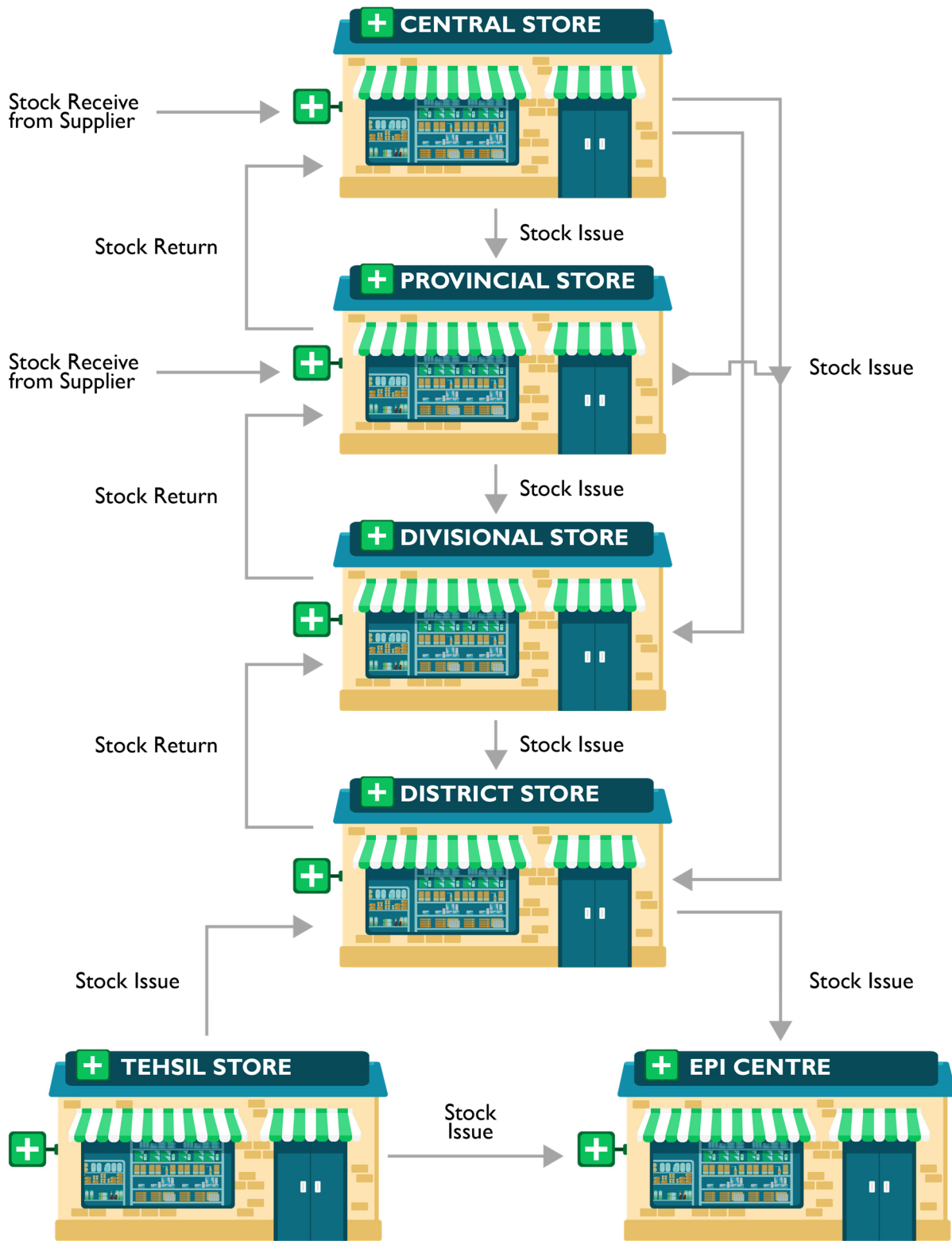

Stock Register

The basic stock keeping record is the stock register. It provides an up-to-date record of all transactions of vaccines received, issued, and discarded at the warehouse/store. The store keeper maintains the stock register; the store-in-charge/logistics manager at each level must verify the entries.

Write only the name of the warehouse/store on the cover page of the register.

The officer-in-charge must certify the stock register, as mentioned above; the specimen of the certificate is as under—

“It is certified that this register is maintained for commodities of the _____ facility, contains _____ pages (from Page No. _____ to Page No. _____)”. All the pages have been checked and found intact, accurate, duly stamped and initial by the undersigned.

Seal & Signatures

Date: Officer-in-charge

Index of Contents

An Index of Content, which serves as a quick reference guide, is inserted at the front of the stock register. In the index, the page numbers of the stock register, which are assigned to the specific items, are listed against each item's name. Each vaccine is listed on a separate page. Reserve a sufficient number of pages in the stock register for each vaccine.

Example No. 1 of the Stock Register

The transaction of OPV is recorded on page no. 5 of the stock register. In the index, 5 is written in the column as the page number, against which OPV will be recorded.

Example No. 2 of the Stock Register

The transaction of the measles and rubella vaccine is recorded on page no. 12 of the stock register. In the index, 12 is written in the column as the page number, against which the measles and rubella vaccine entries will be recorded.

Example of Stock Register Entries

INDEX

S. No.	Name Item/Article	Page No.
1.	OPV	5
2.	Measles and rubella vaccine	12
3.		22
4.		27
5.		45

How to Record Information in the Stock Register

Name of Item/Article (top of the page)

The name of the item, with the specifications, is written as shown in the example below. Generic names, not brand names must be written; however, you can mention the brand names in the description column (column no. 2 of the stock register).

Unit

The unit, the basic accounting unit, is the number of doses in the vial (standard packing) for a vaccine; remember, all supplies must be requested, issued, and reported by number of doses.

Date (column no.1)

Write the date of the transaction (issue/receipt) in this column.

Received From/Issued to and Reference (column no. 2)

This column identifies the source of any quantity that is received and the consignee to whom any quantity has been issued from the warehouse/store. Use different colored ink for quantities received and issued: preferably red for receipt and blue for issues.

Received (column no. 3)

In this column, record the quantity of the item received.

Issued (columns no. 4 and 5)

For care: In this column, record the quantity of the item issued for use or for onward distribution to the lower levels.

Discarded

In this column, record the quantity of the expired/damaged/broken/unusable item. The store keeper must certify entries and the officer-in-charge must countersign.

Balance (column no. 6)

In this column, record the balance quantity of items available in the warehouse/store after receipt or issuance.

Name and signature (column no. 7)

In this column, the store keeper must sign and the officer-in-charge must initial against each transaction.

Remarks (column 8)

In this column, write remarks—expiry date/expired quantities of the item, physical condition, or information about any unusual condition or specific situation.

Note: When the page is full and no other entries can be made, on the bottom of the same page—in red ink—write the next allotted page number of the stock register; use, for example, Balance Carried Forward to page number.... On the next page of the stock register for the item being carried forward, start by referencing the previous page number (e.g., Balance

Brought Forward from page number.... If the stock register is complete, write the following statement:

*Balance Carried forward to Stock Register Volume no.....page no.

*New Stock Register must contain the following statement at the start of every page: “Balance Brought Forward from Stock Register Volume no..... page no....”

Sample entries in the stock register

Page No. 5

Vaccines

Name of Item/Article: OPV Unit: Doses

1	2	3	4	5	6	7	8	9
Date	Received From/ Issued to and Reference	QUANTITY IN UNITS				Name & Signature	Voucher No.	Remarks
		Received	Issued		Balance			
			Vaccinated	Wastage				

Transaction Records

Transaction records are used to record information about the movement of stock from one storage facility to another. It is frequently desirable to include the current stock on hand; as well as losses, adjustments, and consumption data. The issuing facility can use the additional data to evaluate the reasonableness of the quantities requested, or to ration the quantities to deliver if supplies are limited. Warehouse personnel at both the issuing and receiving facilities complete transaction records.

Transaction records are initiated any time a facility requests or issues supplies. They are completed when the receiving facility confirms receipt of the items shipped.

Transaction records are organized by date, which helps identify the transaction. It can then serve as a tickler—a reminder that a request was made and not yet received; or that an item was issued, but confirmation of receipt is still pending.

The standardized forms to be used by FDI/EPI stores are—

Form A-I: Stock Issue & Receipt Voucher for Routine Immunization

Form A-II: Stock Issue & Receipt Voucher for Supplementary Immunization Activities (SIAs)

Form B: Consumption & Requisition Form for Routine Immunization

Form C: Consumption & Requisition Form for SIAs

Copies of the forms with step-by-step guidelines on how to use/complete these forms are given below:



Expanded Program on Immunization, Government of Pakistan

Stock Issue & Receipt Voucher

(To be filled by Federal/Provincial/District Warehouses)

Routine Immunization



Supply from (Federal/Provincial): _____ Issued To (Province/District): _____ Date: _____

S.No	Products	Doses per vial	Manufacturer	Batch #	Expiry Date (MM/YY)	Unit Cost (\$)	Issue Quantity		Receive Quantity		VVM Stage	K
							Viials/ Nos. (F)	Total Doses (G = A x F)	Viials/ Nos. (I)	Total Doses (J = A x I)		
1	BCG	20	B	C	D	E						
2	DIL BCG											
3	TOPV	20										
4	Pentavalent	01										
5	Pneumococcal (PCV10)	02										
6	Measles	10										
7	DIL Measles											
8	TT	10										
9	TT	20										
10	HBV (Birth dose)	10										
11	IPV	10										
12	AD Syringes 0.5 ml											
13	AD Syringes 0.05 ml											
14	Recon. Syringes (2 ml)											
15	Recon. Syringes (5 ml)											
16	Safety Boxes											
17												
18												
19												
20												

Note: Use blank rows, if needed to add more than one batch received for one product/new products

Issued by – _____
 Name & Designation: _____
 Warehouse Name: _____
 Signature & Date: _____

Received by – _____
 Name & Designation: _____
 Warehouse/Store Name: _____
 Signature & Date: _____

How to use Form A-I

Stock Issue & Receipt Voucher for Routine Immunization

Note: This form replaces the old forms.

A – Stock receipt voucher from suppliers

B - Stock receipt voucher from warehouse

C – Stock issuance voucher

From/User Federal/ Provincial/ District EPI Stores

To/For Provincial/ Divisional/ District EPI Stores

Timeline As and when required

Step-by-step procedure

- The federal/provincial/district EPI store-in-charge will complete this form for issue/dispatch of vaccine to next level.

The form has three carbon copies—one each of white, yellow, and blue.

- Write issuing store name in the space “Supply from.”
 - Write receiving store name in the space “Issued to.”
 - Write the date of issue/dispatch.
 - The issuing store (federal/provincial) fills in columns B to H.
 - Write the manufacturer’s name in column B.
 - Write the batch/lot number in column C.
 - Enter the expiry date for each batch in column D as (MM/YY).
 - Write the unit cost in U.S. dollars in column E.
 - Enter the quantity issued as number of vials/syringes/safety boxes in column F.
 - Enter the quantity issued as number of vaccine doses in column G. To calculate, multiply number of doses per vial in column A with number of vials issued in column F.
 - Write VVM stage 1 or 2 in column H.
 - Write the name and designation of the person issuing the stock.
 - Write the name of the issuing warehouse.
 - Sign the form.
 - Keep one copy for the record and send two copies with the stock to the receiving store.
- The receiving store-in-charge (provincial/district) fills in columns I to K.
 - Enter the quantity received as number of vials/syringes/safety boxes in column I.

- 
- b. Enter the quantity received as number of vaccine doses in column J. To calculate, multiply the number of doses per vial given in column A; write the number of vials received in column I.
 - c. Write VVM stage 1 or 2 in column K.
 - d. Write the name and designation of the person receiving the stock.
 - e. Write the name of the receiving warehouse.
 - f. Sign the form.
 - g. Keep one copy for the record and send one copy back to the issuing store.



Expanded Program on Immunization, Government of Pakistan

Stock Issue & Receipt Voucher
(To be filled by District/Tehsil/Taluka Stores)



Campaigns (NID/SIA/Mop-up)

Supply from (District/Tehsil/Taluka): _____ Issued To (Tehsil/Taluka/UC): _____ Date: _____

S.No	Products	Doses per vial	Manufacturer	Batch #	Expiry Date (MM/YY)	Issue Quantity		Receive Quantity		VVM Stage
						Vials/Nos. (E)	Total Doses (F = A x E)	Vials/Nos. (H)	Total Doses (I = A x H)	
1	mOPV1	20	B	C	D					J
2	bOPV	20								
3	rOPV	20								
4	Measles	01								
5	DIL Measles									
6	TT	10								
7	AD Syringes 0.5 ml									
8	Recon. Syringes (5 ml)									
9	Safety Boxes									
17										
18										
19										
20										

Note: Use blank rows, if needed to add more than one batch received for one product/new products

Issued by – Name & Designation: _____
Store Name: _____
Signature & Date: _____

Received by – Name & Designation: _____
Store Name: _____
Signature & Date: _____

How to use Form A-II

Stock Issue & Receipt Voucher for SIAs

Note: This form replaces the old forms.

B - Stock receipt voucher from the warehouse

C – Stock issuance voucher

From/User District and Sub-district EPI Stores

To/For Tehsil/Union Council/Health Facility

Timeline As and when required

Step-by-step procedure

- The divisional/district EPI store-in-charge fills in this form for issue/dispatch of vaccine to next level.
 - The form has three carbon copies—one each of white, yellow, and blue.
 - a. Write the issuing store name in the “Supply from” space.
 - b. Write the receiving store name in the “Issued to” space.
 - c. Write the date of issue/dispatch.
 - d. The issuing store fills in columns B to G.
 - e. Enter the manufacturer’s name in column B.
 - f. Enter the batch/lot number in column C.
 - g. Use the blank rows if there is more than one batch of same vaccine.
 - h. Enter the expiry date for each batch in column D as (MM/YY).
 - i. Enter the quantity issued as number of vials/syringes/safety boxes in column E.
 - j. Enter the quantity issued as number of vaccine doses in column F. To calculate, multiply number of doses per vial in column A with number of vials issued in column E.
 - k. Write VVM stage 1 or 2 in column G.
 - l. Enter the name and designation of person issuing the stock.
 - m. Write the name of the issuing warehouse.
 - n. Sign the form.
 - o. Keep one copy for the record and send two copies with the stock to the receiving store.
5. The receiving store-in-charge (tehsil/Union Council (UC)/health facility) fills in columns H to J.
- a. Enter the quantity received as number of vials/syringes/safety boxes in column H
 - b. Enter the quantity received as number of vaccine doses in column I. To calculate, multiply number of doses per vial in column A with number of vials received in column H.
 - c. Write VVM stage 1 or 2 in column J.

- 
- d. Enter the name and designation of person receiving the stock.
 - e. Write the name of the receiving warehouse.
 - f. Sign the form.
 - g. Keep one copy for the record and send one copy back to the issuing store.

Form B (Sindh)



ROUTINE IMMUNIZATION MONTHLY VACCINATION REPORTING FORM SINDH



Month	Year
District	
Taluka	
Union Council	
Health Facility	

MONTHLY TARGETS	
Children Live Birth	
Surviving Children (0-11 M)	
Children Aged (12-23 M)	
2 Year and Above	
Pregnant Women	
Women Child bearing age (CBA)	

Filled By: _____ Date _____ Signature _____

EPI Center	Fixed Vaccinations Sessions		Outreach Vaccination Session	
	Planned	Actually Held	Planned	Actually Held
Functioning				
Non Functioning				
Reporting				

Product	Opening Balance (Doses)	Received (Doses)	Number of Children Vaccinated (0-11 Months)								Number of Children Vaccinated (12-23 Months)								2 Years and Above								Closing Balance (Doses)	Unusable (Doses) *
			Fixed				Outreach				Fixed				Outreach				Fixed				Outreach					
			Inside UC		Outside UC		Inside UC		Outside UC		Inside UC		Outside UC		Inside UC		Outside UC		Inside UC		Outside UC		Inside UC		Outside UC			
			M	F	M	F	M	F	M	F	M	F	M	F	M	F	M	F	M	F	M	F	M	F	M	F		
BCG																												
Hep B Birth Dose																												
OPV																												
	0																											
	1																											
	2																											
Pentavalent																												
	1																											
	2																											
Pneumococcal																												
	1																											
	2																											
IPV																												
Measles																												
	1																											

TT- Coverage

Product	Opening Balance (Doses)	Received (Doses)	S. No	Pregnant Women	CBAs	Closing Balance (Doses)	Unusable (Doses) *
TT			1				
			2				
			3				
			4				
			5				
			Total				

Other Items

Product	Opening Balance (No)	Received (No)	Dispensed (No)	Closing Balance (No)
Diluent BCG				
Diluent Measles				
AD Syringes 0.5 ml				
AD Syringes 0.05 ml				

Product	Opening Balance (No)	Received (No)	Dispensed (No)	Closing Balance (No)
Reconstitution Syringes (BCG-2 ml)				
Reconstitution Syringes (Measles 5 ml)				
Safety Boxes				

* Vaccine expired, exposed to heat or unusable due to any other reason to UC where children live

How to use Form B (Sindh)

Routine Immunization Monthly Vaccination Reporting Form (Sindh)

Note: This form replaces the old forms.

D – Monthly consumption reporting form (EPI center)

From/UserHealth Facility/Union Council/Tehsil

To/ForDistrict/Divisional/Provincial EPI centers

TimelineMonthly

Step-by-step procedure

- Only the health facility/UC EPI center fills in this form as a monthly consumption report.
- The form has three carbon copies—one each of white, yellow, and blue.
- EPI center sends the report to the respective tehsil.
- Tehsil EPI center compiles the reports from all its EPI centers into one Form B; the center sends the consumption report by 10th of every month to the respective district EPI center.
- Provincial EPI centers compile all the reports of respective districts/divisions into one form and send the monthly consumption report to FDI cell.

Routine Immunization

- a. Write health facility/store name, UC, Tehsil/Taluka, and district names.
- b. Write the month and year of the consumption report.
- c. Write the monthly targets for Children Live Birth, Surviving Children (0-11 M), Children Aged (12-23 M), 2 years and above, Pregnant Women and Women Child bearing age (CBA).
- d. Write the name of the person completing the form; sign the form and enter the date.
- e. Enter the number of doses available at the center on the 1st of the month in the Opening Balance column.
- f. Enter the number of doses received during the month in the Received column.
- g. Enter the number of doses administered to **FIXED** male and female children (inside and outside UC) from 0 to 11 months during the month.
- h. Enter the number of doses administered to **OUTREACH** male and female children from 0 to 11 months during the month.
- i. Enter the number of doses administered to **FIXED** male and female children (inside and outside UC) from 12 to 23 months during the month.
- j. Enter the number of doses administered to **OUTREACH** male and female children from 12 to 23 months during the month.

- k. Enter the number of doses administered to **FIXED** male and female children (inside and outside UC) for children 2 years and above during the month.
- l. Enter the number of doses administered to **OUTREACH** male and female children 2 years and above during the month.
- m. Enter the actual balance of vaccine in doses at the end of reporting month in the Closing Balance column.
- n. Enter the number of unusable doses (expired, damaged for any reason) during the month in the Unusable Doses column.

Td-Coverage

- a. Enter the number of doses available at the center on 1st of the month in the Opening Balance column.
- b. Enter the number of doses received during the month in the Received column.
- c. Enter the number of doses administered to PREGNANT WOMEN during the month.
- d. Enter the number of doses administered to CBAs (15-49 years) during the month.
- e. Enter the actual balance of vaccine in doses at the end of reporting month in the Closing Balance column.
- f. Enter the number of unusable doses (expired, damaged for any reason) during the month in the Unusable Doses column.

Other Items

- a. Enter the number of items available at the center on the 1st of the month in the Opening Balance column.
- b. Enter the number of items received during the month in the Received column.
- c. Enter the number of items dispensed during the month.
- d. Enter the actual number of items at the end of reporting month in the Closing Balance column.
- e. Keep one copy for the record and send two copies to the respective tehsil/district.

Form B (Punjab)



ROUTINE IMMUNIZATION MONTHLY VACCINATION REPORTING FORM PUNJAB



Month _____	Year _____	Outreach Vaccination Session		Monthly Targets	
District _____		Planned	Actually Held	Total Population of UC	
Tehsil _____				Pregnant Women	
Union Council _____				Live Birth (For BCG)	
Health Facility _____				Surviving Children (0-11 M)	
				Children (12-23 M)	

Antigen	Opening Balance (Doses)	Received (Doses)	Number of Children Vaccinated (0-11 Months)								Number of Children Vaccinated (12-23 Months)								2 Years and Above								Unusable (Doses) **	Closing Balance (Doses)
			Fixed				Outreach				Fixed				Outreach				Fixed				Outreach					
			Inside UC		Outside UC*		Inside UC		Outside UC		Inside UC		Outside UC		Inside UC		Outside UC		Inside UC		Outside UC		Inside UC		Outside UC			
Dose No	M	F	M	F	M	F	M	F	M	F	M	F	M	F	M	F	M	F	M	F	M	F	M	F				
BCG																												
Hep-B Birth Dose																												
OPV			0																									
			1																									
			2																									
			3																									
Pentavalent			1																									
			2																									
			3																									
Pneumococcal			1																									
			2																									
			3																									
IPV			1																									
			2																									
Measles			1																									
			2																									
Rota			1																									
			2																									
			3																									
dT			1																									

TT-Coverage

Antigen	Opening Balance (Doses)	Received (Doses)	Dose No	Pregnant Women		CBA (15-45 Years age)		Unusable (Doses) **	Closing Balance (Doses)
				Inside UC	Outside UC	Inside UC	Outside UC		
TT			1						
			2						
			3						
			4						
			5						

Other Items

Product	Opening Balance (No)	Received (No)	Dispensed (No)	Closing Balance (No)
Diluent BCG				
Diluent Measles				
AD Syringes 0.5 ml				
AD Syringes 0.05 ml				

Product	Opening Balance (No)	Received (No)	Dispensed (No)	Closing Balance (No)
Reconstitution Syringes (BCG-2 ml)				
Reconstitution Syringes (Measles 5 ml)				
Safety Boxes				

Filled By _____ Date _____ Signature _____ Checked By _____ Date _____ Signature _____
(Name and Designation) (Name of MO/Facility Incharge)

* Children vaccinated from other UCs must be filled with red ink in daily register

** Vaccine expired, exposed to heat (VVM Stage 3 & 4), Label removed or broken

Form B (Balochistan)



ROUTINE IMMUNIZATION MONTHLY VACCINATION REPORTING FORM BALOCHISTAN



Month _____	Year _____	Outreach Vaccination Session		Monthly Targets
District		Planned	Actually Held	Total Population of UC
Tehsil				Pregnant Women
Union Council				Live Birth (For BCG)
Health Facility				Surviving Children (0-11 M)
				Children (12-23 M)

Antigen	Opening Balance (Doses)	Received (Doses)	Number of Children Vaccinated (0-11 Months)								Number of Children Vaccinated (12-23 Months)								2 Years and Above								Unusable (Doses) **	Closing Balance (Doses)
			Fixed		Outside UC *		Outreach		Fixed		Outside UC		Outreach		Fixed		Outside UC		Outreach									
			Inside UC	Outside UC	Inside UC	Outside UC	Inside UC	Outside UC	Inside UC	Outside UC	Inside UC	Outside UC	Inside UC	Outside UC	Inside UC	Outside UC	Inside UC	Outside UC	Inside UC	Outside UC								
			M	F	M	F	M	F	M	F	M	F	M	F	M	F	M	F	M	F	M	F	M	F				
BCG			1																									
Hep-B Birth Dose			1																									
			0																									
OPV			1																									
			2																									
			3																									
Pentavalent			1																									
			2																									
			3																									
Pneumococcal			1																									
			2																									
			3																									
IPV			1																									
Measles			1																									
			2																									
Rota			1																									
			2																									
			3																									
dT			1																									

TT- Coverage

Antigen	Opening Balance (Doses)	Received (Doses)	Dose No	Pregnant Women		CBA (15-45 Years age)		Unusable (Doses) **	Closing Balance (Doses)
				Inside UC	Outside UC	Inside UC	Outside UC		
TT			1						
			2						
			3						
			4						
			5						

Other Items

Product	Opening Balance (No)	Received (No)	Dispensed (No)	Closing Balance (No)	Product	Opening Balance (No)	Received (No)	Dispensed (No)	Closing Balance (No)
Diluent BCG					Reconstitution Syringes (BCG-2 ml)				
Diluent Measles					Reconstitution Syringes (Measles 5 ml)				
AD Syringes 0.5 ml					Safety Boxes				
AD Syringes 0.05 ml									

Filled By _____ Date _____ Signature _____ Checked By _____ Date _____ Signature _____
(Name and Designation) (Name of MO/Facility Incharge)

* Children vaccinated from other UCs must be filled with red ink in daily register

** Vaccine expired, exposed to heat (VVM Stage 3 & 4), Label removed or broken

How to use Form B (GB, FATA, AJK & ICT)

Consumption & Requisition Form for Routine Immunization

Note: This form replaces the old forms.

D – Monthly consumption reporting form (EPI center)

E – Provincial Vaccine Requisition Form

F – Divisional/District/Sub-District Vaccine Requisition Form

G – Union Council (EPI Center) Vaccine Requisition For

From/ UserHealth Facility/Union Council/Tehsil

To/For District/Divisional/Provincial EPI centers

Timeline Monthly

Step-by-step procedure

- The health facility/UC, district/division, and provincial EPI centres fills in this form as a monthly consumption report and requisition for the next month.
- The form has three carbon copies—one each of white, yellow, and blue.
- EPI center sends the report & requisition to the respective district.
- District EPI center compiles the reports from all its EPI centers into one form B and sends the consumption & requisition report by 10th of every month to the respective provincial EPI center.
- Provincial EPI centers compile all the reports from the respective districts/divisions into one form and sends the monthly consumption & requisition report to FDI cell.
 - a. Write the health facility/store name, UC, tehsil/taluka, district, and province names.
 - b. Write the month and year of the consumption report
 - c. If it is a district report, write the district and province name.
 - d. The reporting center fills in columns B to I.
 - e. the respective stock issuing EPI store fills in column J.
 - f. Enter the number of doses available at the center on the 1st of the month in column B.
 - g. Enter the number of doses received during the month in column C.
 - h. Enter the number of doses administered during the month in column D.
 - i. Enter the number of vials used during the month in column E.
 - j. Enter the number of unusable vials (expired, damaged for any reason) during the month in column F.
 - k. Enter the actual balance of vaccine vials at the end of reporting month in column G.

- 
- l. Enter the maximum stock level (number of vials) for the respective facility, which should equal two months requirement for districts/health facility and six months for the province.
 - m. Enter the number of vaccine vials required for the next month, which should equal the number of vials in column H minus the number of vials in column G.
 - n. Write the name and designation of the person completing the form; sign the form and enter the date.
 - o. Keep one copy for the record and send two copies to the respective district/province.
 - p. The respective province/district fills in column J; enter the number of vials issued to the respective district/EPI center.



Expanded Program on Immunization, Government of Pakistan

Demand, Consumption & Receipt Form



Campaigns Type ()

UC _____ Tehsili: _____ District: _____ Province: _____ Campaign Date: from _____ to _____ (MM/YY)

Product	DEMAND				CONSUMPTION							
	Doses per Vial	Target #	Wastage factor	Required		Opening Balance	Requested G = E - F	Received	Children Vaccinated/ Doses Administered	Vials Used	Unusable Vials	Closing Balance
				Doses D = B x C	Vials/Nos. E=D/A							
mOPV1	20	B	C	D	E	F	G	H	I	J	K	L
bOPV	20		1.12									
tOPV	20		1.12									
Measles	10		1.11									
DIL Measles												
TT	20		1.11									
AD Syringes 0.5 ml												
Recon. Syringes (5 ml)												
Safety Boxes												

Note:

- i. Use blank rows, if needed to add more than one batch received for one product/new products
- ii. Columns B to G to be filled and sent to the issuing authority at least 2 weeks before the SIA. Column H to K to be filled and sent within 1 week after completion of the SIA

Requested by –
 Name & Designation: _____
 Store Name: _____
 Signature & Date: _____

Received by –
 Name & Designation: _____
 Store Name: _____
 Signature & Date: _____

Reported by –
 Name & Designation: _____
 Store Name: _____
 Signature & Date: _____

How to use Form C

Consumption & Requisition Form for SIAs

Note: This form replaces the old forms.

D – Monthly consumption reporting form (EPI center)

E – Provincial Vaccine Requisition Form

F – Divisional/District/Sub-District Vaccine Requisition Form

G – Union Council (EPI Center) Vaccine Requisition Form

From/ UserHealth Facility/Union Council/Tehsil

To/For District/Divisional/Provincial EPI centers

Timeline Requisition 2 weeks before SIA. Report within one week of SIA

Step-by-step procedure

- The health facility/UC, district/division, and provincial EPI center fills in this form as a consumption report for every SIA.
- The form has three carbon copies—one each of white, yellow, and blue.
- EPI center fills in the columns B to G at least two weeks before the SIA, then sends the requisition to the respective district/province.
- EPI center, to complete the form, fills in columns H to L, then sends it to the respective district/province within one week after the SIA is complete.
- District EPI compiles the reports from all its EPI centers into one Form C and send the report to the respective provincial EPI center.
- Provincial EPI centers compile all the reports from the respective districts/divisions into one form and sends the report to FDI cell.
 - a. Write the health facility/store name, UC, tehsil/taluka, district, and province names.
 - b. Write the date, month, and year of the SIA.
 - c. For the district report, write only the district and province name.
 - d. Enter the targeted number of children to be vaccinated during the SIA in column B.
 - e. Enter the number of doses required for the target in column D, including the wastage; multiply the number in column B and the wastage factor in column C.
 - f. Enter the number of vials required in column E; divide the number of doses in column D with column A.
 - g. Enter the number of vials available at the center as the balance from the previous activity in column F.
 - h. Enter the number of vials to be requisitioned in column G by subtracting F from E.
 - i. Enter the number of vials received for the activity from respective district/province in column H.

- 
- j. After the activity, fill in the columns I to L.
 - k. Enter the number of doses administered during the activity in column I.
 - l. Enter the number of vials used during the activity in column J.
 - m. Enter the number of unusable vials (expired, damaged for any reason) during the activity in column K.
 - n. Enter the actual balance of vaccine vials at the end of activity in column L.
 - o. Write the name and designation of the person completing the form; sign the form and enter the date.
 - p. Keep one copy for the record and send two copies to the respective district/province.
 - q. The respective province/district compiles the report and sends it to the respective provincial/federal EPI center.

Campaign Data Entry Form

Data Entry (Control Room)

Campaign
 Measles SIAs **UC** **Day** **Daily Target**

Household Visited **Product** **Household with Multiple Families**

Age 0-5 Months **Age 6-59 Months** **Total Coverage**

Refusal Covered **Covered Mobile Children** **Covered NA/Missed** **Rec NA/Missed**

Rec. Refusal **Reported with Weakness** **Zero Dose < Year** **No. of Teams Reported** **Inaccessible Coverage**

Vials Given **Vials Used** **Vials with stage 3 or 4** **Vials Returned**

Save

4.3 Structure of the Web-based LMIS, its Process, and Use

The Pakistan web-based LMIS is transparent for all stakeholders, based on user rights; it is easy to use and it integrates both routine and special immunization campaign vaccine logistics data. Standardized reporting forms and data triangulation are used to validate data and improve visibility for wastage rates.

Resupply quantities for routine FDI/EPI are calculated based on average monthly consumption and stock balances; wastage rates are calculated automatically. The stock balance, consumption, and issued data, and losses and adjustments, are also collected.

To collect data from service delivery points, new routine reporting forms are automatically printed using vLMIS inventory management module, with vaccine logistics SOPs for each level of the supply chain.

4.3.1 Features

Vaccine Logistics Management Information System provides the following features:

Role-Based Access for Users

Users are authenticated based on their geographical levels and the roles associated with them.

Inventory Management

Stock issued, received, and adjusted are recorded, by transaction, in the vLMIS by the FDI/EPI store users.

Automated Stock Transactions

Stock transactions are updated in the system and calculated automatically for transfers and adjustments using vLMIS for managing inventory better.

Cold Chain Assets

The details of cold chain assets, their location, status, and capacity is tracked in the vLMIS to maintain the cold chain for immunization vaccines.

Batch Management & Bar Coding

vLMIS offers batch management in order to maintain the FEFO for vaccine during stock issue.

Consumption Reporting

Service delivery point data will be collected and recorded daily and compiled and reported online monthly using the vLMIS.

Data Reports

Performance reports enable the user to view the monthly reporting performance countrywide.

Graph and Maps

Graphs and maps enable the user to view and compare different Indicators and view performance and comparison reports over time.

Authenticated EPI Users

Responsibilities	National	Feature	Provincial	District	Tehsil	UC
Receive stock from other provincial warehouses.	✓	Inventory Management	✓	✓	✓	✓
Receive stock from supplier and create placement vouchers.	✓		✓	✓	✓	✓
Search for received stock.	✓		✓	✓	✓	✓
Issue stock to other warehouses (province, district, and field stores) and create pick order forms.	✓		✓	✓	✓	✓
Search for issued stock.	✓		✓	✓	✓	✓
Manage batches.	✓		✓	✓	✓	✓
Add placement locations for stock.	✓		✓	✓	✓	✓
Transfer stock to other locations.	✓		✓	✓	✓	✓
Manage adjustments.	✓	Stock Adjustments	✓	✓	✓	✓
Search for adjustments	✓		✓	✓	✓	✓
Issue a new gate pass.	✓	Manage Gate Pass	✓	✓	✓	✓
View the list of issued gate passes.	✓		✓	✓	✓	✓
Manage cold chain assets.	✓	CCEM	✓	✓	✓	✓
Asset working status update.	✓		✓	✓	✓	✓
View geographical and periodic logistics information in tabular formats.	✓	Reports	✓	✓	✓	✓
View geographical and periodic CCEM information in tabular formats.	✓	CCEM Reports	✓	✓	✓	✓
View geographical and periodic inventory management information in graphical formats.	✓	IM Graphs	✓	✓	✓	✓
View geographical and periodic cold chain equipment management information in graphical formats.	✓	CCEM Graphs	✓	✓	✓	✓
View geographical and periodic logistics information in map formats.	✓	Maps	✓	✓	✓	✓
View geographical and periodic campaign information in tabular formats.	✓	Campaign Reports	✓	✓	✓	✓
Change account password.	✓	Others	✓	✓	✓	✓

Policy User

Feature	Responsibilities	National	Provincial	District
Reports	View geographical and periodic logistics information in tabular formats.	✓	✓	✓
CCEM Reports	View geographical and periodic CCEM information in tabular formats.	✓	✓	✓
CCEM Graphs	View geographical and periodic cold chain equipment management information in graphical formats.	✓	✓	✓
IM Graphs	View geographical and periodic inventory management information in graphical formats.	✓	✓	✓
Campaign Reports	View geographical and periodic campaign information in tabular formats.	✓	✓	✓
Others	Change account password.	✓	✓	✓

Campaign User

Feature	Responsibilities	National	Provincial	District
Campaigns	Add campaign.	✓	✓	
	Search campaigns.	✓	✓	✓
	Data entry history.	✓	✓	✓
	Campaigns target.	✓	✓	✓
	LQAS data entry.	✓	✓	✓
Campaign Reports	View geographical and periodic campaign information in tabular formats.	✓	✓	✓
Others	Change account password.	✓	✓	✓

CCEM Manager

Feature	Responsibilities	National	Provincial	District
CCEM	Search refrigerator.	✓	✓	✓
	Add refrigerator.	✓	✓	✓
	Search vaccine carriers.	✓	✓	✓
	Add vaccine carriers.	✓	✓	✓
	Search ice pack.	✓	✓	✓
	Add ice pack.	✓	✓	✓
	Search cold room.	✓	✓	✓
	Add cold room.	✓	✓	✓
	Search voltage regulator.	✓	✓	✓
	Add voltage regulator.	✓	✓	✓
	Search generator.	✓	✓	✓
	Add generator.	✓	✓	✓
	Search transport.	✓	✓	✓
	Add transport.	✓	✓	✓
	Transfer asset.	✓	✓	✓
	Asset status update.	✓	✓	✓
CCEM Reports	View geographical and periodic CCEM information in tabular formats.	✓	✓	✓
CCEM Graphs	View geographical and periodic cold chain equipment management information in graphical formats.	✓	✓	✓
Others	Change account password.	✓	✓	✓

Geographical Areas

The geographical distribution of areas is displayed below. Data are reported on 4th and 5th levels, while stock transactions are recorded on layer 1–3. Data in all layers are segregated in vLMIS. It is possible to enter aggregated data in layer 4 (tehsil) and layer 5 (UC) because they do not have Internet infrastructure in the sub-districts and other remote areas.

Layer	Geographical Area
Layer 1	National
Layer 2	Provincial/Regional
Layer 3	District
Layer 4	Tehsil
Layer 5	UC

4.3.2 Homepage

After the user enters the URL <http://vlmis.gov.pk>, a user interface (homepage) is displayed. The homepage displays a basic introduction to the Pakistan LMIS.

The screenshot shows the homepage of the Vaccines LMIS. At the top left, there are logos for EPI (Information Management Systems) and Vaccine (vLMIS) (Pakistan Logistics Management Information System). A navigation bar contains links for 'Vaccine', 'Contact Us', and 'FAQs'. The main banner area features the text 'MANAGEMENT INFORMATION SYSTEM' and 'VACCINES LOGISTICS' in large letters, with a sub-description: 'Manages the national immunization programmes by providing a well-designed logistics management information system for vaccines. Supports Data Collection ..'. Below the banner is a 'Vaccines LMIS USER LOGIN' section. It includes two input fields: 'USER NAME *' with the value 'user_cd' and 'PASSWORD *' with the value '*****'. A red arrow points to the user name field with the label 'Type user name', and another red arrow points to the password field with the label 'Type Password'. To the right of the password field are two buttons: 'Login' and 'Forgot Password?'.

4.3.3 User Login:

Two types of users can log in into the LMIS:

- Guests
- Stakeholder specific users

4.3.3.1 Guests

Guests can log in to the LMIS by entering username and password as guest. When guests log in, they use the menu where they can view analytical reports, graphs, and warehouse/district stores data entered by stakeholder specific users for any period. However, they cannot edit the data.

The sidebar displays the menu area for accessing different features:

Dashboard:

Dashboard is a visual display of the most important information needed for one or more objectives; the information is consolidated and arranged on a single screen so it can be seen at a glance.

Clicking “Dashboard” on the sidebar displays four streams of data dashboards and three levels (i.e., national-, provincial-, and district-level).

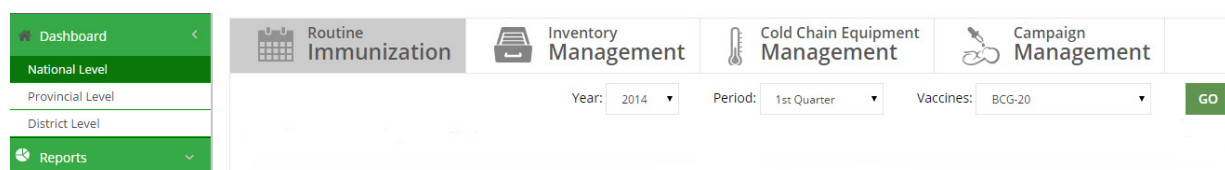
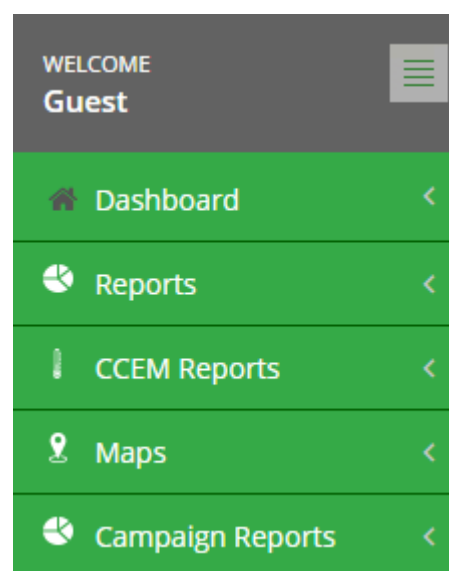

Pakistan's Daily Immunization Performance:

This page presents overall analytics of data in the form of following dashboards:

- Cold chain capacity
- Stock status
- Stock priority

Users can further drill down the dashboards to view the product wise usable summary and priority vaccines distribution detail.

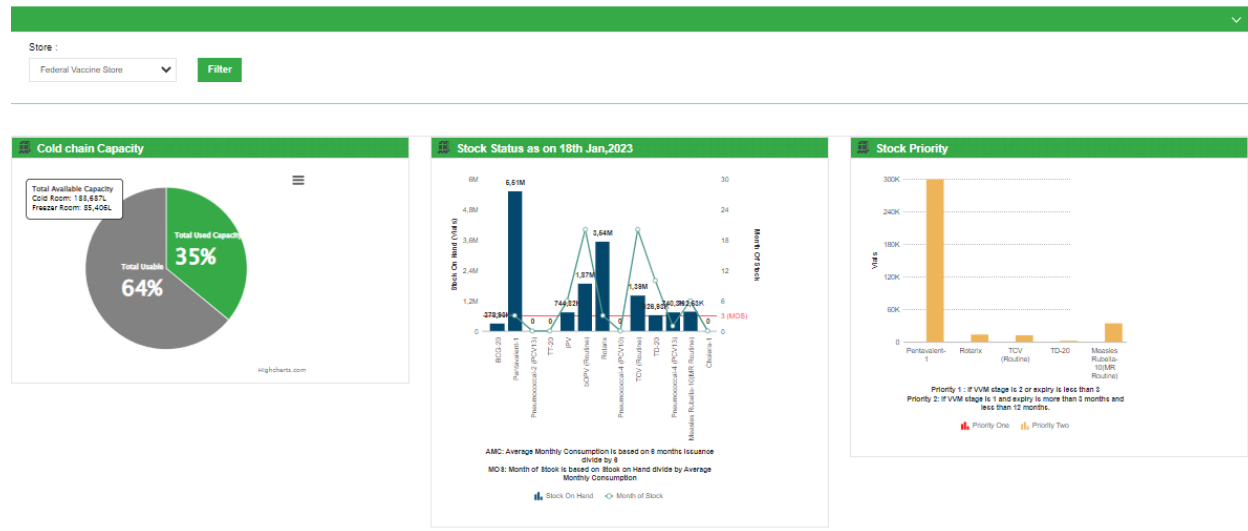

Reports:

Clicking “Reports” on the sidebar displays the list of reports for the three levels (i.e., national-, provincial-, and district-level).

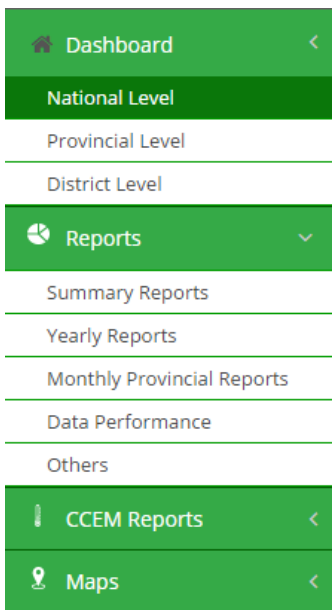

Report Table

- **Products:** displays the list of vaccines.
- **Consumption:** displays the consumption data of vaccines for the last reported month. The data for each vaccine is the sum of all reporting levels.
- **Average monthly consumption** is calculated as average of aggregated consumption for the last three non-zero consumption months.
- **Stock on hand:** the amount of product on hand in order to monitor stock positions and anticipate stockouts in advance.
- **Month of stock** is the estimate of number of months the stock will last. This calculation is based on average monthly consumption.

$$\frac{\text{Stock on Hand}}{\text{Average Monthly Consumption}}$$

Similarly, clicking “CCEM Reports” and “Maps” on the sidebar displays the Cold Chain Equipment reports and geographical maps, respectively, for the three levels (i.e., national-, provincial-, and district-level).

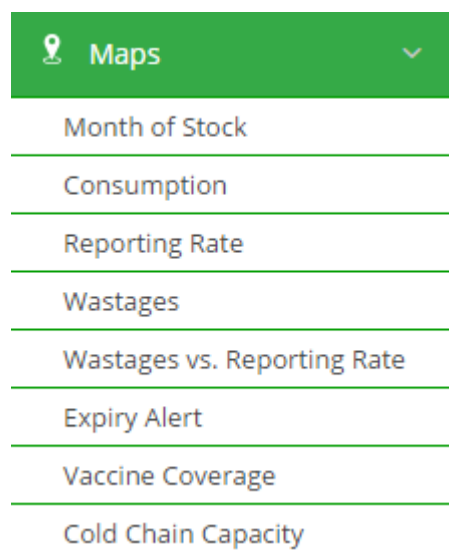
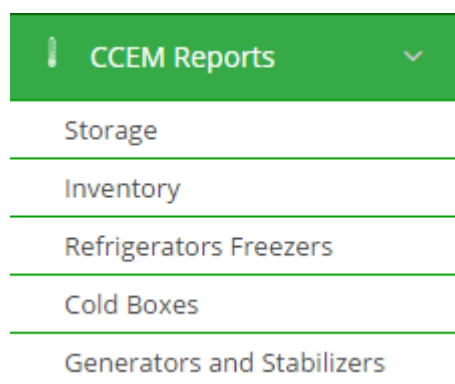

4.3.3.2 Specific Users

The vLMIS enables an authenticated user to log in to view different dashboards. These dashboards are available to different level users such as—

- National level dashboards
- Provincial level dashboards
- District level dashboards

Logging in to the FDI Centre Operator account displays the account’s homepage screen, by default. The federal and provincial center user maintains and manages the warehouse’s monthly inventory, by recording the stock consumption on a daily basis. The data is then compiled and updated monthly on the vLMIS. This data includes the inventory consumption—stock status and consumption details—with the cold chain assets status of the warehouse/store. The FDI/EPI user can also view the Reports and Graphs features of the vLMIS.

4.3.3.3 Stakeholder specific login (personalization)

To obtain LMIS data and reports, the user must successfully log in with their username and password. System users are defined by relevant stakeholders and the level in the supply chain they represent. The user will be given a username and password. Once successfully logged on, the user will be directed to a user information page, specific to the level, and based on the privileges assigned to the user by the system administrator. This page will contain specific information about the user’s facility/store.

The following table includes the activities that various users will be able to perform after they log in:

Level	Data Entry	Reports	Graphs
FDI/EPI center user	✓	✓	✓
UC level	✓	✓	✓
Tehsil	✓	✓	✓
District	✓	✓	✓
Province		✓	✓
National		✓	✓

4.3.3.4 EPI store user

The EPI store user is at the top tier of the vaccine supply chain, and they maintain/manage the supply and demand of vaccines countrywide. The EPIstore user can receive stock by suppliers and issue them to the provincial, divisional, and district warehouses, and can maintain the inventory records in vLMIS—stock received, issues and stock adjustments. Additionally, they can also add assets to cold chain inventory and transfer them to other warehouses. The EPI store user can also view the Reports and Graphs features of the vLMIS.

The EPI store user maintains the EPI warehouse records in the vLMIS, which includes the day-to-day stock transactions. The following users will have an FPI store user account in the vLMIS:

- National/Federal Warehouse vLMIS Operator
- Provincial Warehouse vLMIS Operator
- Divisional Warehouse vLMIS Operator
- District Store vLMIS Operator.

4.4 Computer Systems

The federal and provincial store staff will use the software and computer equipment most suitable for the task; responsible personnel must know how to use the system, in particular—

- a. The computer system running the software must be kept free of computer viruses.
- b. Data files must be backed up on a daily basis and the backup media must be kept in a safe place.
- c. Stock records must be accurate and up-to-date.
- d. Program managers must receive regular reports on the status of vaccines and other immunization supplies.

4.4.1 Associated materials and equipment

The store section must have a computer system, software, and peripherals with the following specifications to run the stock control program.

- a. The computer system must be fitted with a voltage regulator and an uninterruptible power supply (UPS) device.
- b. The computer system must have a broadband Internet connection that is password-protected and permanently connected during working hours.
- c. A high-quality anti-virus and malware package must be installed and the subscription(s) for updates must be fully funded and paid for as routine recurrent expenditure. The software must be configured to download updates whenever the computer is connected to the Internet, and to carry out daily automatic anti-virus and anti-spyware scanning.
- d. The system administrator must ensure that the system firewall is properly configured. All ports not commonly used to browse the Internet should be blocked; preferably only the ports that are essential for managing the stock management process should be enabled.
- e. Only the authenticated software packages that are directly related to the task of managing the vaccine store may be loaded onto the computer

4.4.2 Instructions for Data Entry Operators

- a. The computer must be password-protected.
- b. Always use an agreed-to date format (for example, mm/dd/yyyy).
- c. Only officially authorized backup devices may be attached to the computer. No unauthorized USB key (flash drive device), CD, DVD, or external hard disc should be used at any time. Only the Statistical Investigator Stores can authorize the use of these devices.
- d. Process all stock arrivals and dispatches using the vLMIS/warehouse management system (WMS). No transactions may be made outside the system and no supplies must leave the store without an Issue Voucher generated by the vLMIS/WMS.
- e. Ensure that full details of all transactions are completely entered immediately after they occur.
- f. Respond immediately to all anti-virus software update instructions.

For further details on vLMIS features and use, please refer to vLMIS user manual available at www.vlims.gov.pk



5. COVID Supply Chain Management

5.1 Key Components of COVID Supply Chain

An uninterrupted supply of vaccines is a pre-requisite and a challenge for national vaccination programs. The emergence of COVID-19 vaccines has generated immense excitement, but healthcare systems around the world now face the complex task of securing and distributing supplies to their populations and administering the vaccine. Acquiring sufficient quantities is just the start; the vaccines must then be transported safely to multiple destinations, maintained at the right temperature, and tracked at all times to avoid tampering and assure product integrity and delivery. Designing an effective and sustainable supply chain system for COVAX and other vaccines is important to ensure robust supply planning and forecasting, timely procurement, rationalize storage and distribution, efficient transport, reduce wastage, and provide real time information system as illustrated in the below diagram.

In Pakistan, the EPI is managing COVID vaccine supply chain at the federal, provincial, district, and EPI centers level. COVID vaccines are procured either through government sources or receive through donations and COVAX facility. FDI receive the vaccines at the Central Warehouse at Islamabad and then distribute under the standard guidelines to provincial warehouses as per need/ targets. The Provincial EPI programs are responsible to further distribute COVID vaccines to their concerned districts and onward to vaccination centers as per need/ targets. Figure-1 indicates COVID vaccine supply chain flow in Pakistan. For effective COVID supply chain management, following key areas need to be considered:

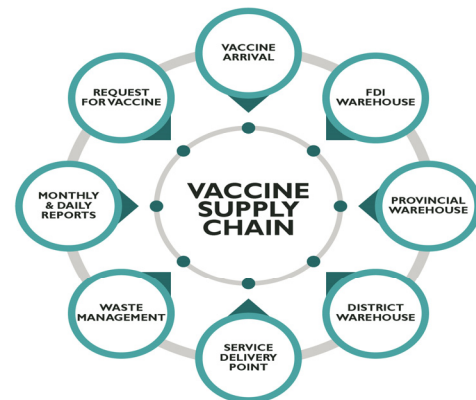

Figure 47. Key Components of COVID Supply Chain

5.1.1 Planning is the Key to Success

An effective supply chain puts the vaccine receiver at its heart, and aims for speedy execution with minimum wastage, at an agreed and understood cost-to-serve. It should make the most of existing distribution and cold storage capabilities and offer the potential to scale up if necessary. Good planning is necessary to understand the capacity of infrastructure and critical assets (e.g., cold chain) to be able to deliver in an effective way. When millions of doses of COVID vaccine are needed, demand and planning become more important. Those responsible for procurement should swiftly evaluate different manufacturers of vaccines, syringes and refrigeration equipment, determined in part by their location, capacity, and compliance with licensing and other regulatory requirements. With a number of vaccines available — and more possibly in the pipeline — there is the option to use multiple manufacturers. While this can increase volume, it also adds to complexity, as different products may require different storage conditions and have varying expiry dates.

5.1.2 Keep Vaccines at the Correct Temperature

Cold storage is an integral part of the COVID-19 vaccine supply chain. Ultra cold chain (UCC) refers to the storage and transportation of vaccines and other medical products at extremely low temperatures, typically ranging from -70°C to -80°C or even lower. The ultra cold chain is an important part of the global cold chain infrastructure, especially for COVID-19 vaccines that require ultra cold storage, such as the Pfizer-BioNTech and Moderna vaccines. The massive amount of vaccine that are being manufactured and distributed could show capacity issues in cold chain storage. In addition to ramping up the cold storage infrastructure, supply chain managers need end-to-end temperature logging, as well as real-time monitoring and reporting of temperature, shock and moisture — with system alerts via automated scanners, to maintain warehouse integrity. This allows time for remedial action to prevent damage and spoilage and prevents compromised goods in transit from reaching to end point.

5.1.3 Track and Trace

Complete, end-to-end inventory visibility is vital, to understand when vaccines will be available for use, and to avoid damage or theft. Data on tags from COVID-19 vaccine batches enable efficient tracking, giving supply chain managers a complete picture of the volumes stored or in transit, as well as any vaccines delivered but not yet used. Stock can also be identified according to the manufacturer and expiry date — which is important, given the relatively short shelf life. All of which enables better demand planning, to inform decisions on ordering, distribution, order allocation, storage and returns, optimizing product flows and avoiding overload and wastage.

Post-vaccination tracking is vital in evaluating efficacy but can only be effective if there are mechanisms to adverse events i.e., record successful/unsuccessful treatments and side-effects. It would also enable distribution and application centers to efficiently plan for second dosage and recurring applications for the vaccine to further eliminate the risk of incompatible vaccine brands.

Track and trace call for a robust data analytics capability, and an established process for capturing, storing, transferring and processing real-time data.

5.1.4 Ensure Product Integrity

Like many supply chains, vaccines can be vulnerable to counterfeiting, tampering, contamination and theft — especially as products and components often passing through multiple locations and countries.

Provenance and authenticity are critical, to assure end users of the vaccines' safety and efficacy. Batches should be serialized for easy identification, with proof of pick-up and delivery confirmed via an authenticated chain of custody, reported through information systems. These should detect any anomalies and send alerts — visible to all key supply chain managers — and be able to trace the source of any unauthorized intervention. Anyone coming into contact with the vaccines must be trained in identifying counterfeits. Comprehensive assessment and monitoring also places the purchaser of the vaccine in a stronger position, should they need to make any insurance claims for unusable stock.

5.1.5 Manage last-mile Delivery, Returns and Post-Vaccine Tracking

Last-mile delivery is one of the most critical parts of the COVID-19 vaccine supply chain. The number and location of vaccination sites will be determined by the percentage of population to be vaccinated,

the priority groups, the population density, availability of trained frontline workers, and the distance the target population must travel to access health facilities.

Longer-distance journeys of bulk vaccine freight are typically made by larger refrigerated trucks, with smaller trucks and carriers taking over for the ‘last-mile’, performing multiple drops to healthcare centers and vaccination points.

Accurate volume flow is critical to avoid wastage: even the larger distribution points can only accept 5–7 days of stock due to on-site capacity limitations and cold chain requirements.

The last-mile delivery vehicles must be equipped with cold chain storage and sufficient cargo facilities, taken by licensed drivers, and integrated into track and trace systems to assure 24/7 visibility for both delivery and returns (due to expired stock, overstocking, or damaged stock). Ideally, one truck or carrier should manage both outbound fulfilment and returns, offering transport, processing, storage and destruction. They will be responsible for the integrity of returns and show truck or carrier should manage both outbound fulfilment and returns, offering transport, processing, storage and destruction. They are also responsible for the smooth return of vaccines and make sure no vaccines have been replaced or stolen.

5.2 COVID Management Information System

COVID-19 pandemic has caused worldwide crisis including Pakistan. Strong enabling environments and advanced and digitized health information systems are vital to controlling epidemics. Managers of supply chains depend on timely and accurate data to make informed and effective decisions about routine operations like forecasting demand and resupplying health facilities. Data also inform strategic decisions to make supply chain design, processes and workforce more efficient and cost-effective.

With the technical support of USAID, the FDI has developed COVID-MIS. It is an integrated platform that has reverse logistics module, vaccination data from NIMS (National Immunization Management System) along with the meaningful articulation of data fetched through COVIM interfacing. This provides tools to analyze data and use the information to make decisions for effective COVID-19 vaccine management including funds allocation, source, origin, and number of people vaccinated etc. The system also provides tools to analyze reverse logistics data and stock management.

COVID MIS is playing vital role in reflecting data analytics of COVID vaccine at different level and help to manage COVID vaccine inventory at the Federal level warehouse. The user can view or analyze COVID vaccine data from different prospects which can be used in policy development for the country. It is easy to understand the COVID vaccine stock movement and stock availability.

The dashboard allows users to quickly view COVID stocks in graphical manners applying business intelligence for specified time frame through date filters:

- Antigen wise Vaccine Received
- Vaccine Received by Major Funding Source
- Regional Sourcing of Vaccine
- Vaccine Sourcing Types (Government Procurement, Donation, and COVAX Facility)
- Vaccine Received Yearly Comparison
- Vaccine Stock Status

- Vaccine Doses and its administration
- Reverse Logistic Activity Status

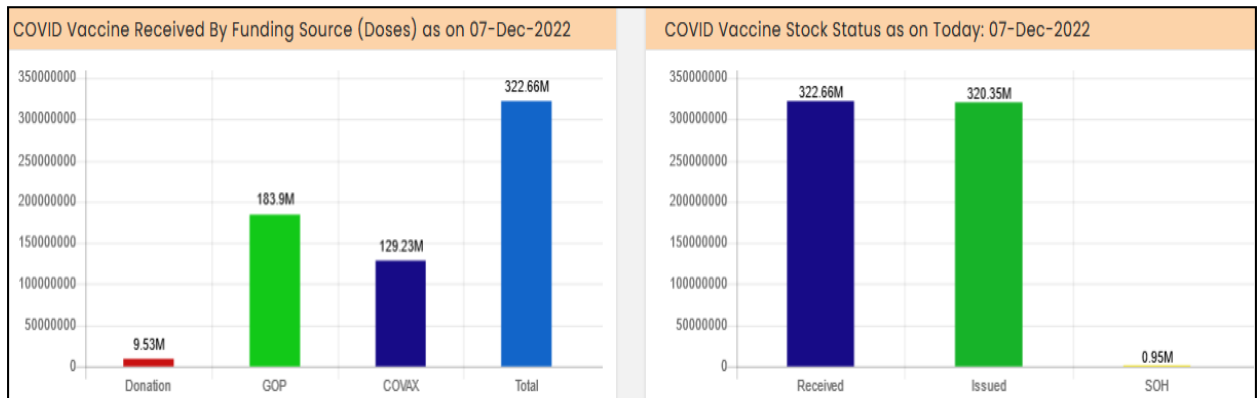
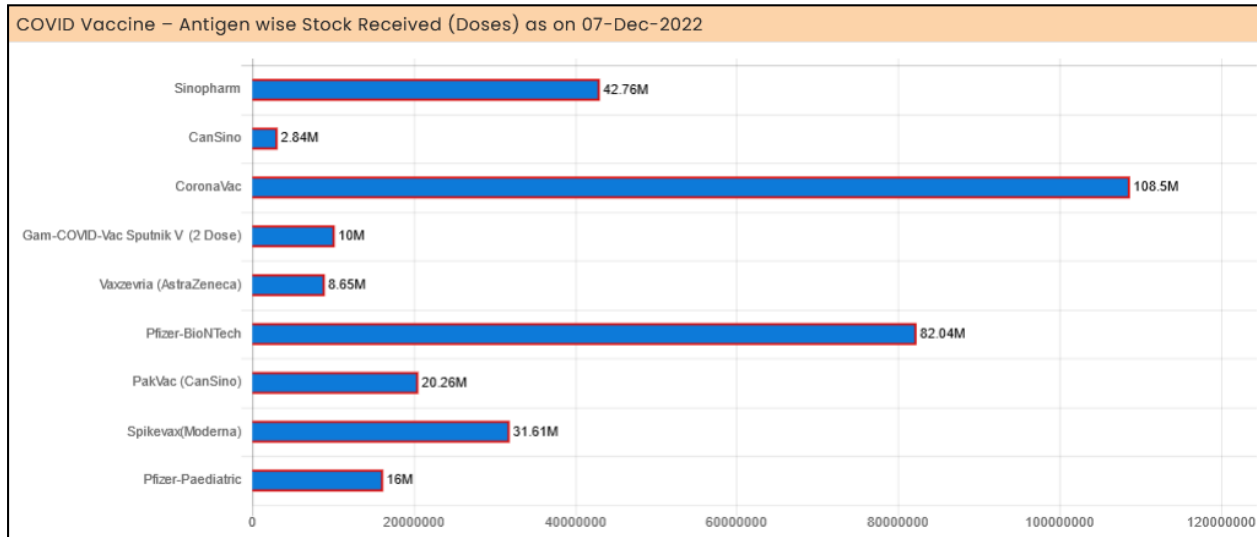

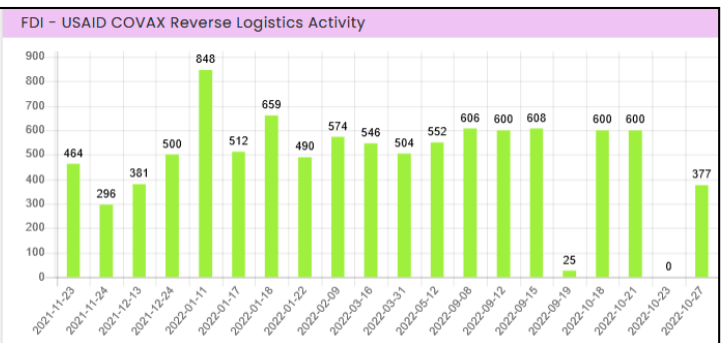
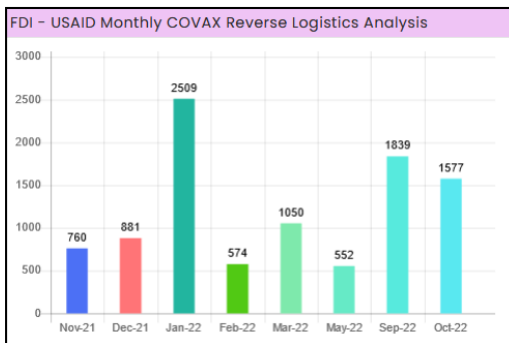
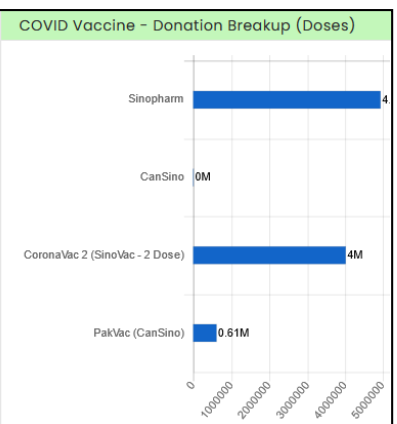
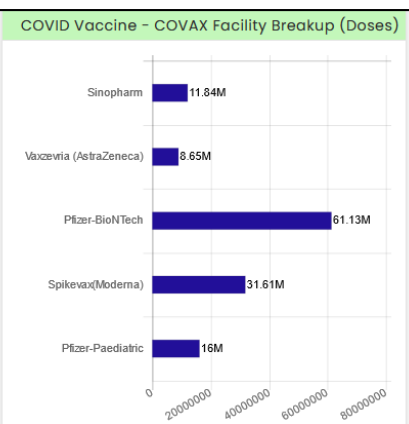
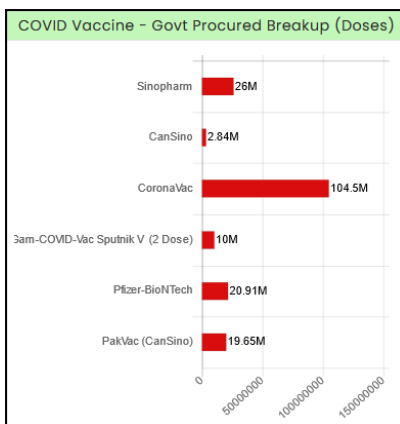
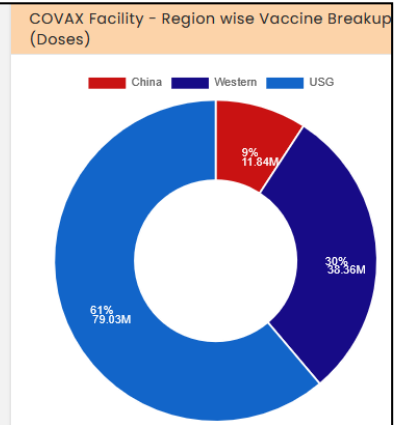
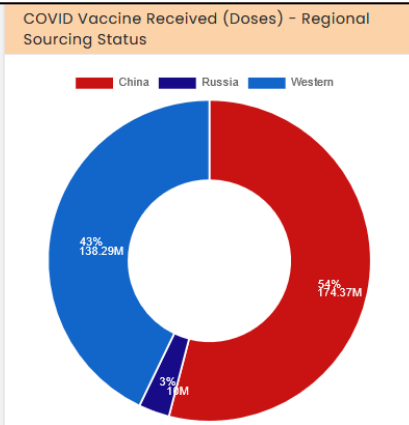
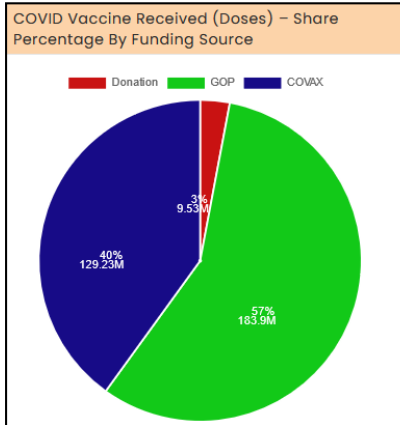

Vaccination Doses Administrated

Total Till Date	
First Dose	139,640,459
Fully Vaccinated	132,307,790
Booster	48,820,154
Total Doses Administrated	320,768,403
Last 24 Hours (Updated on 07-Dec-2022)	
First Dose	2,493
Fully Vaccinated	4,909
Booster	59,838
Total Doses Administrated	67,240

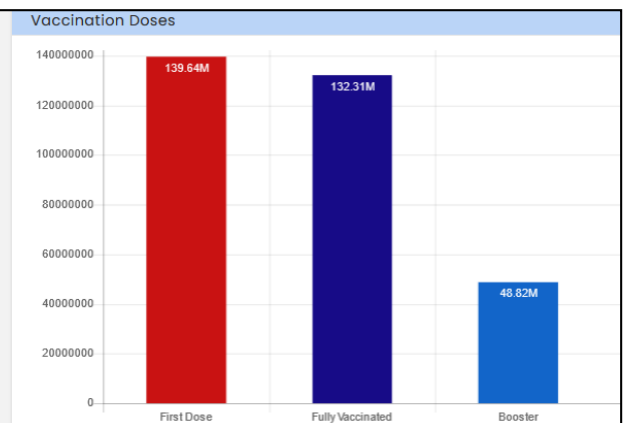

5.3 Reverse Logistics of Pfizer Vaccine

(1) For COVID Pfizer-BioNTech vaccines (Adult and Pediatric), FDI apply Reverse Logistics to return back thermal boxes with Data Loggers to Pfizer for their reuse/recycle purpose as per Pfizer's global contract with donors and governments/countries for vaccine purchase.

Reverse Logistics for Pfizer-BioNTech Soft boxes is very much essential to;

- Avoid any misuse
- Secure temperature device with data i.e., Data Loggers
- Reuse / Recycle Purpose
- Secure manufacturer's Intellectual Property (IP)



(2) Returning of Real-Time Temperature Monitor and Thermal Shipping Containers to supplier to help Pfizer fulfill its commitment to reusable resources. To prepare the thermal shipping container for return, following guidelines should be followed based on standard operation procedure provided by the manufacturer:

- Upon arrival of Pfizer-BioNTech vaccine boxes at the FDI warehouse, all the Data Loggers to be stopped to secure the data and upload the current data on the Pfizer web portal.
- Properly discard the dry ice. Take necessary precautions by reviewing the Dry Ice Safety Data Sheet.
- Remove the remaining dry ice by leaving it at room temperature in a well-ventilated area. It will change from a solid to a gas. DO NOT leave dry ice in an unsecured area.
- Make sure everything to be returned is inside the box, then tape it shut. The return label can be found inside the shipper or already adhered to the inner flap of the thermal shipper.
- Contact the carrier identified on the return label to arrange the return. Followed the Returning Thermal Shipping Container instructions included in the shipper. When coordinating the return of the soft box thermal shipping container, applied the preprinted return shipping label over the existing shipping label.
- The diagram illustrates the process of return of thermal shipper soft boxes:

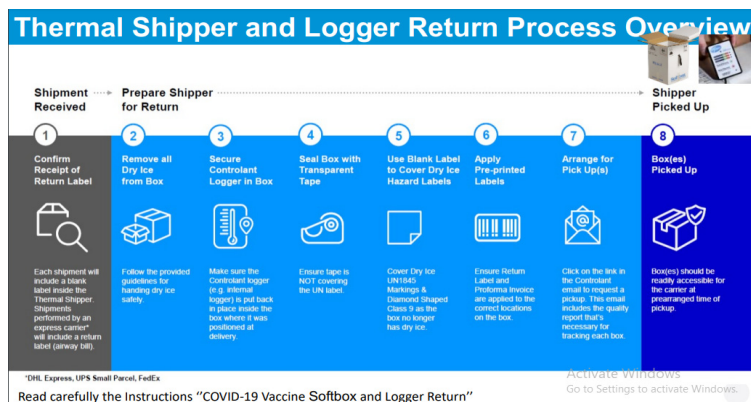

(3) Ensure the Dry Ice UN1845 marking and diamond-shaped Class 9

Elements Required for Return

- Thermal Shipping container and inner components
- Temperature Monitoring Device
- Dry Ice Pod

hazard label on the thermal shipping container are covered by placing a blank label over them in preparation for the return, as the container no longer contains dry ice.

(4) For Soft box, blank sticker labels to place over the UN1845 markings found on the back page of the Shipping and Handling Guidelines.





6. Monitoring and Supervision of Logistics System

No	Description	National		Provincial/Regional		District	Tehsil	EPI Center
		Policy	Operations	Policy	Operations			
5.1	MONITORING AND SUPERVISION OF VACCINES LOGISTICS SYSTEM	✓	✓	✓	✓	✓	✓	✓
5.2	CHECKLISTS FOR FIELD EVALUATION	✓	✓	✓	✓	✓	✓	✓
	Specimen Vaccine Logistics Monitoring Checklists	✓	✓	✓	✓	✓	✓	✓

6.1 Monitoring and Supervision of Vaccines Logistics System

The web based LMIS provides information for the policymakers, planners, district managers, and service providers to ensure smooth functioning of the logistics management system. It provides basic data on available stock, consumption, level of stock in months; and other useful information at the district-, province-, and national-level. The planners and policymakers can use this information for forecasting requirements and budgetary allocations at the national- and provincial-levels. They can also monitor the stock availability situation at various levels, including the federal and provincial Warehouse. The managers at the national-, provincial-, and district-level can use the information generated through web-based LMIS for monitoring stock availability situations (i.e., stock outs, overstocking, understocking, expired/damaged stock, etc. at the district level and to correct the situation). The district manager can also use this information for adjustment/transfer of the stock from surplus districts to deficient districts by monitoring the stock availability through the web based LMIS.

Continuous monitoring of the logistics system is required to indicate/analyze how well the system is functioning and it identifies areas that require further investigation. Each level of the warehouse needs to be visited periodically to determine if sufficient quantities of vaccines are available and to evaluate the storage conditions and logistics-related record.

The objectives of monitoring and supportive supervision of the logistics at district- and health-facilities are to—

- Ensure the availability of sufficient stocks of vaccines at all levels
- Correct the problems, which could be solved on the spot without involving the upper-level management
- Provide on-the-job (OJT) to the logistics staff, if needed



The desk monitoring of the vLMIS reports is an essential and routine first step for all supervisors monitoring performance; therefore, supervisors should plan their visits based on the performance of the facilities (or districts) as reported/presented in the web based LMIS.

The LMIS can be accessed at <http://vlmis.gov.pk>.

6.2 Checklists for Field Evaluation

Field monitoring checklists were developed in coordination with the relevant government departments. Using the checklist will facilitate the provincial- and district-level supervisors to check all components of the logistics system and, in addition, check the accuracy of data uploaded in LMIS, thus ensuring data quality. The monitoring staff is encouraged to ask questions outside the checklist to identify the logistics related issues/problems and to gather all the necessary information, keeping in mind the current situation. The staff must keep the managers at all levels well informed so they can make appropriate decisions to bring about improvement in the system.

Specimen Vaccine Logistics Monitoring Checklists

Logistics Monitoring Checklist for Vaccines at District Stores

District _____ Department (EPI, PPHI, any other): _____

Visit Date _____ Monitoring Officer _____

Name of facility-in-charge _____

Name of store keeper/vaccinator _____

Human Resource	Observation	Comments
Staff designated for running the EPI store?	Yes/No	
i. If sanctioned post _____ ii. Additional charge _____		
Has the designated staff received formal training in storekeeping? If yes, mention date and type of training.	Yes/No	
If yes, what is the exact title of the training:		
* Does the store keeper have basic knowledge of store maintenance? If s/he answers the following four questions correctly, then yes, otherwise no. iii. What is FEFO? iv. How to fill the Bin card? v. What are different components of stock register? vi. What is Issue/Receipt vouchers and how to fill that?	Yes/No	
If yes, has s/he received training on completing all vLMIS forms? If yes, mention date and type of training.	Yes/No	

Storage Conditions

Storage	Observation	Comments
Is cold chain equipment available (ILRs, cold room)?	Yes/No	
If available, is the cold chain equipment functioning?	Yes/No	
The equipment is clean inside and outside.	Yes/No	
Functional voltage stabilizer is available with the equipment.	Yes/No	
Thermostat is working?	Yes/No	
Working thermometer is placed inside?	Yes/No	
Vaccines are stored in the right place in the right way (in baskets not on floor)?	Yes/No	
Vaccines are stored at the right temperature (2°–8°C) at the time of monitoring?	Yes/No	
Only vaccines and diluents are kept inside the equipment?	Yes/No	
Electricity back-up available? (generator/UPS/solar, etc.)	Yes/No	
Electricity back-up functioning?	Yes/No	

Quantities of Stock Observed on the Date of Inspection

S. No	Name of the Item	Quantity Available in the Stock Register	Quantities Physically Verified	Average Monthly Consumption (AMC) ³	Sufficiency in Number of Months ⁴
1	IPV				
2	mOPV1				
3	bOPV				
4	tOPV				
5	tOPV (Campaign)				
6	BCG-20				
7	Pentavalent-1				
8	Pneumococcal-2 (PCV10)				
10	Measles and rubella-10				
11	Measles and rubella-10 (Campaign)				
12	TT-10				
13	TT-20				
14	TT-20 (Campaign)				
15	AD syringe 0.05 ml				
16	AD syringe 0.5 ml				
17	Recon. syringe 2 ml				
18	Recon. syringe 5 ml				
19	Safety box				

³Average monthly consumption (AMC) of last three non-zero months. The formula given as AMC = last three non-zero months/3

⁴ Available stock/AMC

Inventory Control

(Based on observations of vaccine inventory charts and LMIS forms)

Inventory	Observation	Comments
Bin cards available?	Yes/No	
Daily vaccine inventory & temperature monitoring chart maintained (monthly chart) and available?	Yes/No	
Previous month's charts available?	Yes/No	
Are charts properly filled and signed (morning and evening temperature noted)?	Yes/No	
Stock register maintained until date, according to prescribed procedures.	Yes/No	
Does the vaccine inventory chart match the stock register?	Yes/No	
Issue/receipt vouchers files are maintained?	Yes/No	
Are the monthly reports being prepared and submitted regularly?	Yes/No	
Was any product stocked out ⁵ during last reporting month?	Yes/No	

Vaccine Logistics Management Information System (vLMIS)

(to be asked by the vLMIS operator)

vLMIS	Observation*	Comments
Is district vLMIS operator trained?	Yes/No	
Is district vLMIS operator uploading data in vLMIS regularly?	Yes/No	
Is sub-district level vLMIS operator trained?	Yes/No	
Is sub-district level vLMIS operator uploading data in vLMIS regularly?	Yes/No	

*If yes, mention date and type of training.

⁵ If stock is available for less than one month

Comparison of vLMIS with Physical Store Data

Month/Year _____ (In each box write the value listed for the last reported month)

S. No	Name of the Item	Opening Balance		Received		Issuance		Closing Balance		Any Discrepancy Yes/No	Comments
		LMIS	Stock Register	LMIS	Stock Register	LMIS	Stock Register	LMIS	Stock Register		
1	IPV										
2	mOPV1										
3	bOPV										
4	tOPV										
5	tOPV (Campaign)										
6	BCG-20										
7	Pentavalent-1										
8	Pneumococcal-2 (PCV10)										
10	Measles and rubella-10										
11	Measles and rubella-10 (Campaign)										
12	TT-10										
13	TT-20										
14	TT-20 (Campaign)										
15	AD syringe 0.05ml										
16	AD syringe 0.5ml										
17	Recon. Syr 2ml										
18	Recon. Syr 5ml										
19	Safety Box										

Observations, Actions, and Recommendations:

Area	Major Observations/Issues	Action Taken/Recommendation
HR issues		
Storage conditions		
Stock position		
Inventory management		
Use of vLMIS		
Any other		



References

- Government of Pakistan (GOP). 2022. National EPI Policy and Strategic Guidelines Pakistan 2022. <https://phkh.nhsrsc.pk/sites/default/files/202204/National%20Immunization%20Policy%20Pakistan%202022.pdf>
- United States Agency for International Development (USAID). 2003. Immunization Essentials: A Practical Field Guide. Washington, DC: USAID.
- World Health Organization (WHO) Department of Immunization, Vaccines and Biologicals. 2014. WHO Policy Statement: Multi-dose Vial Policy (MDVP) Handling of Multi-Dose Vaccine Vials After Opening. Geneva: WHO.
- World Health Organization (WHO). 2021a. Health Topics—Vaccines. <http://www.who.int/topics/vaccines/en/>
- World Health Organization (WHO). 2022b. Immunizations, Vaccines and Biologicals. Hepatitis B. <http://www.who.int/immunization/diseases/hepatitisB/en/>
- World Health Organization (WHO). 2023c. Immunizations, Vaccines and Biologicals. IPV Introduction, OPV Withdrawal and Routine Immunization Strengthening. http://www.who.int/immunization/diseases/poliomyelitis/endgame_objective2/en/
- World Health Organization (WHO). 2023d. Immunizations, Vaccines and Biologicals. Training for mid-level managers (MLM) Module 1. <http://www.who.int/immunization/documents/mlm/en/>



APPENDIX

No	Description	National		Provincial/Regional		District	Tehsil	FDI/EPI Center
		Policy	Operations	Policy	Operations			
A	Terms of Reference for the Condemnation Committee	✓	✓	✓	✓			
B	Logistics Management Responsibilities	✓	✓	✓	✓	✓		
C	Common Logistics Problems, Causes, and Examples of Possible Solutions	✓	✓	✓	✓	✓		
D	Warehouse Staff Job Descriptions	✓	✓	✓	✓			
E	FDI/EPI Staff Health and Safety	✓	✓	✓	✓			
F	Standard Operating Procedures	✓	✓	✓	✓			
G	Warehouse Monitoring and Evaluation Checklist	✓	✓	✓	✓			
H	How to use ILR Urdu					✓	✓	✓



Appendix – A: Terms of Reference for the Condemnation Committee

1. The committee will examine the vaccines identified as date expired/unusable and determine if they are actually unusable. The committee will advise, in writing, that these items can be destroyed with the approval of competent authority.
2. To condemn the unusable vaccines, a proposal with a copy of the condemnation committee meeting proceedings will be sent to the competent authority and request his approval.
3. After the approval of competent authority, another meeting of the committee will be convened to destroy the approved unusable vaccines.
4. The committee will prepare a report after the destruction takes place. This report or certificate of disposal will indicate—
 - The item destroyed, including its quantity
 - Date and place of destruction
 - Method of destruction
 - Each Committee member will sign the report.
5. The committee will ensure that the disposal of unusable items has been undertaken in accordance with the Environmental Protection Agency (EPA) regulations.
6. The certificate will be prepared in triplicate. The original will be sent to the FDI program manager and a copy will be retained in the record of the concerned unit.
7. The certificate of destruction will be the basis for writing off the destroyed quantity in the stock register.



Appendix – B: Logistics Management responsibilities

In a logistics management system, the relevant staff plays a vital role in making the system successful. In Pakistan, a number of operational tiers manage the vaccines logistic system at central- and provincial-warehouse, and district-, and health-facility levels. Table 10 shows various tiers and staffing in the logistics management system:

Table 10. Key Logistics Staff at Various Levels

LEVELS/ TIERS	OFFICIALS
At FDI cell, Islamabad level	Director warehouse Store supervisor Store keeper (SK)
At provincial level	EPI vaccines store-in-charge Dry store-in-charge
At district level	Store-in-charge
At facility level	Medical officer/vaccinator

Logistics Management Staff, Role and Responsibilities

The roles and responsibilities at various levels to manage the logistics system are given in the following tables (see table 11, 12, and 13):

Table 11. Responsibilities of Federal, Provincial, and Regional Logistics Officer/Store-in-Charge and Designated District Logistics Officers

Responsibility	Task
1. Receiving	<ul style="list-style-type: none"> Ensure that the store keeper(s) receive all vaccines according to the quantity mentioned in the invoice/voucher. Ensure that all vaccines received are in good condition. Ensure that the vaccines received from the suppliers have adequate shelf life. Ensure that the invoice/voucher is properly signed by the SK and countersigned by the designated authority.
	<ul style="list-style-type: none"> Ensure that all vaccines are stored in the proper specified cold chain equipment. Ensure that the SKs follow the storage guidelines strictly in running the warehouse. Ensure that vaccines are arranged following the FEFO principle.
2. Storing	<ul style="list-style-type: none"> Ensure that storage space is allocated according to efficient store layout principles.
3. Issuing	<ul style="list-style-type: none"> Ensure that the SK uses the stock register properly. Ensure that the SK determines issue quantity so the recipients can maintain inventory at the maximum-minimum stock level. Ensure that the SK prepares the issue/receipt vouchers.

Responsibility	Task
	<ul style="list-style-type: none"> • Ensure that the SK issues vaccines following the FEFO principle. • Ensure that the SK follows the supply scheduling in supplying vaccines. • Ensure that SK correctly maintains the copies of issue/receipt vouchers.
4. Recording	<ul style="list-style-type: none"> • Ensure that the SK maintains the stock register for recording transactions. • Ensure that the SK records vaccines in the stock register. • Ensure that stock register is up to date. • From time to time, check the stock register to ensure that these are maintained correctly and properly.
5. Disposing Unusable	<ul style="list-style-type: none"> • Ensure that the SK prepares a list of unusable vaccines of his warehouse and informs the supervisor in time. • As member-secretary of the condemnation committee, place the file to the authorities for their consent to convene a meeting of the condemnation committee. • Issue notice of meeting to the condemnation committee members at least one week before the meeting. • Prepare the proceedings of the meeting, obtain signatures of the members present in the meeting and send proposal in the prescribed form to the competent authority to get their approval for condemnation. • Condemn all the approved unusable commodities of his warehouse in the presence of the condemnation committee members. • Ensure that the SK has recorded all the condemned commodities properly in the stock register and reported them correctly in the monthly report.
6. Monitoring and Supervision	<p>As head of the Warehouse;</p> <ul style="list-style-type: none"> • Routinely monitor the activities of the warehouse staff to ensure that each individual staff completes his assignment, as per schedule. • Supervise the employees to ensure that they have the correct knowledge and skills required to perform their assignments. • Provide OJT if any knowledge and skill deficiency is identified. • Provide supportive supervision to the staff.
7. Reporting	<ul style="list-style-type: none"> • Regularly review reports received from the lower level and send feedback if there are any mistakes or give suggestions for improvement. • Ensure that the SK prepares all reports on time and submits for review and approval. • Review and approve reports prepared by the SK and ensure that reports are mailed to the appropriate authorities on time.
8. Conducting Physical Verification	<p>As member–secretary of annual physical verification committee,</p> <ul style="list-style-type: none"> • Convene meeting of the committee to conduct annual physical verification of warehouse. • Ensure that the members receive notice at least one week prior to conducting the physical verification. • Notify the facilities that receive commodities from the warehouse that during physical verification, there will be no transaction of commodities. • If a discrepancy is identified during physical verification, make the necessary adjustment following the prescribed procedures.

Responsibility	Task
	<ul style="list-style-type: none"> • If any new unusable vaccine is identified during the physical verification, segregate the unusable from the usable and store them at a place marked for unusable. Properly record the unusable in stock register and other relevant forms. • Use the physical verification instrument to record finding of physical inventory and obtain signatures of committee members. • Report findings of physical verification to the appropriate authorities. • Preserve a signed copy of physical verification instrument in the file for record. • Ensure that the SK regularly conducts sample physical verification and keeps the authorities informed on the findings.

Table 12. Responsibilities of Store Keeper

Responsibility	Task
1. Receiving	<ul style="list-style-type: none"> • Receive all commodities ensuring that the quantity mentioned in invoice/voucher is delivered. • Ensure that all commodities received are in good condition. • Bring to the notice of the designated officer-in-charge if any vial is broken or damaged, or if there is any shortage or excess. • Ensure that the vaccines received have adequate shelf life. • Sign copies of invoice/voucher that are sent with commodities and bring them to the designated officer-in-charge for counter signatures. • Return the countersigned copies of invoice/ voucher to the supply source. • Preserve the first copy of invoice/voucher in the warehouse.
2. Storing	<ul style="list-style-type: none"> • Allocate and mark the storage space according to efficient store layout principles. • Place storage cabinet/shelves and equipment at the marked places for different commodities. • Arrange vaccines following the FEFO principle. • Operate the warehouse following the storage guidelines. • From time-to-time, conduct sample physical verification, once a year complete physical verification to be sure that the book balance and physical balance match each other. • Adjust discrepancies, if any, with the approval of the designated officer following procedures and update records.
3. Issuing	<ul style="list-style-type: none"> • Review vaccines requisition forms received from the lower level to examine and determine the issue quantity. • Present the requisition forms to the designated officer-in-charge for review and approval. • Enter the approved quantity. • Issue vaccines following FEFO principle. • Preserve the acknowledged copies of vaccines requisition forms in the warehouse.

Responsibility	Task
4. Recording	<ul style="list-style-type: none"> • Maintain stock registers to record all transactions for all vaccines. • Use computer codes given for each item, if any. • Update stock register after every transaction. • Record transferor disposal of unusable vaccines in the remark's column of the stock register. • Use different ink while recording transfer or destroying of unusable vaccines in the relevant columns of the stock register. • Periodically take the stock register to the designated officer-in charge for review and making necessary comments.
5. Handling Unusable	<ul style="list-style-type: none"> • Report immediately to the designated officer-in-charge if any vaccine in the warehouse is identified as unusable. • Using issue voucher, separate unusable from the usable stock, with the approval of the designated officer-in-charge. • Store the unusable stock at a place marked for unusable. • Use different ink to record transactions of unusable commodities in relevant columns of stock register. • Assist the designated officer to condemn unusable. • Report condemnation of unusable through monthly report forms.
6. Reporting	<ul style="list-style-type: none"> • Upload the vaccines consumption data into web based LMIS by 10th of each month.
7. Requisitioning	<ul style="list-style-type: none"> • Prepare monthly/quarterly requisition, using prescribed Form B. • Obtain the approval of manager. • In case of health facility, prepare the monthly requisition on the prescribed Form B for submission to the concerned UC/district office.
8. Conducting Physical Verification	<ul style="list-style-type: none"> • Regularly conduct sample physical inventory so that all the items are covered within the year. • Reorganize store, if needed, to ensure FEFO. • If a discrepancy is identified, adjust records with prior approval of the designated officer-in-charge. • If any new, unusable vaccine is identified during physical verifications, immediately segregate it from usable vaccines and store it at the place marked for unusable. • Update stock registers.
9. Maintaining Quality Assurance	<ul style="list-style-type: none"> • Follow the storage guidelines in operating the store. • Store vaccines following FEFO. • Record manufacturing and expiry date in the stock register. • Issue vaccines following FEFO principle. • Prepare list of near expiry vaccines and, with approval of the designated officer-in-charge and supply source, supply the vaccines to the facilities before the expiry of shelf life. • Return to supply source vaccines that cannot be used with the shelf-life period locally. • Always keep the store clean so that it will be free from insects, bugs, etc. • Regularly disinfect the store. (It needs to be done using guidelines from the experts.)

Appendix – C: Common Logistics Problems, Causes, and Examples of Possible Solutions

Table 13. Common Logistics Problems, Causes, and Examples

Problem	Probable Causes	Possible Solutions
Undersupply	<ul style="list-style-type: none"> Poor forecasting Inaccurate or incomplete count of products on hand Seasonal increase in product use Slow administrative procedures Failure to move products rapidly Inadequate or infrequent supply 	<ul style="list-style-type: none"> Improve data used for forecast Review inventory control procedures. Adjust subsequent issue quantities; transfer product from low-use areas. Improve receipts and inspection procedures. Streamline distribution procedures; seek alternate transport. Find alternate source of supply.
Oversupply	<ul style="list-style-type: none"> Poor forecast Inaccurate or incomplete counts of products on hand Seasonal decline in product use Decline in product use due to user preference Administrative bottlenecks Failure to move products rapidly to facilities Same product now available from other sources 	<ul style="list-style-type: none"> Improve data used for forecast. Review inventory control procedures. Adjust subsequent issue quantities; transfer products to high-use areas. Train staff to deal with side effects and propaganda. Streamline official procedures. Transfer products to areas of high use. Improve coordination with line organizations; investigate why clients or patients use other sources.
Expired stock	<ul style="list-style-type: none"> Oversupply Failure to use oldest products first Accepting products at or near expiration date Nonuse due to deteriorating packaging 	<ul style="list-style-type: none"> See the solutions for oversupply above. Implement first-to-expire, first-out procedures; improve warehouse practices. Implement policy that products must have a minimum shelf life remaining when received. Improve storage and shipping procedures; reduce handling; and use damaged items for training; implement policy to refuse delivery of damaged products.
Damaged stock	<ul style="list-style-type: none"> Improper handling 	<ul style="list-style-type: none"> Give warehouse staff feedback; increase supervision to improve handling procedures; reduce handling; encourage supply transactions in lot sizes.

Problem	Probable Causes	Possible Solutions
	<ul style="list-style-type: none"> • Improper storage • Inadequate packaging • Poor shipping practices 	<ul style="list-style-type: none"> • Review policies on proper storage of supplies with warehouse personnel and increase supervision; repair/renovate storage facilities; reduce product exposure to light, water, chemicals, and pests. • Specify type of packaging that supplier should use; use better materials for repacking. • Improve shipping conditions; seek alternate transportation.
Stock records disagree with physical inventory	<ul style="list-style-type: none"> • Incorrectly recorded receipts and issues and faulty arithmetic • Delayed entries • Use of improper count units • Failure to conduct physical inventories frequently enough • Same products stored in different locations • Theft and pilferage 	<ul style="list-style-type: none"> • Promote care in recording entries and doing computation; simplify forms and records; provide refresher training for staff. • Encourage prompt entries and checking of all transactions. • Implement policy that everyone uses the same units (e.g., cycle of pills). • Ensure that inventories are conducted periodically; provide funds to conduct inventories. • Consolidate same products in one location. • Improve security.

Appendix – D: Warehouse Staff Job Descriptions

Designation: Procurement Officer (BS-16)

Essential Duties and Responsibilities:

- Collaborate with program managers and other stakeholders to develop procurement plans aligned with the FDI's goals and objectives. This involves analyzing procurement needs, conducting market research, and identifying potential suppliers.
- Responsible for Identifying and evaluating potential suppliers, issuing requests for proposals (RFPs) or invitations to bid (ITBs), and managing the bidding process. This includes conducting supplier assessments, negotiating contracts, and establishing long-term relationships with reliable suppliers.
- Responsible for drafting and reviewing contracts and agreements for procurement activities, ensuring compliance with relevant laws, regulations, and organizational policies. Monitoring contract performance, managing variations, and addressing any contract-related issues that may arise.
- Responsible for overseeing the execution of procurement activities, including issuing purchase orders, coordinating with suppliers, and monitoring delivery timelines to ensure timely and accurate fulfillment of orders.
- Responsible for conducting price and cost analysis to ensure competitive pricing and value for money. Comparing prices, evaluating quotations and proposals, and negotiating favorable terms and conditions with suppliers.
- Responsible for maintaining accurate procurement records and documentation, including purchase requisitions, contracts, purchase orders, and supplier information. Ensuring compliance with record-keeping requirements and facilitating audits, as necessary.
- Responsible for identifying and assessing procurement risks, such as supply chain disruptions, quality issues, or regulatory compliance. Developing risk mitigation strategies and implementing measures to minimize potential risks and ensure continuity of procurement operations.
- Responsible for ensuring adherence to procurement policies, procedures, and ethical standards. Promoting transparency, fairness, and accountability in procurement processes, and conducting regular internal reviews to identify and address any irregularities or non-compliance.
- Responsible for monitoring supplier performance and conducting periodic evaluations to assess their adherence to contract terms, quality standards, and delivery schedules. Taking appropriate actions, such as performance improvement plans or supplier performance reviews, based on evaluation outcomes.

- Responsible for collaborating and communicating effectively with internal stakeholders, such as program managers, finance department, and storekeepers, to align procurement activities with program needs and priorities. Providing regular updates on procurement status, potential risks, and opportunities.
- Responsible for identifying opportunities for process improvements, efficiency gains, and cost savings in procurement operations. Implementing best practices, leveraging technology solutions, and participating in professional development activities to enhance procurement skills and knowledge.

Designation: Store Keeper (BS-11)

Essential Duties and Responsibilities:

- Supervise and assist in daily warehouse activities, including filling and shipping vaccines and supplies, based on requisitions from the provinces and districts.
- Ensure the accuracy of vaccines and supply shipments, including the supporting documentation; the stock register; receiving incoming supplies; and routing to the appropriate area or cold rooms using the WMS/vLMIS allocated location.
- Package, assemble, and prepare a dispatch load plan for the requested vaccines and supplies.
- Ensure the vaccines in the refrigerator/freezer rooms are maintained at the set temperature protocols.
- Report to the refrigeration engineer immediately if any excessive heat or cold temperature from the cold chain and refrigeration-air-conditioning system is noticed.
- Prepare the load plan for vaccines and supplies using the requested quantities of provinces and district counterparts; ensure the truck driver/freight forwarders follow the proper vaccine transportation protocols.
- Ensure that vaccines and supply inventory transactions are accurately logged into the WMS/vLMIS; monitor the vaccines and supplies count; and reconcile the activities after dispatching to the provinces and districts.
- Using a barcode scanning device, ensure that helpers are scanning vaccines that have a barcode by their lot, shelf, and location.
- Measure and report on the effectiveness of warehouse activities for the additional resources or equipment, if required.
- Maintain all the required stationery and equipment to ensure efficient work at the warehouse.
- Develop and maintain warehouse work instructions for all tasks for the laborers, helpers, and stacker operators working in the warehouse.
- Meet the warehouse objectives, based on the warehouse policy, procedures, and workflow; establish and update work procedures for all staff working in the warehouse.
- Provide training on warehouse policies and procedures for workers; implement safety regulations and cold chain supply chain protocols.

- Recommend measures to the assistant store officer for improving the quality of service, increasing the efficiency of the warehouse work crew, and maintaining the equipment performance, and maintenance.
- Use OJT to continuously improve warehouse operations.
- Coordinate with other warehouse departments to increase cooperation, while performing the activities of the departments.
- Review and analyze the vaccines and supplies provincial and district counterparts' demands/requisitions; prepare an approval sheet for the store officer for approval and release of the vaccines and supplies.
- Coordinate with the customs authorities, freight forwarders, and consignee for the shipments of vaccines and supplies; advise relevant staff about preparing the required documents and letters for releasing the shipments.
- Closely monitor the warehouse building safety, security, and vaccines commodities shelf life; dispose of expired vaccines, in accordance with the Warehouse disposal policy.

Designation: Refrigeration Engineer (BS-17)

Essential Duties and Responsibilities:

- Diagnose and fix any faults and problems with the cold rooms, refrigerators, and cold chain air-conditioning equipment in the Warehouse.
- Be aware of the current condition of running parts, equipment off all cold rooms, refrigerators, and cold chain air conditioning systems.
- Responsible for forecasting future cold chain air-conditioning spares requirements and defect anticipation of any major and minor equipment or parts of the cold chain air-conditioning system.
- Develop and implement a proper cold chain air-conditioning maintenance management plan.
- Develop and implement the cold chain air-conditioning system KPIs; set its performance evaluation mechanism.
- To improve the cold chain system, develop tools of responsibility and accountability for the staff who directly or indirectly are involved in the cold chain air-conditioning system.
- Conduct periodic audits of cold chain air-conditioning system equipment, operations, and maintenance work.
- Respond to and troubleshoot the cold chain temperature data transmission unit.
- Work with the administration department for strategic purchases of generators, reefers, compressors, automobiles, and parts, etc., for prompt ordering.
- Maintain the spare stock of the essential equipment, parts of the cold chain air-conditioning system, to be able to respond to any urgent troubleshooting and defect of the equipment, or part of the cold chain system.

- 
- Advise the National Programme Manager FDI about further improvements in temperature-sensitive logistic and supply chain solutions; to improve the effectiveness and efficiency in the cold chain system, this may require policy-level decisions and administrative arrangements.
 - Program and install data logging instruments and temperature control systems.
 - Inspect and audit the transport cold chain refrigeration system and automation.
 - Provide technical support and technical service to staff that are managing cold chain vaccines and medicines.
 - For optimum performance, manage and coordinate the team of cold chain system technical staff.

Designation: Assistant Refrigeration Engineer (BS-16)

Essential Duties and Responsibilities:

- Improve the operation and balance the required temperature for the unit's refrigeration and cold chain air-conditioning systems.
- Develop and implement the inspection criteria for the cold chain and air-conditioning system; report the performance of cold chain and air-conditioning system to the refrigeration engineer.
- Prepare technical specifications for defective parts or equipment for the cold chain and air-conditioning system; inform the refrigeration engineer to ensure timely purchase of required parts or equipment.
- Inspect, troubleshoot, test, and install new parts for the refrigeration system, air-conditioning system, and associate apparatus.
- Carry out periodic preventive and corrective maintenance for the cold chain and air-conditioning system.
- Ensure that all safety measures are taken during the maintenance work of the cold chain and air-conditioning system.
- Carry out weekly, monthly, and yearly cold chain and air-conditioning system repair and maintenance, report improvements, issues, and suggestions to the refrigeration engineer.
- Provide training on how to maintain an effective cold chain and air-conditioning system to the staff that directly or indirectly manage the cold chain and supplies.
- Develop cold chain and air-conditioning system safety, security, and maintenance pictogram; post at a central location where all the staff can see and/or read.
- For effective, efficient, and smooth functioning of the cold chain operations, provide OJT to all staff who work in the store and who manage the cold chain.

Designation: Sub Engineer (Electrical) (BS-14)

Essential Duties and Responsibilities:

- Review the existing Warehouse electrical control panel design and load capacity; determine if any improvements are required. Repair and replace any defect of the electrical accessories, panels, sockets, and wires installed in the Warehouse.
- Be responsible for complete testing, troubleshooting, and commissioning anything pertinent to the Warehouse electrical system.
- Resolve technical issues/complaints from the warehouse staff about any electrical fault or replacing any accessories for the electrical system.
- Provide full support to the Warehouse for a sufficient electrical supply, per the requirement of cold chain system machines.

- Ensure that only good quality sockets, joints, cables, and other electrical accessories are used in the Warehouse.
- Responsible for all Warehouse electrical operations.
- Maintain the standby generators for the cold chains in the Warehouse.
- Supervise all electrical appliances at each staff workstation; facilitate and provide the best electrical solution, per their requirements.
- Install a quality circuit breaker that responds quickly to any trouble shooting of the switchgear.
- Ensure the overall electrical supply of the Warehouse capacity is up to the requirement or determine if it needs additional transformers.
- Install the new required equipment for the internal and external wiring and plumbing system.
- Do a phase sequence test for the transformer and low voltage/high voltage distribution panels.
- Ensure a regular flow of electricity to the cold chain and air-conditioning system, without any break.
- Ensure that a standby solution, uninterruptible power supply, and generators are ready to respond to any multi-hour's loss of electricity.
- Do the earth testing for the existing layout phase load, per the installed cold chain and air-conditioning system.

Designation: Helper (BS-02)

Essential Duties and Responsibilities:

- Store vaccines and supplies in the warehouse to ensure they are orderly and accessible.
- Pack and unpack vaccines and supplies to be stocked on shelves/racks in warehouses or storage yards.
- Identify damaged and defective vaccines and supplies; report to supervisors.
- Clean and maintain vaccines and supplies, tools, equipment, and storage areas to ensure compliance with safety regulations.
- Receive and count vaccines and supply items before picking or/placing them on the racks and shelves in the cold room and in the dry store; inform the assistant store officer if any discrepancy is found.
- Clean and maintain warehouse areas after receiving and issuing consignments.
- Operate all equipment safely and efficiently, according to all relevant warehouse policies and procedures.
- Clean the fork lifter and warehouse machines, as scheduled, or required.
- Ensure that equipment is safely and securely stored.
- Dispose of sewage, according to set policies and procedures.

- Ensure that warehouse buildings and facilities are well maintained.
- Use basic safety equipment—safety helmets, shoes, gloves, and so on—while working.
- Ensure that fire extinguishers are placed in a central location.
- Off-load the shipments from the containers; stack them properly in the allocated areas.
- Using the directions from the assistant store officer, pick pallets from the racks and place them into the container.

Designation: Labor (BS-02)

Essential Duties and Responsibilities:

- Responsible for following the safe handling and picking protocols for vaccines and supplies when receiving and dispatching.
- Load and unload vehicles; follow the instructions from the store officer and assistant store officer for correctly placing the vaccines and supplies.
- While receiving and dispatching, segregate the each batch of vaccine and diluents/droppers in the Warehouse.
- Move stock to receipt area; pick/place the commodities at the allocated location of the WAREHOUSE.
- Responsible for physical counting of each batch after stacking.
- Identify the repackaging and pillarization requirements; repack cartons, if required. Remove/dispose of packing material and store ice packs and coolants from cold store premises.
- Dispose of dry ice, if present.
- To avoid an accident, follow the health and safety precautions while loading and unloading of vaccines and supplies in the warehouse.
- Use all the required personal protective equipment while loading and unloading vaccines and supplies.



Appendix – E: Staff Health and Safety

1. Introduction

The FDI is committed to ensuring workplace safety and security. The purpose of this is to avoid workplace violence and to ensure a safe and healthy work environment for all warehouse staff. To achieve this, a workplace safety and security checklist has been prepared to guide the teams and individuals on how to self-assess their surroundings. This will be beneficial for each warehouse department—store, administration, transport, and finance—to perform a hazard assessment against specific workplace safety and security issues, as indicated in the checklist.

The safety and security checklist assessment helps determine risks for the warehouse employees, supplies, and assets; as well as to evaluate their susceptibility to workplace violence by sharing their findings and observations with the responsible departmental heads or managers. It is the responsibility of every manager to review the checklist and to remove all the safety and security hazards.

2. Compliance Statement

The Warehouse staff health and safety procedures have a zero-tolerance policy for threats of physical harm, intimidation, or any other hostile acts directed toward warehouse employees and supplies. The health and safety procedures encourage immediate help for all employees and departmental managers and supervisors in case of any such incident. The manual also provides guidelines for managers if they encounter anticipated workplace hazards, threats, or violence. The active implementation of the warehouse staff health and safety procedures includes the following steps:

- 1.1 Educate warehouse employees, supervisors, and managers on all staff health and safety procedures; motivate staff to adopt precautionary measures while performing their duties. Supervisors and managers should encourage and counsel staff members to encourage an elevated sense of responsibility toward health and safety in the workplace.
- 1.2 Train and counsel managers, supervisors, and employees who do not comply with the workplace practices listed in the designated health and safety checklist. Managers and supervisors are required to educate their staff and provide OJT in basic health and safety.
- 1.3 Recommend that warehouse senior officers and managers take corrective action for anyone that repeatedly fails to comply with the warehouse staff health and safety procedures and practices.

3. Workplace Violence Classification

While working in the Warehouse, employees are vulnerable to various types of threats that can directly or indirectly endanger their lives.

Described below is a summary of some of the threats that may occur in the vicinity of the Warehouse:

3.1 Personal Assault or Threat:

Personal assault in a workplace may involve the following:

- Employee workplace violence can involve a personal assault or a threat from the workplace condition. For example, employees are attempting to deliver services, as described in their duties, but the environment is not appropriate for them to perform these duties safely and securely
- Pressuring employees to do their job without providing them with adequate safety and security equipment, tools, training, and an appropriate healthy and safe working environment.
- Failing to promote and create a safe and secure working environment is also an assault or threat of violence, as is not paying attention to day-to-day working hazards and their mitigation.

3.2 Employees Harm:

A workplace assault or threat of violence that can harm employees are listed below. They can be caused by—

- An unskilled and inexperienced stacker operator using a forklift; and untrained staff loading and unloading labor.
- Poor construction of the building and old or out-of-order forklifts, racks, stackers, trucks, and vehicles may cause employee workplace harm.
- Untrained truck drivers and traffic accidents during the transport of vaccines and supplies.
- Breaking vials or ampoules can harm the unskilled.

3.3 Fire:

Fire is a major threat of violence in the workplace for employees:

- An inefficient response mechanism: having no fire alarms, firefighting system, and/or no first aid kits.
- Inattention to inadequate and old electrical items, such as uncovered/improperly covered electrical outlets, junction boxes, and other electrical components.
- Improper repairing and maintenance; and improper grounding of extension cords in the warehouse can lead to short circuiting and fire.
- Unavailable fire extinguishers.

3.4 Unsafe Working in Freezer/Cold Rooms:

Following are the risks associated with unsafe working in freezer and cold rooms, which may cause workplace violence:

- Risk of hypothermia if staff is not warmly clothed while working in the freezer and cold rooms.
- Unskilled and untrained staff working in vaccine storage areas.
- Suffocation in confined space of the freezer room/cold room because dry ice is stored; when it evaporates, deadly carbon dioxide gas accumulates.

3.5 Cold Chain Equipment Breakdown:

Cold chain equipment breakdown is also a reason for workplace violence. Main causes may be the following:

- Cold room or freezer room refrigeration unit not working or not cooling.
- Main electrical supply/power failure that may include a problem in with the generators.

4. Responsibility

4.1 Warehouse Managers and Supervisors:

Store staff particularly the store keeper, under the supervision of the store officers and assistant store officers; the refrigeration engineers at the Warehouse are responsible for the following functions:

1. Managers and supervisors, working in various functions in the warehouse, should review all the previous and current incidents to identify repeated threats or violations. After the review, they must take appropriate steps to mitigate and prevent a repetition of the incident or violation.
2. If a situation arises, they should immediately visit the scene of the incident and control the situation, as well as arrange for basic healthcare, based on the need.
3. Physically inspect the site to determine the cause of the incident.
4. Based on an established priority, they should conduct interviews of threatened or injured employees. Additionally, managers must also record the statements of witnesses, collect evidence from the area, and record and report it.
5. Examine the warehouse workplace to determine risk factors associated with the incident. Managers must include any previous reports of inappropriate behavior by the perpetrator, if appropriate, and ensure corrective action is taken.
6. They should take corrective actions to prevent the incident from recurring and should provide all the resources, services, and guidance necessary to change the behavior of the perpetrator.
7. Ensure that the staff health and safety procedures are followed by carefully monitoring employees' compliance with the principles of health and safety procedures.
8. Should coordinate assessment and provide assistance to ensure that the principles of staff health and safety procedures are implemented by following the checklist.

9. Implement and maintain staff health and safety procedures in the work areas of all the sections and departments of the warehouse.
10. Conduct an initial assessment of warehouse staff health and safety procedures, when appropriate, and update the staff health and safety checklist.
11. Evaluate the potential risk factors that are inappropriate for staff health and safety. Moreover, they should give advice on precautions to take against potential threats.
12. Ensure that the work environment is always physically safe and secure by upholding the principles of the staff health and safety procedures checklist.

4.2 Employees

- 4.2.1. All employees should follow the principles of the warehouse staff health and safety procedures checklist as they work; in so doing, they will support a safe and secure working environment to safeguard employees and supplies from potential threats.
- 4.2.2. Each warehouse employee should inform their immediate supervisor of potential risks that may harm themselves or other staff or supplies; and report any workplace violence, or any violation of the principles set forth by the staff health and safety procedures.
- 4.2.3. Each employee of the warehouse should conduct a personal health and safety assessment to identify potential threats to the workplace environment, remembering the warehouse supplies and assets.

5. Reporting

5.1 Employees

- 5.1.1. Employees working in the warehouse should report incidents of threats or acts of physical or direct or indirect harm to supplies and staff.
- 5.1.2. Soon after a report is made, employees must immediately follow up on the incident.

Incident Reporting Form				
Sr. No.	Date/Time	Incident	Reported by...	Reported to...

5.2 Supervisors

- 5.2.1. Managers and supervisors should encourage reporting behavior within the staff and encourage a sense of responsibility toward staff health and safety procedures.
- 5.2.2. They should also create awareness among the staff of the consequences when the health and safety procedures are not followed; and encourage them to identify and report existing potential threats, and anticipated threats, within their areas of work. This will enable the staff to remain responsible, accountable, and vigilant about their surroundings.

6. Communication

- 6.1.1. The Director of the Warehouse should maintain a safe, healthy, and secure workplace environment. The environment must have an open, two-way communication for employees, managers, and supervisors about workplace health and safety and security issues.
- 6.1.2. Staff health and safety procedures and security checklist should encourage a continuous flow of communication between the warehouse management and the employees. The environment should be free from reprisal, fear, or ridicule; and communication must be in an easily understandable form.

Communication that concerns staff health and safety includes the following processes:

- 6.1.3. New employees, subcontractors, transport providers, and donors' delegates should be given a proper orientation to warehouse staff health, safety, and security procedures. They should also be educated on specific rules and principles of staff health and safety, which must be followed.
- 6.1.4. Training programs should address specific aspects of workplace staff health and safety threats.
- 6.1.5. Regular weekly staff health and safety meetings should be included in the workplace security discussions to promote a zero-tolerance philosophy.
- 6.1.6. Warehouse workplace safety and security information should be adequately posted and distributed.
- 6.1.7. Warehouse senior management must encourage the zero-tolerance philosophy among warehouse employees to ensure that employees will promptly report staff health and safety workplace security hazards or threats of violence.
- 6.1.8. Information is provided on procedures for protecting warehouse employees and reporting physical violence or threats of retaliation by the person engaging in unacceptable behavior.

7. Hazard Assessment

- 7.1.1. Staff health and safety hazard assessments should be performed by a documentation review to develop a warehouse security checklist. This can be achieved through periodic interviews with warehouse employees and subsequent warehouse workplace evaluation. The evaluation should incorporate warehouse security hazards and threats related to workplace violence.
- 7.1.2. Periodic inspections should be carried out using the staff health and safety principles checklist, based on the following schedule:

- 7.1.2.1. Conduct a monthly review of the warehouse environs and warehouse working environment; include the tools and equipment that pose high security risks for employees. Also cover the warehouse building, installed racks, pallet condition, and fire extinguishers.
- 7.1.2.2. Conduct a review of previously unidentified health and safety hazard reports to identify precautionary measures used to mitigate those security hazards.

8. Incident Investigation

The following principles are established for investigating incidents at the warehouse related to staff health and safety. These investigations must cover violence or threats of physical injury including the following:

- 6.1.9. A manager or supervisor should review previous safety and security incidents and list the incident type—categorizing why, when, and where it occurred.
- 6.1.10. Visit the scene of an incident as soon as possible.
- 6.1.11. Interview threatened or injured employees and witnesses immediately, collect evidence from the surroundings where the incident occurred.
- 6.1.12. Examine the warehouse workplace for security risk factors associated with any incident; include previous reports of inappropriate behavior by the perpetrator. Appropriate actions against the perpetrator should be taken if negligence or deliberate violation is found.
- 6.1.13. Following form shown below will be used by the manager or supervisors of Warehouse for investigating an incident:

Incident Investigation Form				
Sr. No.	Date/Time	Incident	Reported by...	Remarks

9. Hazard Correction

A hazard threat, if addressed in a timely manner, reduces its severity. For timely actions, a threat should be immediately reported by the first observer. Staff should frequently follow up with the concerned person until the threat is mitigated.

Store staff particularly store keeper under the supervision of health and safety procedures should follow the prescribed warehouse safety checklist leading to prevention and correction of hazards associated.

10. Training, Instruction, and Information

The federal and provincial programs should establish the following principles of training, instruction, and information for all warehouse employees that are pertinent to staff health and safety procedures.

- 10.1. All warehouse employees, including store officers and assistant store officers; refrigeration engineers at Warehouse are responsible for ensuring that staff, are trained on staff health, safety procedures, and the warehouse safety checklist.
- 10.2. Training and instruction are provided to all new employees and to current staff who have not been previously trained. Managers and supervisors should pass on staff health and safety instructions to all suppliers, transport providers, and any other workers who directly or indirectly are involved in the warehouse operations.
- 10.3. Managers and supervisors should receive information on workplace security, violence control, warehouse safety, security principles violations, safe work practices, updated safety checklists, and principles related to staff health and procedures.

The general features of staff health and safety training instruction should incorporate the following:

- 10.4. Clearly explain the health and safety procedures to all staff. Explain the accountability measures for any incident, violent acts, threats, or intentional violations of warehouse safety and security principles.
- 10.5. Recognize health and safety security hazards, which include the risk factors associated with various types of violence; they can come from individual violations of warehouse safety and security principles or negligence of particular alarming threats.
- 10.6. Take necessary measures to prevent warehouse workplace violence, security hazards, or threats, report to the appropriate authority for timely correction and prevention.
- 10.7. Provide information and training for summoning others for assistance during or after the incident.
- 10.8. Provide clear information and instruction on routes of escape in case of a fire.
- 10.9. Provide emergency medical care in the event of any violent act or incident. Moreover, arrange post-event trauma counseling, if requested by staff.
- 10.10. Keep warehouse employees and managers and supervisors aware of the communication and reporting procedures.
- 10.11. Provide training on self-protection and hazard prevention techniques.
- 10.12. Create awareness of indicators that may lead to violent acts and that staff may encounter when performing their duties.

11. Incident Recordkeeping

- 11.1. Records of reported incidents will be maintained at the Warehouse.
- 11.2. Records of the recommendation reports should be documented properly for future references.
- 11.3. Proper documentation of staff health and safety training must be maintained for each warehouse employee. The document should include employee's name and training dates, type of training, and training providers' records. This document should be maintained with the Warehouse.
- 11.4. For all incidents, inspection records, reports, and training documentation are maintained for three years.

12. Warehouse Staff Health Safety and Security Checklist

The store keeper, under the supervision of the store officer and assistant store officer, will be responsible for filling out this checklist on a weekly basis to ensure the staff's health, safety, and security; and to mitigate and prevent a repetition of the incident or violation at the Warehouse.

Table 14. Warehouse Safety and Security Activity Checklist

*NS: Not Sure **NA: Not Applicable

Warehouse Safety and Security Activity Checklist	Evidence	Yes	No	*NS	**NA	CONCLUSION/REMARKS
Are all warehouse exits clearly marked and clear of obstructions (barriers)?						
Are the warehouse aisles clear of storage?						
Are all pallets, racks, and shelving in good condition and undamaged?						
Are all materials stacked properly and not leaning?						
Are all materials secure and not leaning off the edges of the racks?						
Are guardrails (sign of dangerous area) present in areas of overhead storage above offices or platform?						
Do stacker operators get proper training to operate the stacker or forklift?						
Are horns used during backing, blind corners, or other potentially dangerous situations?						
Do forklifts travel at a safe speed?						
Are seat belts worn by operators?						
Are keys removed and forks lowered when forklifts are parked?						
Are stackers charged in a place free from combustibles and with adequate ventilation?						
Are fire extinguishers placed in each area of the warehouse and accessible?						

Warehouse Safety and Security Activity Checklist	Evidence	Yes	No	*NS	**NA	CONCLUSION/REMARKS
Are fire extinguishers checked monthly?						
Are flammable and combustible materials stored in flammable storage cabinets?						
Is there adequate equipment to minimize employee lifting of heavy or awkward objects?						
Are electrical outlets, junction boxes, and other electrical components properly covered?						
Are extension cords in good repair, properly grounded, and so forth?						
Are panel box doors labeled and closed?						
Are individually keyed locks and tags available for lockout/tag-out of equipment?						
Are there equipment-specific lockout /tag-out procedures?						
Is personal protective equipment (PPE); that is, helmets, safety shoes, goggles, masks, and protective suits available?						
Do employees know when to wear PPE?						
Is PPE in good repair?						
Is PPE available?						
Is a first aid kit available in all sections of the warehouse working area?						
Are the warehouse main blower fans in working condition?						



Appendix – F: Standard Operating Procedures

The FDI Warehouse SOPs Manual

INTRODUCTION

Standard operating procedures (SOPs) are process documents that detail how a worker should perform a given task and ensures that all storekeepers, workers, and laborers, under the supervision of the Store Officer and the Assistant Store Officer perform tasks in the same way, which will consistently produce the expected outcomes.

SOPs, used in combination with planned training and regular performance feedback, lead to an effective and motivated workforce.

This manual, Warehouse Standard Operating Procedures, will help the operators and workers at the federal and provincial Warehouse to streamline the vaccine logistics, supply chain, inventory management.

All the staff must adhere to these SoPs in maintaining ISO certified environment for maintaining an ISO certified warehousing environment including storage, distribution, and inventory management.

ISO CERTIFICATION REQUIREMENTS AND PROCESSES

The International Organization for Standardization (ISO) 9001:2008 requires a documented quality management system. General requirements include an organization to establish, document, implement, and maintain a quality management system and continually improve its effectiveness, in accordance with the requirements of this international standard.

Quality management system documentation requires:

- Documented statements of a quality policy and quality objectives.
- A quality manual.
- Documented procedures.
- Documents needed by the organization to ensure the effective planning, operation, and control of its processes
- Records.

ISO 9001:2008 specifically requires the organization to have documented procedures for the following reasons:

- Control of documents.
- Control of records.
- Internal audit.

- Control of non-conforming products.
- Corrective action.
- Preventive action.

An ISO certification will not only ensure that quality is maintained within the premises, but also will establish credibility of its operations locally and internationally.

Receipt Procedure

The Storekeeper, under the supervision of Store Officer/Assistant Store Officer, is responsible for receiving all the vaccines at the Warehouse.

Procedure for Vaccines Purchased from International Resources

Pre-alert shipment intimation

- For vaccines purchased through the international sources, the Warehouse must receive shipment pre-alerts and shipping documents by email or fax at least 10 days prior to the arrival. Documents will include:
 - ✓ Shipping information from procuring agency/freight forwarding agent (Annex 1)
 - ✓ Copy of airway bill (AWB) (Annex 2)
 - ✓ Copy of packing list (Annex 3)
 - ✓ Copy of invoice (Annex 4)
 - ✓ Copy of release certificate (Annex 5)
- Upon the arrival of advance intimations, delivery schedule for the Vaccine Arrival Date (VAD), store keeper will check the documents, and will:
 - ✓ -Check for availability of space and placement of incoming stock in the freezer room/cold room (FR/CR) of the Warehouse Management System/ vaccine logistics management information system (WMS/vLMIS).

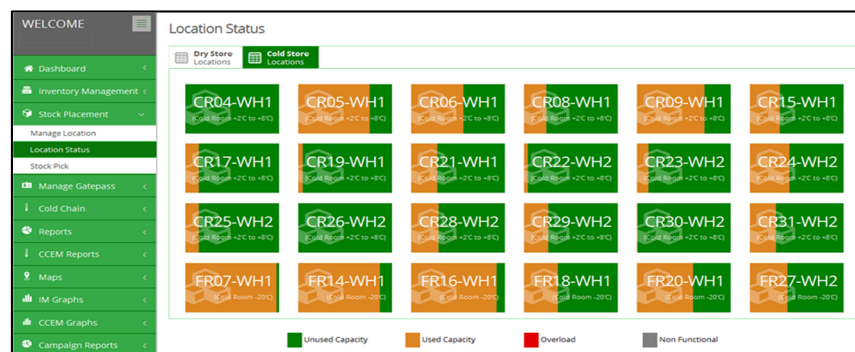

- ✓ Will record the flight arrival details in system as well as in shipping documents, record register and make arrangements for the collection of vaccine from the airport.
- Store officer will appoint a person who will deliver the shipment documents for the pre-appointed clearing agent at the port or airport for custom clearance.

- Will coordinate with the customs clearing agents and prepare the schedule for unloading, after consulting with them.
- Will confirm the readiness to receive vaccines by telephone or email if the airline requires doing so as a condition of delivery.
- Will arrange for the refrigerated trucks to be at the airport in time to collect the vaccine.

Collection of vaccine from the Airport

- Authorized clearing agent will clear the shipment through customs immediately after arrival of the flight and will deliver the shipment to FDI Warehouse preferably within six hours, but not later than 10 hours.
- Nominated FDI Warehouse person will transport the vaccine to the primary store by refrigerated vans and unload the vehicle immediately upon arrival.

Shipment inspection

- Before the inspection, the officer in-charge at the FDI Warehouse must ensure that all vaccines, including those received from international sources, are licensed for use in their country.
- The following documents that accompany the shipment must be checked:
 - ✓ Invoice
 - ✓ Packing list
 - ✓ Lot release certificate for the country of origin/Protocol Certificate (Annex 6)
 - ✓ Vaccine Arrival Report (VAR)-(Annex 7)
- After the vaccines arrive at the FDI Warehouse, unload the refrigerated van, inspect the shipment, and check for physical damage or missing items.
- The following steps must be completed while inspecting the new shipment:
 - ✓ Count the packages according to the packing list.
 - ✓ Segregate each batch of vaccine and diluents/droppers.
 - ✓ Open each carton and stop the electronic shipping indicators (Data Loggers/Q-Tag or similar).
 - ✓ Check the vaccine vial monitor (VVM) status (Annex 8), and type and expiry dates for each type and batch of vaccine.
 - ✓ Perform vaccine Shake Test (Annex 9) to determine whether the vaccine is frozen or not.
 - ✓ Segregate ice packs/coolants from the vaccine and properly store them.
 - ✓ Dispose of dry ice, if received with stock.
- Record the status of VVM stage, type, and expiry date of vaccine in the VAR.

Note: Do not record details of more than one vaccine type on a VAR. A separate VAR form must be completed for each vaccine—e.g., one for oral polio vaccine (OPV), one for Bacillus Calmette-Guérin (BCG), etc.

- Check the status of the electronic shipping indicators. Record the details of any alarms on the Electronic Device Alarm Report form (Annex 10).
- If there are no electronic shipping indicators, check the status of the cold chain monitoring (CCM) cards and record any color changes on the CCM card. Make a photocopy or scan the card; record the color change details and ensure its usability under WHO/ manufacturer guidelines.

For diluents that accompany reconstituted vaccines, such as BCG or measles and rubella vaccine check the batch number, expiry date; and confirm that they comply with the order requirements.

- For droppers, in the case of oral polio vaccine, check a sample of the products to confirm that they comply with the order requirements.
- Record all other required details for each vaccine in the shipment on the VAR form supplied for that vaccine.
- Hand over a copy of the VAR to the procurement agencies office within 72 hours of the flight's arrival.
- For each received shipment, of vaccine, a separate checklist is filled out for reporting and record keeping, as shown below:

Received Shipment Checklist

Date	Purpose	Antigen	Batch No	Manufacture	Received From

Stock placement

If no problems are identified, and the vaccine is accepted, unpack the shipping containers and place the vaccine in the cold chain (FR/CR, refrigerator, or freezer). Place the diluents in the diluent dry store. After physically stacking vaccines in the cold chain, enter the received vaccine quantity in the Stock Receive Form of the vLMIS as shown below and place them into the designated FR/CR in the vLMIS, as already mentioned above.

Stock Receive (Supplier)

Fill out this form

Receipt No.	Ref No. *	Received From (Funding Source)*	Received Time
<input type="text"/>	<input type="text"/>	GAVI	20/01/2023 02:12 PM
Purpose *	Product *	Used for	Manufacturer *
Routine	Select	<input type="text"/>	Select
Batch No. *	Production Date	Expiry Date *	Unit Price per dose (PKR) *
<input type="text"/>	<input type="text"/>	<input type="text"/>	<input type="text"/>
Quantity *	VVM Type *	VVM Stage *	Placement Location *
<input type="text"/>	Select	NA	Select
Vials			

Add Stock Receive

The following points must be filled in the Stock Receive Form of the vLMIS:

- Reference number
- Received from
- Purpose
- Name of vaccine/product
- Manufacturer of the vaccine
- Vial presentation (doses per vial)
- Batch number(s)
- Expiry date
- Quantity of vials received
- VVM type
- VVM stage
- Name of cold chain equipment where the vaccine is kept.
- In case of unusable VVM stage and type or expired vaccine, and if problems or discrepancies are identified, immediately report the concerns to the supplier representative. If problems are identified, do not unpack the vaccine until the problem is resolved.
- Till reaching the resolution, stack the affected shipping container(s), with the temperature monitoring device(s), in holding area of designated FR/CR, as appropriate. Clearly mark each container "DO NOT USE." Place any associated diluents in a designated area of the diluent dry store.
- DO NOT record the arrival in the vLMIS.
- The Store Keeper will retain the VARs and all correspondence relating to the unsatisfactory shipments or procedures for a minimum period of 5 years.

Vaccine Inventory Management

The Store Keeper, under the supervision of the Store Officer/Assistant Store Officer, is responsible for the vaccine inventory management.

Procedure

- Ensure that all receipts and the dispatched transaction of the vaccine stocks are recorded in the WMS/vLMIS or in the stock register, on a daily basis.
- No transactions can be made outside the vLMIS and no supplies can leave the store without an Issue and Receipt Vouchers (IRVs) generated by the vLMIS.
- Ensure that full details of all transactions are completely entered immediately, as they occur.
- To identify the status of inventory for each vaccine, ensure that all vaccine stock has stock cards and bin cards updated and placed in front of each vaccine lot or batch.
- Physically compile and reconcile the dispatched and received vaccine stock in the FDI Warehouse with the quantities reflected in the WMS/vLMIS or stock register.
- Ensure that the vaccine commodities information on the WMS/vLMIS, or stock register, reconciles with the physical stock, location, rack, and pallet.
- Physically monitor and check all vaccines for the name, location, rack, pallet, lot, and batch; and, ensure they are correctly identified in the WMS/vLMIS or stock register.
- Identify and correct any incorrect entries in the FR/CR location, rack, and pallet, and in all areas of the warehouse.
- Manually prepare and record the dispatched and received vaccine commodities on a daily basis and report it in the WMS/vLMIS or in the stock register.
- Stock records, such as IRVs, must be up to date in the vLMIS. Data files must be backed up on a daily basis and the backup media must be kept in a safe place.
- To obtain prints of the vaccine stock sufficiency reports and reviews, have the relevant FDI Warehouse authority sign them and file them.
- Identify and take precautionary measures to safeguard vaccine stock from loss, theft, damage, and expiry.
- Ensure that all features of the WMS /vLMIS are working appropriately and are error free and that any problems that occur with the WMS/vLMIS are reported immediately.
- Ensure that all the WMS/vLMIS equipment is running smoothly, and that it is kept and maintained in good condition.
- Ensure that all vaccine commodities placed in the FDI Warehouse are scanned and arranged by location in each FR/CR.
- Ensure that the vaccine and supplies commodities are released based on the First to Expire, First-Out (FEFO); and that any short expiry is reported immediately to management.

DRY STORE

The Store Keeper, under the supervision of the Store Officer/Assistant Store Officer, is responsible for receiving all ancillary supplies at the FDI Warehouse. Supplies in dry store contain syringes, safety boxes, vitamin capsules, refrigerators, freezers, cold boxes, and vaccine carriers etc.

Shipment Pre-alert

- The FDI Warehouse must receive pre-alert shipment intimation and documents by 10 days before the supplies arrival.
- Get delivery schedule for Product Arrival Date (PAD); and prepare proper logistics and administrative arrangement in advance.
- Check available space and plan placement of incoming stocks and update in vLMIS as shown below:

The screenshot displays the 'Location Status' interface in the vLMIS system. The interface includes a sidebar with navigation options like 'Dashboard', 'Inventory Management', 'Stock Placement', and 'Manage Location'. The main content area shows a 'Location Status' section with tabs for 'Dry Store Locations' and 'Cold Store Locations'. Below the tabs, there are dropdown menus for 'Store*' (set to 1) and 'Row*' (set to A). A 'Show Status' button is visible. The main area contains a grid of storage locations, each represented by a green cell with a unique alphanumeric code. The grid is organized into three main sections: 1A, 1B, and 1C, each with five rows and six columns. The codes are as follows:

Section	Row	Col 1	Col 2	Col 3	Col 4	Col 5	Col 6
1A	1A	1A1A1	1A1A2	1A2A1	1A2A2	1A3A1	1A3A2
	2A	1A1A3	1A1A4	1A2A3	1A2A4	1A3A3	1A3A4
	3A	1A1A5		1A2A5		1A3A5	
	4A	1A4A1	1A4A2	1A5A1	1A5A2	1A6A1	1A6A2
	5A	1A4A3	1A4A4	1A5A3	1A5A4	1A6A3	1A6A4
1B	1B	1A1B1	1A1B2	1A2B1	1A2B2	1A3B1	1A3B2
	2B	1A1B3	1A1B4	1A2B3	1A2B4	1A3B3	1A3B4
	3B	1A1B5		1A2B5		1A3B5	
	4B	1A4B1	1A4B2	1A5B1	1A5B2	1A6B1	1A6B2
	5B	1A4B3	1A4B4	1A5B3	1A5B4	1A6B3	1A6B4
1C	1C	1A1C1	1A1C2	1A2C1	1A2C2	1A3C1	1A3C2
	2C	1A1C3	1A1C4	1A2C3	1A2C4	1A3C3	1A3C4
	3C	1A1C5		1A2C5		1A3C5	
	4C	1A4C1	1A4C2	1A5C1	1A5C2	1A6C1	1A6C2
	5C	1A4C3	1A4C4	1A5C3	1A5C4	1A6C3	1A6C4

- The following must be checked in the shipment, pre-alert documents:
 - ✓ Shipping notification from freight forwarding agent to concerned FDI Warehouse staff
 - ✓ Copy of packing list
 - ✓ Copy of invoice
- Check these documents and file them in the product arrival file.
- FDI Warehouse concerned authorities will deliver the shipment documents for the pre-appointed clearing agent at the port or airport for custom clearance.
- Closely coordinate with the customs clearing agent and prepare the schedule for unloading.

Collect Shipment from the Port of Entry

- Clear the shipment through customs within maximum allowable period preferably less than 24 hours of flight arrival.
- Transport the products to the store or warehouse and immediately unload the vehicle.

Shipment Inspection

- Inspect the shipment when it arrives at the FDI Warehouse and check for physical damage or missing items.
- Check following documents accompanying the shipment.
 - ✓ Invoice
 - ✓ Packing list
 - ✓ Certificate of conformity
 - ✓ Copy of Supplies Arrival Report (SAR)
- Syringes: Check the lot numbers, expiry dates, and/or manufacturing dates and confirm that they comply with the order requirements.
- Safety boxes: Check a sample of the products to confirm that they comply with the order requirements.
- Vitamin A capsules: Check the batch numbers, and manufacturing and expiry dates, and confirm that they comply with the order requirements.
- Single-use electronic devices: This category includes freeze indicators and 30-day refrigerator temperature loggers. Check the lot numbers, expiry dates, and/or manufacturing dates; and confirm that they comply with the order requirements.
- Refrigerators and freezers: Check that the model numbers comply with the order requirements and that all loose components, such as vaccine baskets and spare parts, have been supplied.
- Cold boxes and vaccine carriers: Check that the model numbers comply with the order requirements and that the correct number and type(s) of water packs have also been supplied.
- Record all required details for each product in the Product Arrival Report (PAR).
- If no problems are identified and the product(s) are accepted, transport them to the correct store or warehouse.
- If problems are identified, stack the unopened shipment on pallets or shelves in a designated area. Clearly mark the shipment "DO NOT USE."
- If problems have been reported, the Store Keeper will carry out follow-up activities, as agreed with supplier. /procuring agent.

Received Shipment Checklist

Date	Purpose	Antigen	Batch No	Manufacture	Received From

Stock placement

If no problems are identified and the product(s) are accepted, stock them in the correct store/location. Any problems/ discrepancy/rejection due to damage/non- conformance with shipping documents should be immediately brought to the attention of the procuring agency through the FDI. DO NOT merge the disputed stock with the active inventory until a final decision is reached.

- Stack the unopened shipment on pallets or shelves in a designated area. Clearly mark the shipment “DO NOT USE.”
- Retain PARs and all correspondence relating to unsatisfactory shipments or procedures for a minimum of 5 years.

Syringes and safety boxes

- After receiving and unpacking the entire stock, physically place all the stock in their respective racks, pallets, and bins.
- Correctly enter the received stock into stock using the Stock Receive form of the vLMIS, as shown below and place them into the designated Dry store Location in the vLMIS as already mentioned above.

Refrigerators, freezers, vaccine carriers, and cold boxes

Record the arrival in the stock control system, including manufacturer's name, model, and serial number. Record the required product details in the national cold chain equipment inventory.

The screenshot shows the 'Cold Chain' search interface in the Vaccine (vLMIS) system. The interface includes a sidebar with navigation options like 'Dashboard', 'Cold Chain', and 'Search Refrigerator'. The main search area is titled 'Search Refrigerator/Freezer/ILR Asset' and contains several input fields: 'Asset Sub Type', 'Source of Supply', 'Working Status', 'Asset ID / Equipment Code', 'Catalogue ID', 'Make', 'Model', 'Serial Number', 'Gross Capacity From', 'Gross Capacity To', 'Working Since From', 'Working Since To', 'Placed At' (with radio buttons for 'Select Warehouse' and 'Unallocated'), 'Office', and 'Warehouse'. A 'Search' button and a 'Reset' button are located at the bottom right of the search area.

Storage

Cold Store

The Store Keeper, under the supervision of the Store Officer/ Assistant Store Officer, is responsible

Stock Receive (Supplier)

The screenshot shows the 'Stock Receive' form. The form is titled 'Fill out this form' and contains several input fields: 'Receipt No.', 'Ref No.', 'Received From (Funding Source)', 'Received Time', 'Purpose', 'Product', 'Used for', 'Manufacturer', 'Batch No.', 'Production Date', 'Expiry Date', 'Unit Price per dose (PKR)', 'Quantity', 'VVM Type', 'VVM Stage', 'Placement Location', and 'Viols'. A green 'Add Stock Receive' button is located at the bottom right of the form.

for the storage of vaccines and supplies at the cold and dry stores at the Warehouse.

- Remove the primary packings of vaccine from cartons and place them in the FR/CRs.
- Store ice packs or coolants received in the FR/CRs.
- Clean soiled or dusty exteriors of cartons before placing those in the stores and/or FR/CRs
- Place the different vaccines in the FR/CRs in an appropriate space between each inner box, block, or tray of vaccine, which will allow the cold air to circulate around the vaccine.
- Store vaccines that have similar packaging in different locations in the cold/refrigerator rooms to avoid confusion and medication errors.

- Place the heat sensitive vaccines in the freezer rooms and other vaccines in the cold rooms.
- Do not place the freeze sensitive vaccines in freezer rooms.
- Vaccines for reconstitution can be placed in both the FR/CRs.
- Place each vaccine carton on the allocated shelf in the FR/CR's lot wise.
- Vaccines stored on pallets or racks should be free from moisture, dirt, insect, or rodent contamination.
- Clean up broken or spoiled product in a timely manner.
- Place proper tags on the vaccine's shelves and racks, including information on vaccine name, manufacturer, purpose, expiry date, and vaccine arrival date.
- Clearly label, with the specific vaccine name, the location of each specific vaccine inside the cold/refrigerator or the storage unit room.
- Inspect that the cold chain equipment is functioning correctly; if any problem is noticed, immediately inform the cold chain mechanical engineer.
- Using the vaccines repacking protocols, repair and repack damaged cartons of vaccines before they are placed in the cold/refrigerator rooms. Rotate vaccine stock once a week; place them in the FR/CRs, based on the expiration date, once a week and every time a new vaccine shipment arrives.
- Set the temperature alarms in the cold/refrigerator rooms; update the temperature logs daily.
- On a daily basis, randomly check the quality of the vaccines, or do a vaccine Shake Test of the suspected batch or lot.
- Disinfect and spray the storage area every third month against insects, rodents, and harmful bacteria, which are threats to the dry supplies and the health of the staff.
- Place and update the vaccine tags located in the appropriate FR/CR any time the status of stocks changes.
- Perform a physical count periodically—monthly, quarterly, and annually—to detect discrepancies.
- Restrict access to storage areas for vaccines to authorized personnel only.
- Record the FR/CR temperature on the logbook or chart twice a day to verify that the storage temperature is within the acceptable temperature ranges of +2°C to +8°C in cold rooms and vaccine refrigerators and -25°C to -15°C in the freezer room and freezers.
- This temperature chart also helps detect temperature alarm conditions that may cause vaccine damage and allows appropriate action to be taken; to assess the performance, over time, for vaccine handling at each link of the cold chain; and to monitor the performance of cold chain equipment.
- A temperature chart for FR/CRs is shown below:

Temperature Chart

Date	AM	°C	Initial	PM	°C	Initial

After receiving stock, both physically and in the vLMIS, locate/place the received stock into the designated CRs/FRs of the vLMIS, as shown below:

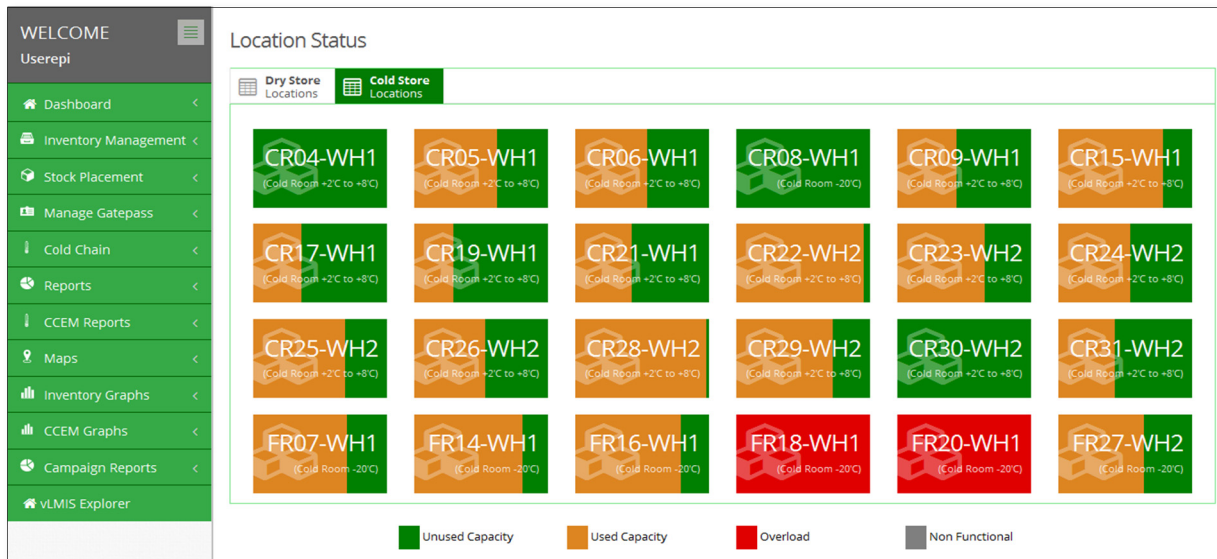

By clicking on the required FR/CR, stock can be placed, as shown below:

WELCOME
User:epi

Stock in Bin - CR06-WH1

Back to Location

25 records per page Print

Product	Batch No.	Expiry Date	Quantity	VVM Stage	Action
Measles-10	004M4131B	31/10/22	12,000	1	Transfer Q
Measles-10	004F4142	31/10/22	90,300	1	Transfer Q
Measles-10	004F4141	31/10/22	90,300	1	Transfer Q
Measles-10	004M4130	31/10/22	900	1	Transfer Q
Measles-10	004M4131A	31/10/22	90,600	1	Transfer Q

Showing 1 to 5 of 5 entries

CR06-WH1 Capacity (In Percentage)

By clicking on transfer button, stock can be transferred from one bin to another, as shown below:

WELCOME
User:epi

Stock in Bin -

Back to Location

25 records per page Print

Transfer Stock from: CR19-WH1

Product	Batch No.	VVM Stage	Available Quantity
Measles-10	004M4131B	1	15900

Location* Select Location Quantity*

Transfer

Product	Batch No.	Expiry Date	Quantity	VVM Stage	Action
Measles-10					Transfer Q
Measles-10 (Campa					Transfer Q
Pneumococcal-2 (P					Transfer Q
Pneumococcal-2 (PCV10)	ASPNA786AA	28/02/18	149,700	1	Transfer Q

Showing 1 to 4 of 4 entries

Storage of Shipment Checklist

A checklist for storing a shipment of vaccine received is shown below:

Storage													
Is Data Logger available & functional?	Are Ice Packs available?	Are Coolant available?	Is Stock received according to prescribed alert?	VVM Stage	VVM Type	Expiry Date	Total Ice Pack Per Carton	Total Primary Boxes Per Secondary Box	Total Vials Per Primary Box	Total Secondary Boxes Per Carton	Total Vials Per Secondary Box	Total Vials Per Carton	Cold Room Number/ Freezer Number in which vaccines are placed

- Place and store the diluents and droppers accompanying the vaccine shipments in the designated bins of the racks in the dry warehouse at room temperature.
- Correctly place and enter the quantities of diluents and droppers on their respective bins in the WMS/vLMIS, as placed in the warehouse.

Dry Store

After receiving stock, both physically and in the vLMIS, locate/place the received stock into the designated bins, pallets, and racks of the vLMIS, as shown below:

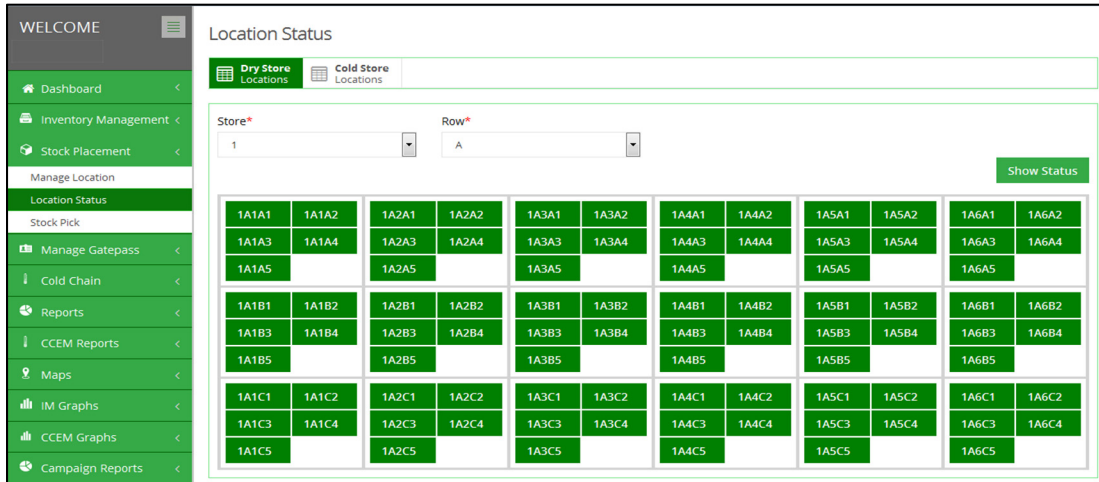

By clicking on the required bin, stock can be placed, as shown below:

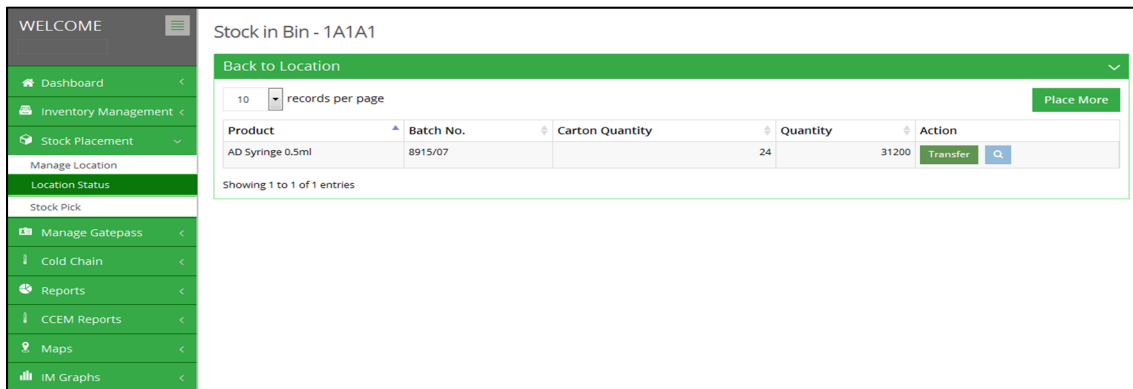

By clicking on transfer button, stock can be transferred from one bin to another, as shown below:

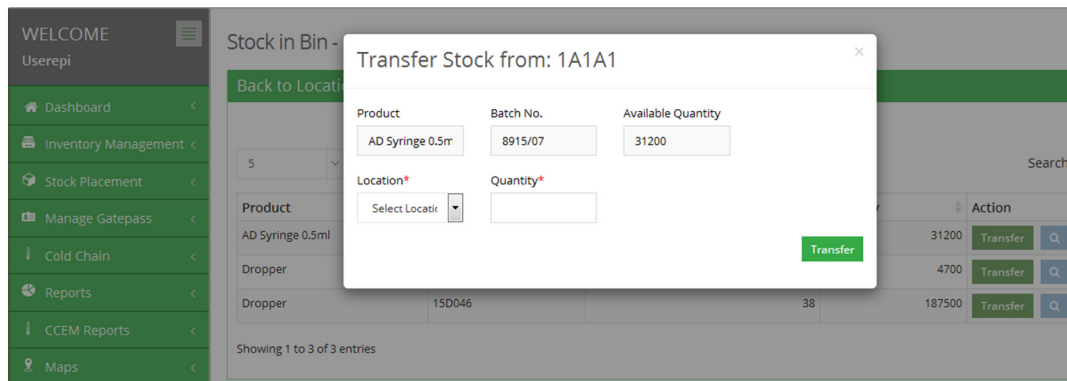

All products are safely stored within the temperature and humidity levels specified for the product type.

- Access to storage areas—including products, packaging materials, and exterior storage areas—must be restricted to authorized personnel only.
- Store diluents, syringes, and other products with a limited shelf life in a separate location so they can easily be located and distributed in FEFO order.
- Store products without an expiry date, such as safety boxes, in a separate location so they can easily be located and distributed in FIFO order.
- Keep expired or damaged products marked for disposal separate from usable stock.
- Using the supplies repacking protocols, repair and repack damaged cartons of dry supplies before they are placed on the racks and pallets in the dry store.
- Rotate stock once a week, based on the expiration date and every time a new shipment arrives.
- Use proper stackers to place pallets in the allocated racks or area; ensure that cartons or pallets are not leaning over the edge of the racks or shelves.
- Maintain pallets, racks, and equipment in good condition to prevent any physical damage to materials or products (e.g., free from nails, wood splinters etc.).
- Keep the dry storage area clear and clean; keep the aisles empty to enable the stacker to operate and to allow people to walk through.
- On a daily basis, randomly check the quality of the dry store supplies.
- Disinfect and spray the storage area every third month against insects, rodents, and harmful bacteria, which are threats to the dry supplies and the health of the staff.
- Use stackers to place pallets on the racks.
- Place and update the diluent bin cards in the dry warehouse any time the status of stocks changes.
- Do a physical count periodically—monthly, quarterly, and annually—to detect discrepancies.
- Place received refrigerators or ice-lined refrigerators (ILRs), vaccine carriers, and cold boxes in the dry warehouse of the FDI Warehouse.
- Ensure that the dry supplies carton is secure and properly packed on all sides.

Issue Procedure

Cold Store

The Store Keeper, under the supervision of the Store Officer/Assistant Store Officer, is responsible for issuing vaccines and supplies to provinces and districts at the Warehouse.

- Acquire the complete signed requisition/demand of vaccines from all provinces, including the public- and private-stakeholders.
- Relevant officials of FDI will review and analyze the vaccine requirements for each stakeholder; to fulfill the requirement against the availability of vaccine stock in the Warehouse.
- Approval sheet, or the release order request, for the requested vaccines will be shared with store officials.
- The approval sheet should contain the essential information, including the quantity requested by the province and district and the current stock status at the Warehouse.
- The approval sheet for the resale of vaccines will include a recommendation to decrease the amount of vaccines based on the actual demand by clients, after a stock sufficiency analyses.
- Vaccines will be issued to all province stakeholders that maintain the minimum/maximum level of vaccine stock at the Warehouse.
- Prepare the vaccine dispatch order sheet/release order that has all the necessary information related to the requested vaccines.
- Generate the electronic vaccine picking list/priority vaccine distribution list from the vLMIS, as shown in the figure below:

Priority Vaccines Distribution

Product	Batch Number	Expiry Date	VVM	Cold room	Summary	Detail
					Quantity (Vials)	Quantity (Doses)
Priority 2						
bOPV (Campaign)	U3P511V	Nov. 2023	Usable	FR18-WH1	15,690	313,800
Total:					15,690	313,800
Priority 3						
bOPV (Campaign)	202202008	Feb. 2024	Usable	FR14-WH1	3,011	72,220
bOPV (Campaign)	202202011	Feb. 2024	Usable	FR14-WH1	1,820	32,400
bOPV (Campaign)	AOP4A710AA	Mar. 2024	Usable	FR36-WH1	19,800	396,000
bOPV (Campaign)	V3F721V	Apr. 2024	Usable	FR20-WH1	11,946	238,920
bOPV (Campaign)	2042322	May. 2024	Usable	FR44-WH2	800	16,000
bOPV (Campaign)	AOP4A720AA	May. 2024	Usable	FR46-WH2	156,942	3,138,840
bOPV (Campaign)	AOP4A721AA	Jun. 2024	Usable	FR34-WH1	22,200	444,000
Total:					216,919	4,338,380
Priority 2						
Measles Rubella-10(MR Routine)	0120W099	Jul. 2023	1	CR41-WH1	161	1,610
Measles Rubella-10(MR Routine)	0120W136	Sep. 2023	1	FR32-WH1	3,350	33,500
Measles Rubella-10(MR Routine)	0120W140	Sep. 2023	1	CR45-WH2	300	3,000
Measles Rubella-10(MR Routine)	0120W179	Oct. 2023	1	FR07-WH1	1,200	12,000
Measles Rubella-10(MR Routine)	0120W171	Oct. 2023	1	CR08-WH1	6,600	66,000

- For vaccines going by air, calculate the number of cartons, vials, diluents, and droppers, as per requisition.

Packing Vaccines

The Store Keeper, under the supervision of the Store Officer/Assistant Store Officer, is responsible for all packing of vaccines and supplies at the Warehouse.

- All the store staff must ensure that they wash their hands thoroughly before handling vaccine cartons and vaccine vials.
- Sort, pick, and pack the different vaccine, as per the packing protocols for each vaccine from the allocated cold/refrigerated rooms.
- Only open the FR/CRs door when necessary; for example, when preparing for vaccine repacking.
- Organize all types of vaccines per the requisition/demand form; segregate them in the different FR/CRs.
- For dispatch of vaccines for far destinations and outreach sessions, follow packing protocols for specific vaccines in order to minimize the risk of damaging the vaccines.
- Before packing, prepare conditioned ice packs (Annex 15) and water coolants, as per the following instructions.

Prepare Ice Packs/Cool Water Packs

- Establish requirements: Calculate the number of ice packs/cool water packs/warm water packs needed for each delivery. Calculate how long it will take to prepare them.
- Prepare ice packs: Place the required number of water packs in a freezer room or freezer that is kept at a temperature between -5°C and -25°C . Leave them until they are fully frozen. If an ice pack fast freezer is used to freeze the ice packs, move the fully ice packs to a conventional freezer or to cold boxes for storage purposes.
- Prepare cool water packs: Place the required number of water packs in a cold room or refrigerator that is kept at a temperature between $+2^{\circ}\text{C}$ and $+8^{\circ}\text{C}$. Leave them to stabilize for a minimum of 12 hours.
 - Cold rooms: DO NOT allow the temperature of the cold room to rise above $+8^{\circ}\text{C}$ during the cooling process. DO NOT allow water packs to touch the vaccines.
 - Refrigerators: Use a dedicated refrigerator. DO NOT cool water packs in a refrigerator that contains vaccine.

Packing vaccines that are not damaged by freezing

The following vaccines are NOT damaged by freezing. They can safely be packed and transported using fully ice packs at all times of the year.

- ✓ OPV—monovalent, bivalent, and trivalent
- ✓ BCG
- ✓ Measles and rubella

The following points must be ensured before packing these vaccines:

- Use the correct size and number of ice pack for the chosen cold box. Line the cold box exactly as described on the instructions on the inside of the cold box lid.
- Pack the vaccine cartons in the cold box with the vial caps facing up.

- Use newspaper or other loose packing to ensure that the load cannot shift during transport.
- Place a freeze indicator device in the box on top of the contents.
- Place a packing list in the box on top of the contents.
- Label the box with the final destination.
- Close the lid and engage the catch.
- Keep the cold box in the packing room, or in a covered holding area, until all other boxes in the consignment have been packed.
- Keep the cold box away from direct sunlight during transport.

Packing freeze-sensitive vaccines using conditioned ice packs

The following vaccines ARE damaged by freezing and must always be packed as described below:

- ✓ hepatitis B (Hep B)
- ✓ pentavalent (DTP-Hep B-Hib)
- ✓ pneumococcal vaccine (PCV-10)
- ✓ tetanus toxoid vaccine (TT)

The following points must be ensured before packing these vaccines:

- Condition the required number of ice packs as described in Annex 14 for Conditioning frozen ice packs. (Annex 14.)
- Use the correct size and number of fully conditioned ice packs for the chosen cold box. Line the cold box exactly as described in the instructions on the inside of the cold box lid.
- Pack the vaccine cartons in the cold box with the vial caps facing up.
- Use newspaper or other loose packing to ensure that the load cannot shift during transport.
- Place a packing list and freeze indicator device in the box on top of the contents.
- Label the box with the final destination.
- Close the lid and engage the catch.
- Keep the cold box in the packing room, or in a covered holding area, until all other boxes in the consignment have been packed.
- Keep the cold box away from direct sunlight during transport.

Packing freeze-sensitive vaccines using cool water packs

The following vaccines ARE sensitive to freezing and must always be packed as described below:

- ✓ hepatitis B (Hep B)
- ✓ pentavalent (DTP-Hep B-Hib)
- ✓ pneumococcal vaccine (PCV-10)
- ✓ tetanus toxoid vaccine (TT)

The following points must be ensured before packing these vaccines:

- Use the correct size and number of cool water packs (+2°C to +8°C) for the chosen cold box. Line the cold box exactly as described in the instructions on the inside of the cold box lid.
- Pack the vaccine cartons in the cold box with the vial caps facing up.
- Use newspaper or other loose packing to ensure that the load cannot shift during transport.
- Place a packing list and freeze indicator device in the box on top of the contents.
- Label the box with the final destination.
- Close the lid and engage the catch.
- Keep the cold box in the packing room, or in a covered holding area, until all other boxes in the consignment have been packed.
- Keep the cold box away from direct sunlight during transport.

Packing diluents

- Pack inner diluent cartons in sturdy cardboard boxes or plastic crates.
- Use newspaper or other loose packing to ensure that the load cannot shift during transport.
- Place a packing list in the box on top of the contents.
- Label the carton with the final destination.
- Keep diluent cartons away from direct sunlight during transport.
- Keep the cold box away from direct sunlight during transport. Repack all the damaged/broken cartons of dry supplies before loading onto the truck.
- Ensure that the cartons are sealed with plastic tape for protection and to ensure the cartons do not break at the edges.

Note: If diluents are frozen, the glass ampoule is likely to break, so they must never be exposed to temperatures below 0°C.

- After packing all the vaccines into cartons, according to set protocols, post tags on each repacked carton that includes the following information, signed by the Store Keeper and Store Officer:
 - ✓ Name of vaccine
 - ✓ Manufacturer
 - ✓ Consignee location to be dispatched
 - ✓ Expiry date of vaccine
 - ✓ Quantity in vials
 - ✓ Number of ice packs
- Provide a packing list/shipment report that includes the following information for all repacked vaccine cartons, duly signed by the Store Keeper and Store Officer.
- Ensure that the provided repacking list is used to repack the correct item, and the correct quantity, for the correct stakeholder, and for the correct district.
- Scan the vaccines that have barcodes; update the WMS/vLMIS or stock register.

- For vaccines transported by refrigerated trucks, arrange the truck for the sorted dispatch; load and place the insulated containers of vaccines onto the refrigerated truck.
- Physically count the loaded vaccines in the presence of the truck driver or relevant person who removed the vaccines from the Warehouse.
- The WMS/vLMIS operator generates the electronic issue and dispatch voucher for dispatching the vaccine consignment, which includes the following information, as shown in the figure below:
 - ✓ Reference number of demand letter/requisition
 - ✓ Issue reference
 - ✓ Date/time of issuance
 - ✓ Purpose
 - ✓ Office
 - ✓ Product
 - ✓ Batch number
 - ✓ VVM stage
 - ✓ Quantity in vials
 - ✓ Stock issue voucher in the vLMIS

Stock Issue/Dispatch

Please email support@lmis.gov.pk OR contact 051-3350534 Ext. 155 in case of any problem/question.

Fill out this form

Issue No. <input type="text"/>	Date <input type="text" value="20/01/2023 02:27 PM"/>	Issue Reference <input type="text"/>	Purpose * <input type="text" value="Select"/>
Office * <input type="text" value="Select"/>			
Product * <input type="text" value="Select"/>	Used for <input type="text"/>	Manufacturer Batch Quantity Priority* <input type="text"/>	Location VVM Stage Quantity <input type="text" value="NA"/>
Quantity * <input type="text"/>	Total available batch quantity <input type="text"/>	Expiry Date <input type="text"/>	Dispatch By <input type="text"/>
Unit			

Add Issue

- Prepare and print three copies of the Stock Issue/Dispatch vouchers from the WMS/vLMIS and get the approval of the relevant authority of the Warehouse.
- The vLMIS operator will issue a gate pass by vLMIS, which has the information for the dispatched quantity to the consignee.
- Give one copy of the issue voucher, signed by the Store Keeper, Store Officer, and receiver, including the gate pass, to the transporter; one copy for the receiver/consignee; and a third copy will be kept at Warehouse as a confirmation that the vaccines/supplies were delivered to and received by the consignee.
- Follow up with the freight forwarders/transporter for the timely deliveries of vaccines to the consignee.

The figure below summarizes the process of issuance and dispatch:

Figure 48. Flow Chart of Process for Issuing Vaccines

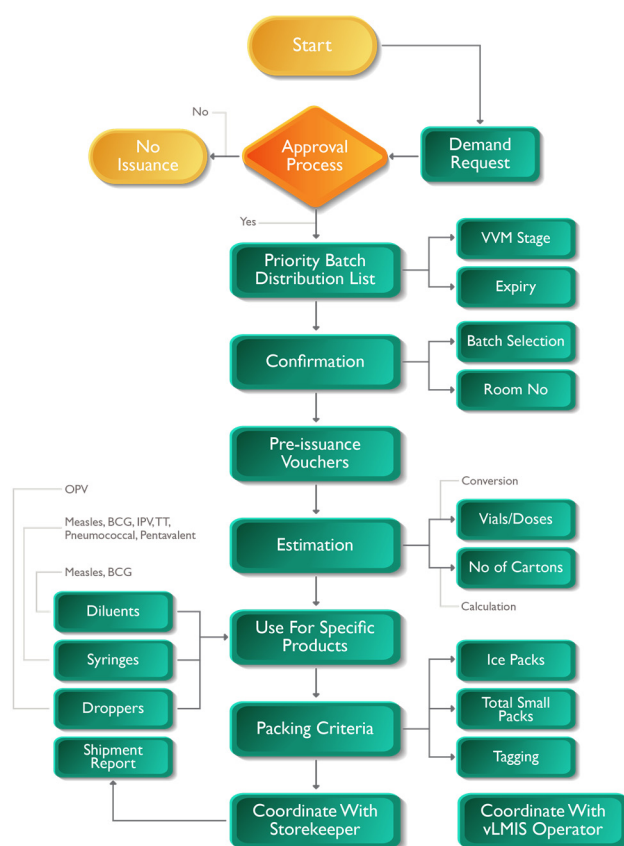

Dry Store

The Store Keeper, under the supervision of the Store Officer/Assistant Store Officer, is responsible for issuing vaccines and supplies to the provinces and districts at the Warehouse.

- Acquire the complete signed requisition/demand of compulsory dry supplies from all provinces, including the public and private stakeholders.
- Review and analyze the vaccine supplies requirements for each stakeholder; to fulfill the requirement, check the availability of the dry store stock in the Warehouse.
- Prepare the approval sheet, or the release order request, for the requested supplies for approval from the relevant Warehouse authority.
- The approval sheet should contain the essential information, including the quantity requested by the province and district and the current stock status at the Warehouse.
- The approval sheet for the resale of supplies will include a recommendation to decrease the number of ancillary items of vaccines by the actual demand by clients, upon stock sufficiency analyses.
- Supplies will be issued to all province stakeholders that maintain the minimum/maximum level of vaccine stock at the Warehouse.

- Prepare the supplies dispatch order sheet/release order that has all the necessary information related to the requested supplies.
- Follow the criteria of FEFO for dispatch of batches.
- Sort, pick, and pack the different supplies as per the packing protocols of each dry store item, from the allocated racks, pallet location.
- Arrange the supplies for loading.
- Arrange the truck for the sorted dispatch; load the consignment of supplies.
- Physically count the loaded supplies in the presence of the truck driver or relevant person who removed the supplies from the Warehouse.
- The WMS/vLMIS operator generates the electronic issue and dispatch voucher for dispatching the consignment, which includes the following information, as shown in figure below:
 - ✓ Reference number of demand letter/requisition
 - ✓ Issue reference
 - ✓ Date/time of issuance
 - ✓ Purpose
 - ✓ Office
 - ✓ Product
 - ✓ Batch number
 - ✓ Quantity in vials.

- Prepare and print three copies of the Issue/Dispatch vouchers from the WMS/vLMIS and get the approval of the relevant authority of the Warehouse.
- The vLMIS operator will issue a gate pass by vLMIS, which has the information of the dispatched quantity to the consignee.

Give one copy of the Issue/Dispatch voucher signed by the Store Keeper, Store Officer, and receiver, and including the Gate Pass to the transporter; one copy for the receiver/consignee; and a

third copy will be kept at the Warehouse as a confirmation that the supplies were delivered to and received by the consignee.

- Follow up with the freight forwarders/transporter for the timely delivery of supplies to the consignee.

Disposal

Unusable Vaccine

The Store Keeper, under the supervision of the Store Officer/Assistant Store Officer, is responsible for the maintenance and disposal of unusable vaccines and supplies.

- If, for any reason, vaccines are identified as unusable (expired, physically damaged from heat exposure and freezing etc.), the relevant Warehouse or store authority should immediately stop distributing the unusable vaccine stock.
- Immediately separate the identified vaccine lot, batch, or any quantity identified in the Warehouse as unusable stock.
- Store the container having unusable vaccines in a cold room or vaccine refrigerator until permission is given to take it out of the cold chain.
- Clearly mark the assigned storage area as “EXPIRED VACCINES FOR DISPOSAL-DO NOT USE,” in the case of expired vaccines.
- Clearly mark as “DAMAGED VACCINES FOR DISPOSAL-DO NOT USE” in case of physically damaged vaccines, due to heat exposure (VVM color change) and freezing, so that items placed here cannot be confused with usable stock.
- If diluents also need to be removed from stock, place them in a container clearly marked “EXPIRED DILUENTS FOR DISPOSAL—DO NOT USE.”
- Record and update the vLMIS regarding the expired vaccines or diluents. Prepare a loss and adjustment report.
- Immediately notify the relevant Warehouse or store office authorities through the proper procedures and policies of the Warehouse.
- By providing a detailed description of the unusable vaccine, the relevant Warehouse higher authority can initiate further actions and can form a committee to identify why the vaccine stock was found unusable, and arrange for its safe disposal.
- The committee will advise the Warehouse relevant authority how to safely dispose of the unusable vaccines and diluents.
- The committee may finally decide to dispose of or use the identified vaccine stock, based on laboratory tests and other findings from the vaccine stock inspection.
- Hazardous/infectious vaccine waste must be disinfected and buried, incinerated, or disposed of by following specific and established procedures for disposing of vaccines.
- To ensure that expiries or damages do not occur again, the committee will provide a detailed report on the expiries or damaged vaccines stock, and the action and corrections that took place.

DAMAGED ANCILLARY ITEMS

- If, for any reason, ancillary items are identified as unusable (expired, damaged, etc.), the relevant Warehouse or store authority should immediately stop distribution of the unusable stock.
- Immediately separate the identified lot, batch, or any quantity identified in the Warehouse as unusable stock.
- Assign a separate well-ventilated room for these products. Clearly mark the assigned storage “PRODUCTS FOR DISPOSAL—DO NOT USE” so that items placed here cannot be confused with usable stock.
- Immediately notify the relevant Warehouse or store authority through the proper procedures and policies of the Warehouse.
- By providing a detailed description of the unusable ancillary items, the relevant Warehouse higher authority can initiate further actions and can form a committee to identify why the stock was damaged or expired and arrange for its safe disposal.
- The committee will advise the Warehouse relevant authority how to safely dispose of the unusable supplies.
- The committee may finally decide to dispose of the unusable stock either through incineration or by landfill. Other methods may include inertization, chemical treatment, or by using sharps pits.
- To ensure that expiries or damages do not occur again, the committee will provide a detailed report on the expiries or damaged vaccines stock, and the action and corrections that took place.

Appendix – G: Warehouse Monitoring and Evaluation Checklist

Warehousing and Inventory Management Checklist

Inspection Date: _____

Next Inspection Date: _____

Name: _____

Designation: _____

*NS= Not Sure **NA= Not Applicable

#	Warehousing and Inventory Management	Responsible Person Name Designation		Evidence	YES	NO	NS*	NA*	Conclusion /Remarks
1	Designated staff receives the stock and properly reviews all shipment documents.								
2	For received stock, the physical count is reconciled with the shipment documents.								
3	Received stock of vaccines and data loggers is checked.								
4	Received stock is physically checked for VVM, expiry, quantity, quality, and packing.								
5	For received stock, damages, losses, errors, and discrepancies are reported.								
6	For received stock, shipment checklist is properly filled out and completed.								
7	All the details for the received stock is recorded in VAR and SAR (supplies arrival report).								
8	For received stock, the shipment with barcodes on the cartons is scanned; updates are made in the WMS/vLMIS.								

#	Warehousing and Inventory Management	Responsible Person Name Designation	Evidence	YES	NO	NS*	NA*	Conclusion /Remarks
9	For received stock, racks and items are named accordingly and reported in the WMS/vLMIS.							
10	Stock received is shown in the WMS/vLMIS by location, racks, and pallets.							
11	Designated staff can report in the WMS/vLMIS the received quantity/vials, by vaccine, lot, location, and rack in the warehouse/cold room.							
12	Stock received is shown in the correct quantity and product name in the bin cards and stock cards.							
13	Designated staff receiving the stock understands and follow the receiving procedures and systems.							
14	Designated staff is properly trained to receive stock and report.							
15	Designated staff knows the loss and damages policy for reporting.							
16	Designated staff has all required stationery and equipment to do their work efficiently.							
17	Designated staff has the proper manuals and warehouse operating forms.							
18	Staff knows about and can use the various warehouse manuals and stock reporting forms.							
19	Vaccines and supplies requisitions are received on time for further action.							
20	Vaccines and supplies are dispatched, based on the requested quantity/vials.							
21	Vaccines and supplies are dispatched using the FEFO system.							

#	Warehousing and Inventory Management	Responsible Person Name Designation	Evidence	YES	NO	NS*	NA*	Conclusion /Remarks
22	After vaccines and supplies are dispatched, a physical count is reconciled with the dispatched requisition.							
23	Dispatched vaccines and supplies are properly scanned and reported in the WMS/vLMIS.							
24	Designated staff can report in the WMS/vLMIS the dispatched vaccines and supplies by stakeholder, district, and province.							
25	Dispatched vaccines and supplies have proper stock issuing vouchers and gate passes.							
26	Vaccines and supplies dispatched are updated in the bin cards and stock cards.							
27	Designated staff can report daily and print vaccines and supplies stock sufficiency reports through the WMS/vLMIS.							
28	All vaccines and supplies received and dispatched are correctly reported in the WMS/vLMIS.							
29	Designated staff regularly report and update the WMS/vLMIS.							
30	Designated staff manages vaccines and supplies in the WMS/vLMIS using the FEFO system.							
31	Designated staff manage inventory by location, rack, and pallet or shelves in the cold room or dry store.							
32	Designated staff can identify the stock location, rack, and pallet for each vaccine or supply in the warehouse in the WMS/vLMIS.							

#	Warehousing and Inventory Management	Responsible Person Name Designation		Evidence	YES	NO	NS*	NA*	Conclusion /Remarks
33	All warehouse operating equipment—stackers, forklifts, computers, etc.—are in working condition and are well maintained.								
34	All the WMS/vLMIS equipment is running smoothly, and is kept and maintained in good condition.								
35	All features of WMS/vLMIS are working appropriately and are error free.								
36	Vaccine stock sufficiency reports are signed by the relevant FDI/EPI Warehouse authority and properly maintained in files.								
37	Designated staff has taken precautionary measures to safeguard stock from rodents, insects, loss, and damages.								

Warehouse Safety and Security Checklist

Inspection Date: _____

Next Inspection Date: _____

Name: _____

Designation: _____

*NS= Not Sure **NA= Not Applicable

#	Warehouse Safety and Security	Responsible Person Name Designation		Evidence	YES	NO	NS*	NA**	Conclusion /Remarks
1	Are all warehouse exits clearly marked and clear of obstructions (barriers)?								
2	Are the warehouse aisles clear of storage?								
3	Are all pallets, racks, and shelving in good condition and undamaged?								
4	Are all materials stacked properly and are not leaning?								
5	Are guardrails (sign of dangerous area) present in areas of overhead storage above offices or platform?								
6	Are material handling equipment in place and available?								
7	Do stacker operators get proper training to operate the stacker or forklift?								
8	Are horns used during backing, blind corners, and other potentially dangerous situations?								
9	Do forklifts travel at a safe speed?								
10	Do operators wear seat belts?								
11	Are keys removed and forks lowered when the forklifts are parked?								
12	Are stackers charged in a place free from combustibles and with adequate ventilation?								

#	Warehouse Safety and Security	Responsible Person Name Designation		Evidence	YES	NO	NS*	NA**	Conclusion /Remarks
13	Are fire extinguishers placed in each area of the warehouse and are they accessible?								
14	Are fire extinguishers checked monthly?								
15	Are flammable and combustible materials stored in flammable-proof storage cabinets?								
16	Is adequate equipment available to minimize employees lifting heavy or awkward objects?								
17	Are electrical outlets, junction boxes, and other electrical components properly covered?								
18	Are extension cords in good repair, properly grounded, etc.?								
19	Are panel box doors labeled and closed?								
20	Are individually keyed locks and tags available for lock and lockout tags of equipment?								
21	Are equipment-specific lock and lockout tag procedures available?								
22	Is PPE available and in good condition?								
23	Do employees know when to wear PPE?								
24	Does designated staff randomly check the warehouse fire-fighting system?								
25	Does designated staff maintain the warehouse building in good condition?								
26	Does designated staff monitor the night and day security guards to ensure warehouse security?								

#	Warehouse Safety and Security	Responsible Person Name Designation		Evidence	YES	NO	NS*	NA**	Conclusion /Remarks
27	Does designated staff properly lock the warehouse main doors and main exit gate?								
28	Does the gatekeeper/guard register visitor information, as required?								
29	Do the gatekeeper/ guard check incoming and outgoing stock documentation and registering information?								

Cold Chain Maintenance and Monitoring Checklist

Inspection Date: _____

Next Inspection Date: _____

Name: _____

Designation: _____

*NS= Not Sur, **NA= Not Applicable

#	Cold Chain Maintenance and Monitoring	Responsible Person Name Designation	Evidence	YES	NO	NS*	NA**	Conclusion /Remarks
1	Does the FDI/EPI store have designated staff in charge of vaccines and biologics?							
2	Is the designated staff properly trained on vaccine and biologics cold chain maintenance protocols?							
3	Do FDIEPI stores have a designated backup staff to check the vaccine and biologics cold chain maintenance protocols?							
4	Is all staff properly trained on vaccines and biologics storage and handling protocols?							
5	Does the FDIEPI store have a purpose-built (lab style) refrigerator? Domestic (freezer compartment with a separate external door)?							
6	Does the designated staff record the temperature level of the freezer/refrigerator cold room in the temperature log, at least twice a day?							
7	Does the designated staff take corrective action when the temperature is out of range?							
8	Does the designated staff ensure, daily, that the refrigerator/refrigerated cold room temperature is within the range of 2–8°C for positive cold rooms?							
9	Does the designated staff ensure, daily, the freezer/freezer cold room temperature is -15°C or colder for negative cold rooms?							

#	Cold Chain Maintenance and Monitoring	Responsible Person Name Designation		Evidence	YES	NO	NS*	NA**	Conclusion /Remarks
10	Does the designated staff know who to call if the refrigerator/refrigerated cool room temperature is out of range?								
11	Does the FDI/EPI store have “DO NOT UNPLUG” and “Warning” notices next to the refrigerator’s electrical outlet and at the circuit breakers?								
12	Does the designated staff follow standard cold chain inventory management protocols?								
13	Does the designated staff store the vaccines and biologics in the middle shelves of the refrigerator/ refrigerated cold room shelves?								
14	Is the instruction available on the refrigerator/ refrigerated/freezer cold room door showing how the different vaccines refrigerator/refrigerated/freezer cold rooms should be organized?								
15	Does the designated staff understands the instructions on the refrigerator/ refrigerated/freezer cold room door that shows how the vaccine refrigerator should be organized?								
16	Every time after the refrigerator/refrigerated/freezer cold room door is opened, does the designated staff ensure that it is properly closed and locked?								
17	Does the designated staff check the stock expiration date and use the stock that will expire first?								
18	Does the designated staff rotate vaccines stock (newest stock is placed behind stock with the shortest expiry date)?								

#	Cold Chain Maintenance and Monitoring	Responsible Person Name Designation		Evidence	YES	NO	NS*	NA**	Conclusion /Remarks
19	Does the designated staff understand and apply the protocols/guidelines for storing and handling vaccines and biologics?								
20	Is the capacity of the cold chain equipment (ice-lined refrigerators, ice boxes) sufficient for vaccine storage?								
21	Is a process in place to manage times when the temperature exceeds the maximum or minimum from the recommended level of temperature?								
22	Does the FDI/EPI store have technical assistance for vaccine when the temperature exceeds minimum or maximum stability or related issues?								
23	Does the designated staff follow the standard procedure practices for waste disposal?								
24	Is vaccine transported in a temperature-monitored vehicle?								
25	Are vaccine packs in the insulated container (box) and is ice packed correctly and placed in the insulated container when dispatching vaccine for distribution?								
26	Does the designated staff know the appropriate protocols for vaccine transportation; do they follow set protocols while transporting vaccines?								
27	Are diluent, syringes, and safety boxes received in cardboard cartons?								
28	Are all diluents, syringes, and safety boxes properly stacked on pre-assigned pallet bays?								
29	Are diluent, syringes, and safety boxes stacked on allocated pallet bays by batch number and expiry date?								
30	Are the WHO pre-qualified electronic calibrated								

#	Cold Chain Maintenance and Monitoring	Responsible Person Name Designation		Evidence	YES	NO	NS*	NA**	Conclusion /Remarks
	temperatures monitoring devices in place in the refrigerator/refrigerated/freezer cold rooms?								
31	Do the temperature control devices have an alarm system; is it in working condition?								
32	Is the temperature low alarm set for vaccine or diluent when it is exposed to -5.5°C or below?								
33	Is the temperature high alarm set for vaccine or diluent if it is exposed to +8°C or above?								
34	Does the concerned designated staff at the FDI/EPI store know the shake test protocols for the pentavalent, pneumococcal, and tetanus/typhoid vaccine?								
35	Does the designated staff keep all cold/freezer rooms keys in a safe place?								
36	Does the designated staff check the cold chain technical aspects daily, weekly, and monthly?								
37	Does staff wear the protecting cloth for excessive cold when they enter the cold/freezer rooms?								
38	Does the designated staff use the required schedule to check the VVM?								

Transport Checklist

Inspection Date: _____

Next Inspection Date: _____

Name: _____

Designation: _____

*NS= Not Sure **NA= Not Applicable

#	Transport	Responsible Person Name Designation	Evidence	YES	NO	NS*	NA**	Conclusion /Remarks
1	Does the driver check the oil level daily?							
2	Does the driver check the hoses monthly?							
3	Does the driver check all the belts monthly?							
4	Does the driver check the tire pressure daily?							
5	Does the driver check coolant/antifreeze monthly?							
6	Does the driver change the air filter, based on the recommended mileage?							
7	Does the driver change the engine oil, based on the recommended mileage?							
8	Does the driver change the oil filter, based on the recommended mileage?							
9	Does the driver check the brake fluid every 3 months?							
10	Does the driver check the battery water level weekly?							
11	Does the driver check the steering fluid every 3 months?							
12	Does the driver check the headlights daily?							
13	Does the driver have a spare tire in the vehicle?							
14	Does the driver know the basic government traffic rules and regulations?							

#	Transport	Responsible Person Name Designation		Evidence	YES	NO	NS*	NA**	Conclusion /Remarks
15	Does the driver carry the required documents, license, vehicle registration book, etc.?								
16	Are the vehicles available and in working condition when needed?								
17	Does the driver maintain the vehicle logbook properly?								
18	Does the driver maintain the vehicle fuel book properly?								
19	Is vaccine transported in a temperature-monitored vehicle?								
20	Does your practice have a dedicated and validated cool box for transporting the vaccines to the field or in the store?								
21	To ensure the required temperature is maintained throughout the transport, does the designated staff in the FDI/EPI store use a temperature monitoring device to check the cold chain for the vehicles?								
22	Does the driver know the required temperature that must be maintained in the cold chain truck while transporting the vaccines and diluents?								
23	Does the driver know the vaccine and diluent transportation protocols?								
24	Does the driver know how to respond if the refrigeration unit fails?								
25	Does the driver know the backup plan if the refrigeration unit fails?								



Appendix – H: How to Use the ILR



Icelined Refrigerator استعمال کرنے کا طریقہ



3

جگہ

یہ ضروری ہے کہ فریج کو ہوا دار کمرے میں رکھا جائے، اور سورج کی براہ راست روشنی اور تیز و غیر تیز سے دور رکھا جائے۔

یہ بھی خیال رکھیں کہ فریج یا جس چیز فریج رکھا گیا ہو اس کا لیول لیگل درست ہو۔ نہ پیر رہنمائی کے لئے خاک نمبر 3 ملاحظہ فرمائیں۔

فریج کی چٹائی سطح اور فرش کے مابین کم از کم 30mm کی جگہ موجود ہونا ضروری ہے۔

اہم اس بات کا خیال رکھیں کہ پینٹیشن کرل کے ساتھ کوئی رکاوٹ نہ ہو۔



6

فریج میں اشیاء رکھنے کا طریقہ

ویکسین رکھنا

جب ویکسین کے خانے میں درجہ حرارت مسلسل ایک سطح پر آجائے یعنی کہ درجہ حرارت مستقل طور پر $+2^{\circ}\text{C}$ اور $+8^{\circ}\text{C}$ کے درمیان رہنے لگے اور کچھ لیر خود بخود پھلنے اور بند ہونے لگے تو اس موقع پر فریج میں ویکسین رکھی جاسکتی ہیں۔ تمام ویکسین خاک نمبر 6 میں دیکھے گئے طریقے کے مطابق منسور کریں۔

آکس پیک کا لوڈ اور فریج کرنا

خاکہ میں دی گئی شکل کے مطابق آکس پیک کو رکھنا چاہیے، یعنی اس کی سطح اندرونی لانگک سے متصل ہو۔ ویکسین والے خانے کے قریب کھڑی کا ڈبھی تہ کے ساتھ ہی ترتیب سے رکھیں۔ اور اس بات کا خاص خیال رکھیں کہ آکس پیک سے متصل فریج میں پینل سے چند آکس پیک کھڑی کے ذریعے رکھے جانے چاہیں۔ 24 گھنٹوں میں آکس پیک ٹھنڈ ہونے کی تعداد کو انحصار اس بات پر ہے کہ اس کے درجہ حرارت کتنا ہے۔ اگر درجہ حرارت $+32^{\circ}\text{C}$ ہو تو 24 گھنٹوں میں 3 آکس پیک ٹھنڈ کئے جاسکتے ہیں۔



7

کھڑی کے ذریعے فریج میں آکس پیک رکھنے کی جگہ۔
آکس پیک کی فریج پیک کی جگہ، اندرونی لانگک کے ساتھ منسلک ہے۔
اگر کئی جگہ جاسے تو آکس پیک فریج کرنے کی کوشش نہ کریں۔
ویکسین منسور کرنے کے لئے خانہ۔

تربیل شوٹنگ

خرابی	تعمیر وجہ	تعمیر کرنے کا طریقہ
کچھ لیر ٹھنڈ چل رہا اور تہی آکس پیک ٹھنڈ سے ہیں	تھوڑا وقفہ رکھیں کچھ لیر ٹھنڈ اوقات تیار ہونے میں تھوڑا وقت لیتا ہے۔	<ul style="list-style-type: none"> اگر تھوڑا وقفہ کرنے کے بعد کچھ لیر ٹھنڈ نہیں ہو رہا تو درجہ ذیل کریں: • یا بات چینی بنا کئیں کئی کی تاریخ گئی ہے۔ • لٹو چیک کریں اور اگر ضرورت ہو تو لٹو ڈال لیں۔ • اگر دونوں درست ہیں تو ٹیکنیکل سپورٹرز سے رابطہ کریں۔
کچھ لیر تو چل رہا ہے لیکن درجہ حرارت بہت زیادہ ہے	<ul style="list-style-type: none"> • یہ ویکسین رکھیں یعنی لٹو ڈال لیں کہ نہیں ہے۔ • دیکھیں کچھ طریقے سے بند ہو۔ • جس کمرہ یا جگہ میں فریج رکھا گیا ہو وہاں بہت زیادہ گرمی تو نہیں۔ 	<ul style="list-style-type: none"> • ہوا کی باڈارک سے کڑی کھینچی جائیں۔ • دیکھیں کچھ طریقے سے بند کریں۔ • اگر فریج پر براہ راست دھوپ میں ہے تو فوراً اس کا انتظام کریں اور اس امر کو یقینی بنائیں کہ کمرہ کچھ گرم نہ ہو۔
درجہ حرارت طاہر نشین ہو رہا	<ul style="list-style-type: none"> • فریج میں تھوڑا سا پانی ہے۔ • پینل تو اتنی ہے پھلنے والے پینل کے لئے مناسب روشنی نا پھیر ہو۔ 	<ul style="list-style-type: none"> • فریج میں تھوڑا سا پانی ہے۔ • لٹو کا مناسب انتظام کریں۔

درجہ حرارت کا کنٹرول

کسی بھی ایسے اور درست تھرموسٹیٹ کے ساتھ روزانہ فریج کے اندرونی درجہ حرارت کا مانیٹورنگ ایک دفعہ ضرور کریں۔ وولڈ ہائیڈرو آکسجن نیشن کے قواعد و ضوابط کے مطابق بھی باقاعدہ اندرونی درجہ حرارت کو چیک کرنا ضروری ہے۔

فریج کا ٹھنڈا ہونا

فریج میں ویکسین رکھنے سے پہلے اس بات کو یقینی بنائیں کہ آکس پیک کے چاروں طرف برف جم چکی ہو۔ اس عمل کو یقینی بنانے کے لئے درج ذیل اقدامات کریں:

1. اوپر والی ڈگری میں ایک تھرموسٹیٹ رکھیں۔
 2. پہلے اوپر اور پھر نیچے والی ڈگری کا درجہ حرارت چیک کریں۔ (درجہ حرارت $+2^{\circ}\text{C}$ اور $+8^{\circ}\text{C}$ کے درمیان ہونا چاہیے)
- ویکسین والے خانے میں اسی درجہ حرارت کو چیک کرتے رہیں جو کہ $+2^{\circ}\text{C}$ اور $+8^{\circ}\text{C}$ کے درمیان میں رہے۔

دیکھنے کے اطراف سیٹنگ اسٹریپ کو باقاعدگی سے صاف کرتے رہیں۔
مٹائی کے لئے ہمیشہ صاف ستھرا پانی استعمال کریں۔ سیٹنگ اسٹریپ کو صاف کرنے کے بعد یہ ضرور چیک کریں کہ سیٹنگ اسٹریپ کی گرپ مشروط ہے۔

اگر فریج رکھو سے لئے استعمال میں نہیں رکھنا چاہتے تو کھلی کی چابی منقطع رکھیں۔ اور فریج کو باہر کھلی اور صاف ستھرا ہونا چاہیے۔ اور دیکھنے کھلا چھوڑ دیں تاکہ وہ آجائے اور فریج کے اندر کئی بلو پیوٹ ہو۔

استعمال کا طریقہ

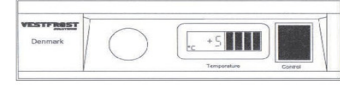

خاک نمبر 6

الیکٹرانک تھرموسٹیٹ

فریج میں ویکسین کے خانے میں ایک الیکٹرانک تھرموسٹیٹ نصب ہے جو کہ درجہ حرارت کنٹرول رکھتا ہے۔ تھرموسٹیٹ کا درجہ حرارت لیڈر میں ہی سیٹ کر دیا جاتا ہے، لہذا اگر کوئی اس کو بھرنے کا چاہتے ہیں۔

شروع کرنے کا طریقہ

فریج کے ساتھ مہیا کیا گیا ہو لیکن تھرموسٹیٹ استعمال کریں اور پارٹیٹل کو پارٹیٹل میں لگائیں۔ ہر رنگ کے لیڈ فوراً رد ہونا چاہئے۔ (خاک نمبر 6) تاکہ یہ بات یقینی ہو کہ فریج ٹھنڈ طریقے سے آن ہو گیا ہے۔ کچھ لیر کے کام شروع کرنے سے 20 سیکنڈ پہلے لٹو ڈال کر تھرموسٹیٹ خود بخود ڈیٹیمٹ کرتا ہے۔

روزانہ کی دیکھ بھال

اس بات کا خیال رکھیں کہ ویکسین کے خانے کا درجہ حرارت تھرموسٹیٹ پر روزانہ چیک ہو۔ اور اس بات کا بھی خیال رکھیں کہ ویکسین ہم تو نہیں رہیں۔

باہر نکلنے کی دیکھ بھال

ہر ماہ روزانہ دیکھ بھال کریں تاکہ اس طرف نصب شدہ گرل کو صاف کریں۔

سالانہ دیکھ بھال

کھلی کے کنکشن اور دیگر آلات کا سالانہ چیک کرنا اور صاف کرنا ضروری ہے یا پھر جب بھی آپ اس امر کی ضرورت محسوس کرتے ہوں۔

مٹائی

مٹائی سے پہلے کھلی کی چابی منقطع کر دیں۔ مٹائی کے لئے بہتر ہے کہ جس پانی سے آپ دھو رہے ہوں اس کا پانی کا درجہ حرارت تقریباً 85°C ہو۔ اس پانی میں تھوڑا سا خوشبو کے پھیر بڑھتے ہی ملائیں۔ خیال رکھیں کہ بہت زور سے مٹائی نہ کی جائے۔ مٹائی کے لئے نرم پیر استعمال کریں۔ اور اس کے بعد صاف پانی سے دھو کر اچھی طرح خشک کریں۔ اس بات کا خیال رکھیں کہ پانی کنٹرول میں نہ جانے پائے۔



USAID
FROM THE AMERICAN PEOPLE

USAID GLOBAL HEALTH SUPPLY CHAIN PROGRAM
Procurement and Supply Management

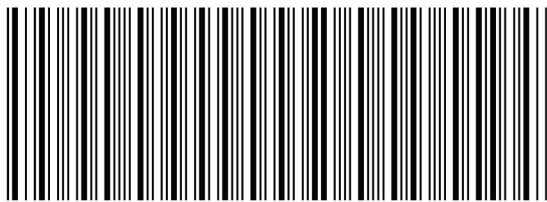

978-627-7638-40-5